



White Paper

KNX for Metering, Displaying and Energy Management

1 Introduction

By means of the mandate M441 as issued in 2009, the European Commission has given the European Standardisation Organisations (ESOs) the task to come forward with standards for interoperable smart meters.

The above mandate was issued in the light of soaring energy prices shortly before the financial crisis of 2008 and the climate change debate. As a consequence, initiatives are taken to:

- Increase the use of renewable energies (solar, wind, mini block heat and generating plants ...) up to the level of the individual consumer (thus becoming "prosumer"). Renewable energy have however the drawback of being unpredictable energy sources;
- Decrease the dependency on fossil fuels by enabling the switch over to hybrid or electric cars;

The above requires a more intelligent control of the electricity grid and the interaction between the grid operator/energy producer and the prosumer, in order to avoid demand peaks and surplus production by:

- managing loads, up to the level of individual homes;
- use storage capacity at the prosumer (e.g. his electrical car) to store surplus energy (during low demand) or to recuperate energy (during high demand).

In order to do so, the smart meter

- will introduce more complex tariff structures to encourage or discourage energy consumption, in order to promote the use of green energy;
- should keep the inhabitant of home and building informed on his energy consumption to decrease or remedy excessive energy consumption;

As a result of the mandate and by the installed Smart Metering Coordination Group between the ESOs, CENELEC TC205 has been appointed as the group responsible for definition of appropriate interfaces between the future smart meter and the smart home.

2 Scope

This document describes the advantages of the use of

- home and building electronic systems (HBES) to increase the selling argument for smart metering infrastructure;
- the already available solutions for interaction between smart meters and smart home or building infrastructure based on the EN 50090 standard (HBES Open Communication System).

3 Limits to the use of conventional installation techniques

The following limits shall be noted when opting for conventional home and building installation techniques in conjunction with smart meters:

- When a smart meter informs the user on excessive energy consumption, the user is unable to find out the reason for this and can consequently not remedy the situation.
- Only displaying energy consumption data and especially the overall energy consumption can be misleading (if measured over too short periods) and hard to interpret by laymen.

- If consumption data can only be consulted via a web portal of the energy provider, consultations will become increasingly sporadic and the awareness effect of the user will dwindle. In remote areas, web portals may not even be an option;
- In order to avoid a multitude of displays for all energy consumption data (gas, electricity, heat costs, water), a central manufacturer independent display is indispensable.
- Displaying consumption data does not automatically save energy: intelligence is needed to switch off loads, whereby the biggest potential can be gained if this intelligence is also able to influence consumption for lighting and heating, ventilation and air conditioning systems.
- The direct switching of loads can cause discussions on privacy, whereby the user may insist on consuming energy in spite of higher tariffs.
Switching off loads (e.g. appliances) in the middle of the execution of a program without the knowledge of their status may even be unwanted.
Consumer goods like home appliances are changing elements of a fixed installation: when renewed or repaired, the link between home appliances and the smart meter must be easily re-established.
- Today, the implications of the increased future use of the electric car and/or energy production are still unclear, so that a conventional solution may well have inherent limits or not be extendable.
- The management and integration of all elements in the home or building (loads, information to the user and energy production) is a complex task that can not be handled by the meter or grid provider alone.

4 Advantages of the use of smart home and building infrastructure

Apart from avoiding the above elements, the use of a smart home and building infrastructure has the following advantages:

- HBES is scalable: first implementations can be limited to smart metering only (e.g. displaying of consumption data) but are easily extendable;
- HBES systems increase comfort and security;
- HBES provides answers for changing social trends, which anyway require the increased use of ICT in homes and buildings;
 - o Ageing of people (Ambient Assisted Living);
 - o Increase in single person households
 - o Both adults in families working
 - o Increased urbanization
 - o Shrinking resources
- HBES Systems can be remotely accessed to read out the status of, maintain and reconfigure individual networked devices;

5 Additional advantages of the HBES Open Communication System according EN 50090 (KNX)

The use of the HBES Open Communication System according EN 50090 offers the following additional advantages:

- International standardisation implies guaranteed availability over a larger time span;
- Reduced use of gateways leads to an increased simplicity of installation and acceptance of smart metering;
- Wide choice of interoperable and to a large extent KNX certified material from different providers for the realisation of many applications in the home;
- Wide network of qualified contractors and integrators to
 - o Ensure link between smart meter and smart home
 - o Engineer an installation tailored to the needs of the customer
 - o Easy adaptations of installation to future needs
- Choice of configuration possibilities
 - o Non-PC based (controller, push button mode)
 - o PC based (via Engineering Tool Software) – for full scale integration
- Choice of 4 different media to ensure link between smart meter and home, including encryption possibilities
 - o Twisted Pair (new homes – increased security)
 - o Power line (existing homes, retrofit)
 - o KNX Radio Frequency (retrofit, extensions), compatible with M-Bus wireless S-Mode (standardised in EN 13757-3)
 - o IP including WiFi (increasingly omnipresent)

6 Available solutions based on HBES Open Communication System according EN 50090 (KNX)

The HBES Open Communication System KNX allows the realization of the following smart metering applications, in order of increasing offered functionality.

6.1 Collecting and providing metering data

Metering Data can be generated by multiple meters and metering sensors in the home or building.

KNX provides the means to collect this rich information and make it available in a systematic way.

For this purpose, KNX has specified a KNX Metering M-Bus Data Collector, as documented in Volume 10 of the KNX Specifications. The device allows the collection of metering data compliant with EN13757-3 and EN13757-4 (S Mode).

The specification describes the standardised mapping of a substantial set of M-BUS DIF, DIFE, VIF and VIFE encodings. Though covering the majority of the implementations on the market, thanks to the common approach, additional mappings can easily be added. The most common M-Bus media can be mapped including heat, water and warm water, heat cost allocation, cooling load (inlet and outlet), heat (inlet) and heat and cool. Recently mapping of gas and electricity meter data has been added.

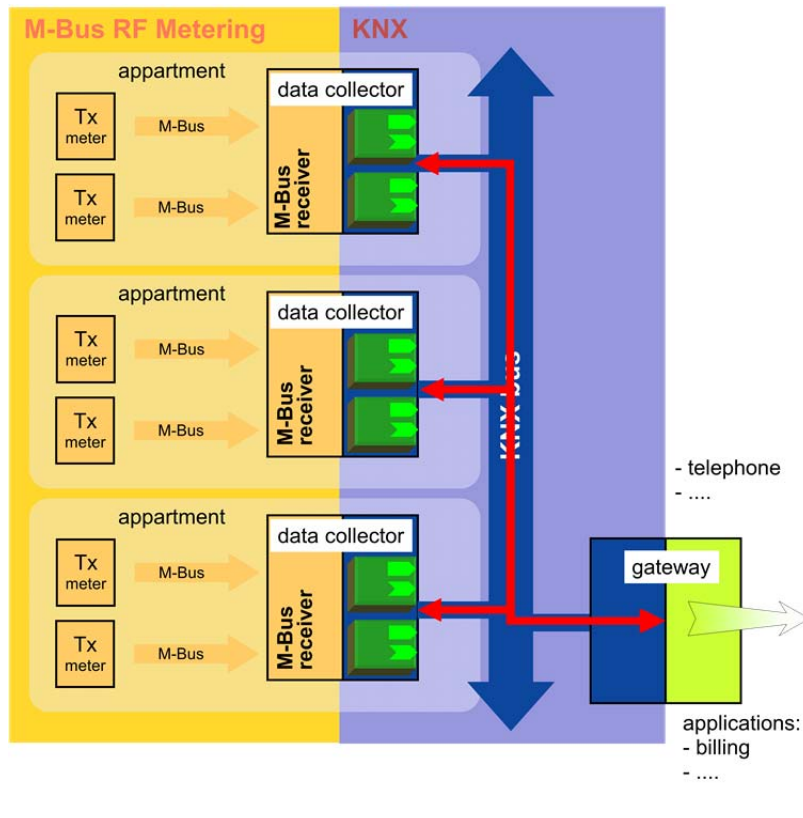

One KNX M-Bus Data Collector can receive, filter and interpret M-Bus Data of up to eight meters, each represented by a KNX Interface Object.

That KNX interface object holds static data of the meter, like manufacturer, identification number, version, medium... as well as variable data, like operating time, dates and values for minimal and maximal metering data, information on errors and other. The Interface Object even allows storing the raw M-Bus telegram data.

For each storage number, the history date, the energy consumption and the minimal and maximal flow and power are stored.

The KNX M-Bus Data Collector acts as a server, holding the data of these 8 meters available for any client to read from remote. In all of this, great care is taken to maintain data integrity.

As this model, originally designed to represent M-Bus meters on KNX, is very complete, it can be used as the basic model for all possible other generic meters or metering interfaces (pulse counters, SO-interface...).

Tech talk

KNX Group Objects are the cornerstone of KNX's **producer/consumer** communication model. They constitute small data structures containing elementary data, transmitted on KNX using Group Addresses.

KNX Interface Objects are the cornerstone of the KNX **Client/Server** communication model. They can hold rich sets of well-defined, identified, typed pieces of data, named **Properties**, which a client can read in point-to-point communication.

Functional Blocks (FBs) are the basic building element used to model KNX applications. Functional Blocks are a theoretical model based on IEC 61131-3 and independent of the Configuration Mode or Communication Medium, as laid down in EN 500909-3-3. About 140 FBs are currently defined. When applied, their Inputs and Outputs are realised as Group Objects or Properties of KNX Interface Objects.

6.2 Displaying metering data

6.2.1 Introduction

Whereas the above focuses on reliably gathering metering data, this function focuses on the communication of metering data inside the home or building.

In combination with the wide variety and richness of tariff – and cost information delivered at any home interface, advanced visualisation and statistics of metering data can be realized in displays (histograms, extremes, trends...).

Display of metering data raises the customer acceptance and guarantees longer lasting, permanent user awareness. The full integration of this display functionality in central home management consoles (touch screens, visualisations...) will moreover make consumption and cost awareness a real natural aspect of the daily experience in the home.

6.2.2 Possible realisations based on KNX

In all cases, the interface to the meter and the KNX display are connected to one of the available KNX media, chosen as best fit.

- I. The first solution relies on the before described KNX M-Bus Data Collector: this device makes available key consumption data as Group Objects for spontaneous transmission on KNX (Figure 1). A central KNX compatible display constitutes the sink for this information.

EXAMPLE 1 DPT_Power (9.024, F₁₆, unit: 0,01 kW)

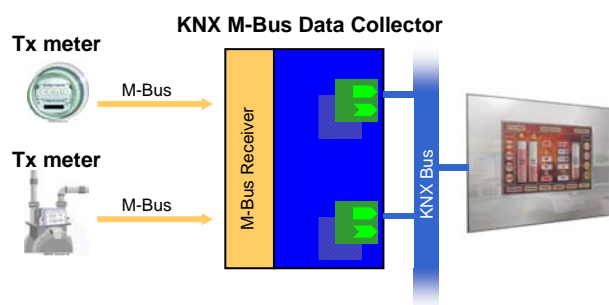

Figure 1 – The display is fed by the KNX M-Bus Meter with KNX module snapped on

- II. A second possibility consists of the use of various existing couplings to meters that use modules *snapped on* the meter, catching elementary meter events per measured unit (ticks, electrical pulses, infrared, reflection, customer information data via serial interface link, ...).

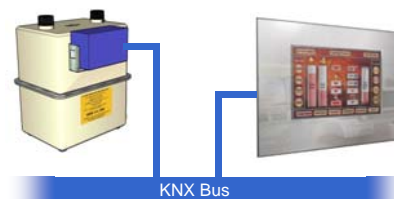

Figure 2 – Snap-on modules catch every measured metering element

The before said snap on KNX compatible modules either

- provide the metering data directly to a home display via KNX, as is the case in solution I above;
- or combine the time and date information (DPT_DateTime, 9.001) - often available in the installation to drive time schedulers and controllers for various applications - with the captured metering events and build detailed load profiles.

A central client, for instance in the home display or in the Internet coupling to KNX, then retrieves this large data set using the *FTP over KNX* protocol.

Tech talk

KNX FTP denotes a lightweight protocol for transferring larger sets of data on KNX, similar to FTP on IP. Any metering data (values, times...) can be stored in a device in a file that is then retrieved via FTP for instance once per day, for further analysis and interpretation.

- III. The easiest and most powerful connection is offered by a meter with integrated KNX coupling. Several 3rd party providers have commercial offers for communication stacks and electronics (chips, modules or schema) that allow for a quick and easy development of such meter. On KNX TP1, the meter can even draw additional power from the KNX medium.

KNX compatible meter

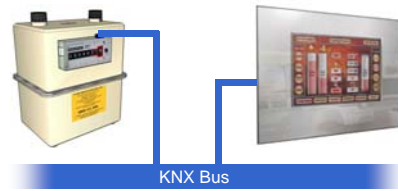

Figure 3 – Meter directly connected to KNX

6.2.3 Finding the source of excessive energy consumption

In larger installations, it may be interesting for the building manager, to have more detailed knowledge of where the energy flows.

As KNX can be the means to measure, control and manage this consumption, it naturally offers the best fit infrastructure to return back information from the controlled load into the system.

EXAMPLE 2 KNX can control a variety of electrical devices (lighting, shutters & blinds, fans, pumps...). The knowledge or the measurement of the connected load, in combination with the knowledge of the operation times, allows very precise knowledge of the consumption of the connected device.

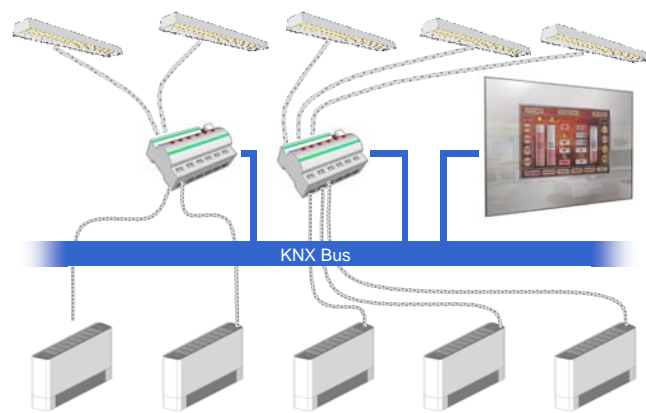

Figure 4 – Electrical consumption of appliances measured and controlled by KNX

6.3 Avoiding unwanted consumption

6.3.1 Autonomous Load Management

Energy providers as well as consumers have interest in avoiding excessive - or badly timed consumption. This will ease and help guarantee the control of the production and distribution and finally avoid unnecessary costs.

The avoidance of *Peak Loads* in the (electricity) consumption may be the obvious example. KNX, as worldwide standard for home and building automation, controls the loads in many homes and buildings. KNX devices are thus present where the action takes place: where loads are switched and controlled. The intelligence of these devices and controllers, and the KNX communication network all around, can support avoiding peak loads.

This is worked out in the *KNX Load Management Model* as shown in Figure 5. (This model does not yet show the influence of the current valid external tariff information and realizes load management of the installation autonomously.) The *Application Manager* is an application specific supervision in the installation. It contains a *Load Management* function that collects consumption information in several ways.

- I. If individual appliances or groups of these know their flow consumption, either current, next – or scheduled, then they can report this via KNX. This can be realized by any combination of the above meter data acquisition methods.
- II. The *Load Management* function can also take into account past consumption information. Any repeated pattern allows *load prediction* of even conventional, not-smart loads.
- III. Obviously, the Load Management function may have own scheduling- and calendar information about the loads that it controls.

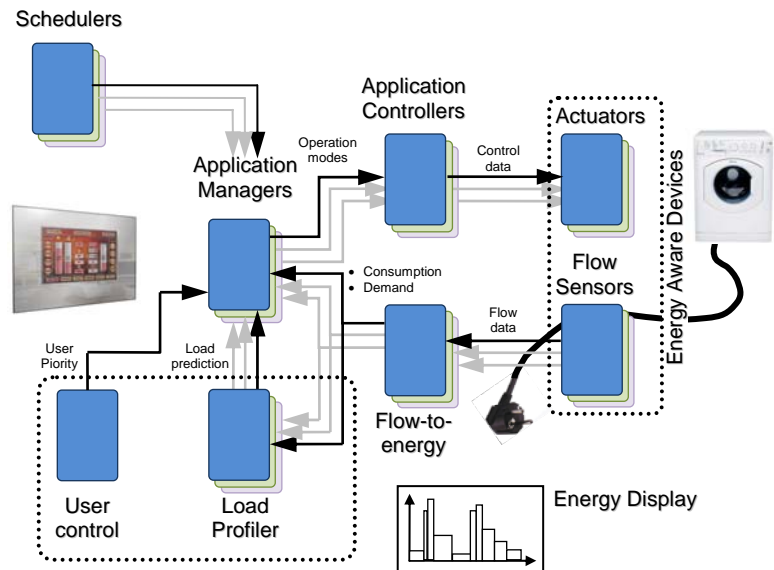

Figure 5 – Load Management with KNX (not all links are drawn)

The information from these three sources allows building a *global consumption profile* of the installation. This can be an interesting source for interpretation by the energy provider or the smart grid operator.

EXAMPLE 3

The *White Goods Application Manager* concludes on the operation of the white goods.

The *White Goods Application Controller* knows the details of the operation of the various appliances and controls the *White Goods Actuator*, this is, the appliance.

Through current sensor and flow meters, the consumption of electricity and water can be measured. This is shifted back to the Application Manager.

The scheme also allows the appliance to demand or announce a required power. The Application Manager finally concludes whether the operation of the appliance can take place as requested or should be shifted.

Tech talk

DPT_Value_Volume_Flow (DPT_ID = 9.025) encodes water flow in l/h; DPT_UeICurrentmA (DPT_ID = 7.012) or DPT_Value_Electric_Current (DPT_ID = 14.019) encode electrical current. In order to build Load Profiles, DPT_DateTime (DPT_ID = 19.001) can be used. The data of the schedulers is application specific; the general building mode can for instance be encoded using DPT_BuildingMode (DPT_ID = 20.002) or DPT_HVACMode (DPT_ID = 20.102).

6.3.2 Tariff aware Load Management

The smart grid also builds a digital access path from the smart grid operator or energy providers into the home. The interface can be a smart meter, a home access point (e.g. MUC/M2M gateway) or an Internet service.

Thanks to this, the concept of conventional simple and rather static tariff indications as known from the past century is turned into an approach with tariff plans, which can be rich and dynamic packages of information.

Such tariff plan may contain current, next and future energy prices, but also exceptional offers. It may hold other aspects, like the origin of electrical energy.

The handling of this data arriving at the doorstep depends on several factors.

- I. Obviously, this will depend on *the medium*. Tariff and Load Management data will be handled in a different way for electricity, gas or water and how these are used.

EXAMPLE 4 The electricity can be used for lighting, but possibly also for (additional) electrical heating. Gas can be used for heating, but also for hot water heating, cooking, etc.

- II. One medium can thus be used in various applications: HVAC, white goods, lighting, security functions, etc. The data handling will thus depend on the flexibility of *the application* and its current state.

EXAMPLE 5 The operation of a washing machine can be shifted in time with a certain deadline. An electrical heating appliance in an emergency warming up will be more reluctant to adapting.

The examples show that medium and application are used in various combinations. If we add to this the geographical dependencies and diversity of the applications, then it becomes clear that the solution shall base on a generic, distributed and future proof model. This is solved by the application model in Figure 6.

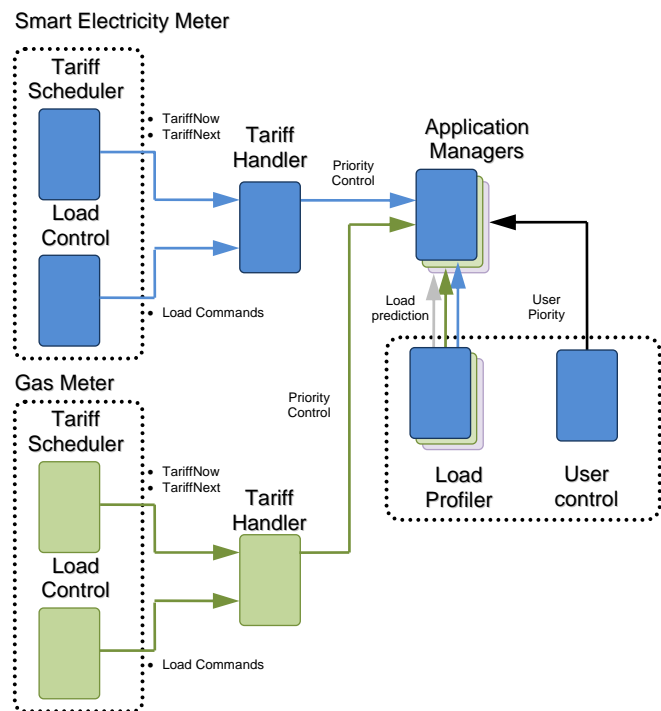

Figure 6 – Tariff and Load Management with KNX

Tech talk

A wide variety of tariff definitions exist worldwide. The tariff information is interpreted by the FB Tariff Handler (communicated to the KNX installation via DPT_Tariff (DPT_ID = 5.006) or DPT_TariffNext (DPT_ID = 236.001), which through its parameterisation suggests load management adjustments to the KNX network using DPT_Prioritised_Scene_Control (DPT_ID = 236.001).

6.3.3 Reaction of homes and buildings to blackouts

Quality and reliability hides also in the handling of errors and exceptions, i.e. proper reaction of a home or building on a blackout respectively friendly behaviour on power return, without any unpredictable behaviour.

Reactions of devices to such situations are an inherent part of the KNX Interworking Model as laid down in EN 50090-3-3 and the KNX standard Functional Blocks. Wired installations can moreover be equipped with UPS.

6.4 Saving energy

It is a scientifically proven fact that the use of control equipment in homes and buildings has a considerable positive impact on overall energy consumption, thanks to the smart optimisation algorithms of the applications (HVAC, lighting, shutters...) and communication between these applications, as referred to above.

This has also been proven in numerous KNX projects in the field.

EXAMPLE 6 Sensors ensure that in case of opened windows, the heating or the air conditioning is automatically switched off.

EXAMPLE 7 Presence detectors ensure that only rooms are heated/cooled and/or lit when occupied.

EXAMPLE 8 Light intensity sensors switch or dim the artificial light in function of the outdoor brightness.

The use of smart control like KNX therefore does not only raise awareness for one's energy consumption, it also provides means for the home and the building occupant to actually save energy. This in a world where energy is an increasingly important factor in the operating costs of a home or a building.

Yet, with integrated smart meters this smart building grows further from an isolated functioning island into a part of a wide, smart network. Communication in both ways, energy demands and tariff announcements, will allow both processes to influence each other. KNX allows services from outside the home- or building to access appliances and applications over a standard addressing and access path.

As the KNX Functional Blocks are common and generic, interaction with KNX does not require considering all details of the applications or any solution specific constraints.

The architecture is inherited from the above use case, but the additional data allows for a higher optimisation class.

6.5 Energy production and back up

An entire parallel world may see the light if *micro-generators* are networked and become part of the Smart Grid. KNX would allow such energy sources to report on their current and estimated power - or energy production.

- The home intelligence can control and co-ordinate this production.
- It interacts with the rest of the networked applications.
- It may further also feed information towards the grid about the available power (current, minimal and maximal values...) and its dynamics (availability, scheduling...).

The application model for KNX Energy Management is sketched in Figure 7.

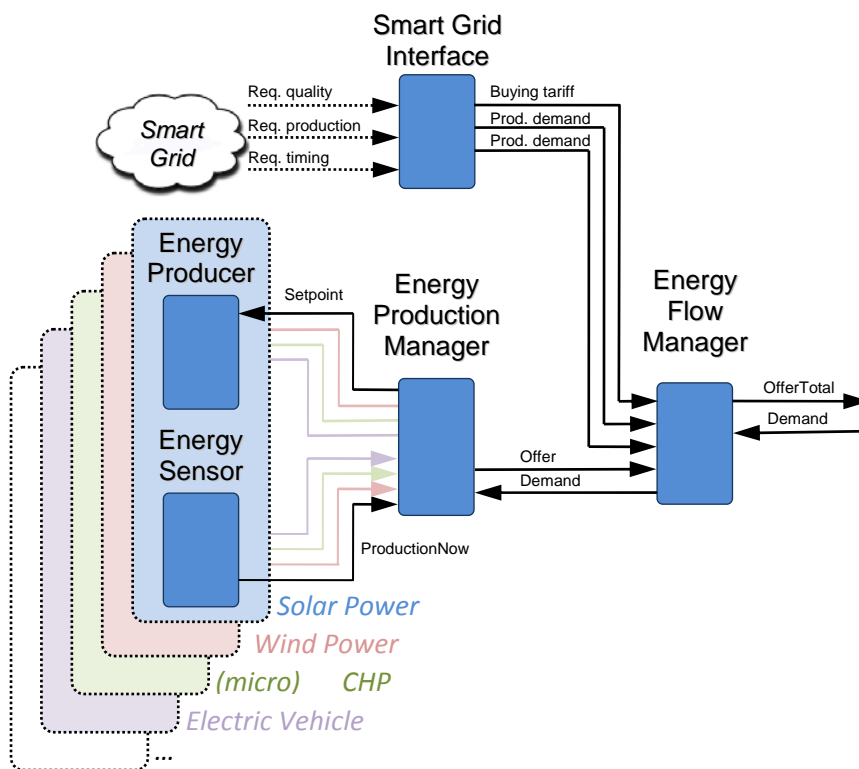

Figure 7 – Production of electrical energy and Smart Grid Interface in the KNX Energy Management model

Amongst other, the *smart grid operator* provides commercial information about the required quality, timing and purchase process.

The home network may merely be a means of transport to convey controls towards the micro production.

It may also process this information in an intelligent way, to further optimize production, or coordinate with the own consumption.

An interesting use case pops up with the introduction of electric vehicles. Though ecologically appealing, these will build a new type of load for the

electrical power network. It has its own energy amounts, its own point in time when this energy is needed and also puts limitations of how this energy consumption can be spread or scheduled. A peculiarity may be the fact that the battery may shortly inject current back into the home electricity network, to help coping with short peak demands and thus also avoid peak loads on the public net.

This gives an overall image of control and scheduling of energy consumption and energy production, the co-ordination between both and the standard access in and out the home, are new challenges for models solved with KNX.

7 Conclusion

KNX, as Cooperating Partner to CENELEC for Home and Building Electronic Systems, is prepared to provide its technical specifications for the above described solutions as input for international standardisation.