

This PDF is available at <http://nap.edu/24619>

SHARE    

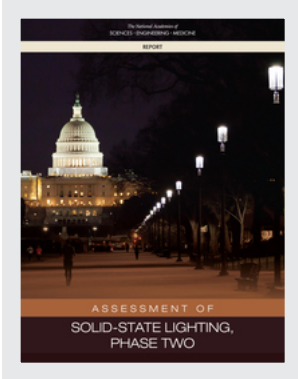

Assessment of Solid-State Lighting, Phase Two

DETAILS

116 pages | 8.5 x 11 | PAPERBACK
ISBN 978-0-309-45257-1 | DOI 10.17226/24619

CONTRIBUTORS

Committee on Assessment of Solid-State Lighting, Phase 2; Board on Energy and Environmental Systems; Division on Engineering and Physical Sciences; National Academies of Sciences, Engineering, and Medicine

GET THIS BOOK

FIND RELATED TITLES

Visit the National Academies Press at NAP.edu and login or register to get:

- Access to free PDF downloads of thousands of scientific reports
- 10% off the price of print titles
- Email or social media notifications of new titles related to your interests
- Special offers and discounts



Distribution, posting, or copying of this PDF is strictly prohibited without written permission of the National Academies Press. (Request Permission) Unless otherwise indicated, all materials in this PDF are copyrighted by the National Academy of Sciences.

Copyright © National Academy of Sciences. All rights reserved.

ASSESSMENT OF SOLID-STATE LIGHTING, PHASE TWO

Committee on Assessment of Solid-State Lighting, Phase 2

Board on Energy and Environmental Systems

Division on Engineering and Physical Sciences

A Report of

The National Academies of

SCIENCES • ENGINEERING • MEDICINE

THE NATIONAL ACADEMIES PRESS

Washington, DC

www.nap.edu

THE NATIONAL ACADEMIES PRESS • 500 Fifth Street, NW • Washington, DC 20001

This activity was supported by Grant No. EE-0007045 from the U.S. Department of Energy. Any opinions, findings, conclusions, or recommendations expressed in this publication do not necessarily reflect the views of any organization or agency that provided support for the project.

Cover: The elm path on the National Mall is shown illuminated by light fixtures originally installed in 1936 and which were specified by Frederick Law Olmsted, Jr., as 21 foot tall, 300-pound, fluted bronze base and cast iron light fixtures. The retrofit kits were provided by OSRAM Sylvania and installed by PEPCO, a DC-area utility. The public domain image was photographed by Quentin Kruger in January 2012.

International Standard Book Number-13: 978-0-309-45257-1

International Standard Book Number-10: 0-309-45257-0

Digital Object Identifier: <https://doi.org/10.17226/24619>

Additional copies of this publication are available for sale from the National Academies Press, 500 Fifth Street, NW, Keck 360, Washington, DC 20001; (800) 624-6242 or (202) 334-3313; <http://www.nap.edu>.

Copyright 2017 by the National Academy of Sciences. All rights reserved.

Printed in the United States of America

Suggested citation: National Academies of Sciences, Engineering, and Medicine. 2017. *Assessment of Solid-State Lighting, Phase 2*. Washington, DC: The National Academies Press. doi: <https://doi.org/10.17226/24619>.

The National Academies of
SCIENCES • ENGINEERING • MEDICINE

The **National Academy of Sciences** was established in 1863 by an Act of Congress, signed by President Lincoln, as a private, nongovernmental institution to advise the nation on issues related to science and technology. Members are elected by their peers for outstanding contributions to research. Dr. Marcia McNutt is president.

The **National Academy of Engineering** was established in 1964 under the charter of the National Academy of Sciences to bring the practices of engineering to advising the nation. Members are elected by their peers for extraordinary contributions to engineering. Dr. C. D. Mote, Jr., is president.

The **National Academy of Medicine** (formerly the Institute of Medicine) was established in 1970 under the charter of the National Academy of Sciences to advise the nation on medical and health issues. Members are elected by their peers for distinguished contributions to medicine and health. Dr. Victor J. Dzau is president.

The three Academies work together as the **National Academies of Sciences, Engineering, and Medicine** to provide independent, objective analysis and advice to the nation and conduct other activities to solve complex problems and inform public policy decisions. The National Academies also encourage education and research, recognize outstanding contributions to knowledge, and increase public understanding in matters of science, engineering, and medicine.

Learn more about the National Academies of Sciences, Engineering, and Medicine at www.national-academies.org.

The National Academies of
SCIENCES • ENGINEERING • MEDICINE

Reports document the evidence-based consensus of an authoring committee of experts. Reports typically include findings, conclusions, and recommendations based on information gathered by the committee and committee deliberations. Reports are peer reviewed and are approved by the National Academies of Sciences, Engineering, and Medicine.

Proceedings chronicle the presentations and discussions at a workshop, symposium, or other convening event. The statements and opinions contained in proceedings are those of the participants and have not been endorsed by other participants, the planning committee, or the National Academies of Sciences, Engineering, and Medicine.

For information about other products and activities of the National Academies, please visit nationalacademies.org/whatwedo.

COMMITTEE ON ASSESSMENT OF SOLID-STATE LIGHTING, PHASE 2

JOHN KASSAKIAN, NAE,¹ Massachusetts Institute of Technology, *Chair*

EVELYN HU, NAS²/NAE, Harvard University, *Vice Chair*

IAIN BLACK, Lumileds

NANCY E. CLANTON, Clanton & Associates

WENDY DAVIS, University of Sydney

MICHAEL ETTENBERG, NAE, Dolce Technologies

PEKKA HAKKARAINEN, Lutron Electronics

NADARAJAH NARENDRAN, Rensselaer Polytechnic Institute

MAXINE SAVITZ, NAE, Honeywell, Inc. (retired)

MICHAEL G. SPENCER, Cornell University

CHING TANG, NAE, University of Rochester

Staff

MARTIN OFFUTT, Study Director

JAMES ZUCCHETTO, Director, Board on Energy and Environmental Systems

DANA CAINES, Financial Manager

LaNITA JONES, Administrative Coordinator

ELIZABETH EULLER, Program Assistant

¹ National Academy of Engineering.

² National Academy of Sciences.

BOARD ON ENERGY AND ENVIRONMENTAL SYSTEMS

JARED COHON, NAE,¹ Carnegie Mellon University, *Chair*
DAVID ALLEN, University of Texas, Austin
W. TERRY BOSTON, NAE, PJM Interconnection, LLC
WILLIAM BRINKMAN, NAS,² Princeton University
EMILY A. CARTER, NAS/NAE, Princeton University
BARBARA KATES-GARNICK, Tufts University
JOANN MILLIKEN, Independent Consultant, Alexandria, Virginia
MARGO OGE, Office of Transportation and Air Quality, Environmental Protection Agency
JACKALYNE PFANNENSTIEL, Independent Consultant, Piedmont, California
MICHAEL RAMAGE, ExxonMobil Research and Engineering Company (retired)
DOROTHY ROBYN, Consultant, Washington, D.C.
GARY ROGERS, Roush Industries
KELLY SIMS-GALLAGHER, The Fletcher School, Tufts University
MARK THIEMENS, NAS, University of California, San Diego
JOHN WALL, NAE, Cummins Engine Company (retired)
ROBERT WEISENMILLER, California Energy Commission

Staff

K. JOHN HOLMES, Acting Director/Scholar
JAMES ZUCCHETTO, Senior Scientist
DANA CAINES, Financial Associate
LINDA CASOLA, Senior Program Assistant (until September 2016)
LaNITA JONES, Administrative Coordinator
JANKI PATEL, Program Assistant
MARTIN OFFUTT, Senior Program Officer
BEN WENDER, Associate Program Officer
E. JONATHAN YANGER, Research Associate (until April 2017)

¹ NAE, National Academy of Engineering.

² NAS, National Academy of Sciences.

Preface

The penetration of solid-state lighting (SSL) has increased dramatically since the publication of the National Research Council¹ (NRC) report *Assessment of Advanced Solid-State Lighting* in 2013.² The Committee on Assessment of Solid-State Lighting, Phase 2 has been surprised by this rapid adoption and the accompanying diversity of applications of SSL, which has been driven largely by the dramatic decline in the retail price of lamps and luminaires, and recognition of the unique qualities of the light emitting diode (LED) light source. Improvements in lamp performance, the introduction of innovative applications, improved compatibility of lamps with controls, and the integration of LED lamps in systems have all contributed to this rapid acceptance. Examples of exploiting the special characteristics of SSL are the introduction to steerable headlamps in cars, the use of spectral control to prevent lighting-induced damage to artwork, and more efficient and controllable street lighting. Accompanying this growth in the SSL market has been the rapid decline of compact fluorescent lamps (CFLs) from retailer shelves.

The penetration in the United States of LED lamps and luminaires has increased by approximately 35 percent since 2013 (although LEDs represent only 6.4 percent of the installed lighting base [i.e., the number of units]), and the cost per lumen has dropped dramatically. The relative ease with which companies can enter the SSL market has created challenges for established lighting manufacturers, and some have been unable to make a financially successful transition from legacy products to SSL. Those that have succeeded have left the lamp business and entered the systems business, which is perhaps the most dramatic development in SSL deployment. Some of these systems displace conventional light sources with LED sources having superior spectral and control characteristics. Others exploit the color controllability of the LED to create new applications. An example of the former is the use of LED lighting in horticulture, where the low energy requirement and spectral tuning ability combine to create a growing market. The ability to modulate LED output at high frequencies has led to the developing area of “Li-Fi” (light fidelity) systems—the dual use of LEDs for both lighting and local area communications. The recent attention to the human and ecological response to light of different wavelengths has created interest in using the color tuning ability of LEDs to mitigate or enhance these

¹ Effective July 1, 2015, the institution is called the National Academies of Sciences, Engineering, and Medicine. References in this report to the National Research Council are used in an historical context identifying programs prior to July 1.

² National Research Council, 2013, *Assessment of Advanced Solid-State Lighting*, Washington, D.C.: The National Academies Press.

effects, as appropriate—for example, by promoting the production of melatonin in those with seasonal affective disorder (SAD).

The manufacture of LED devices and conventional A-lamps has largely migrated offshore, although some device manufacturing remains in the United States for high-performance LEDs. The design and manufacture of LED luminaires, however, remain within the United States and could be a substantial growth industry. The opportunity for creative and innovative luminaire and lighting designs made possible by LED (and the organic light emitting diode [OLED]) light sources has been aggressively engaged by both luminaire manufacturers and lighting designers.

Early application of existing controls with LED lighting presented compatibility issues manifested as flicker, interference, and other unsatisfactory behavior. These issues have been largely overcome by control manufacturers but still require some diligence on the part of the consumer and professional designer in selecting controls and lamps.

The efficiency and cost of OLED lighting have both improved since the 2013 report, but cost as well as manufacturing challenges remain. There is, however, the promise of leveraging the extensive OLED display infrastructure, primarily in Korea, to the benefit of OLED lighting. Also on the horizon is the continuing development of solid-state laser-based light sources, which use a blue laser to excite the phosphor. They are already being incorporated in high-end automotive headlamps.

The reports on advanced solid-state lighting by the National Academies of Sciences, Engineering, and Medicine were undertaken at the request of Congress in the Energy Independence and Security Act (EISA) of 2007. The first report addressed the impact of the new standards for lighting efficiency that were included in EISA, barriers and opportunities of large-scale deployment of SSL, and technology development and applications. In the present report, the committee has focused on three key areas: commercialization (noting the rapid deployment of SSL since the 2013 report), technology development (updating the findings of the 2013 report), and manufacturing. In the process, the committee has taken the opportunity to update material in this report that was presented in the earlier study. Funding has been provided by the U.S. Department of Energy via the lighting program directed by James Brodrick, Ph.D.

John G. Kassakian, *Chair*
Committee on Assessment of Solid-State Lighting, Phase 2

Acknowledgment of Reviewers

This report has been reviewed in draft form by individuals chosen for their diverse perspectives and technical expertise. The purpose of this independent review is to provide candid and critical comments that will assist the institution in making its published report as sound as possible and to ensure that the report meets institutional standards for objectivity, evidence, and responsiveness to the study charge. The review comments and draft manuscript remain confidential to protect the integrity of the deliberative process. We wish to thank the following individuals for their review of this report:

William Brinkman, NAS,¹ Princeton University,
George Craford, NAE,² Lumileds,
Steven DenBaars, NAE, University of California, Santa Barbara,
Elsa Garmire, NAE, Dartmouth College,
Rachel Goldman, University of Michigan, Ann Arbor,
Noah Horowitz, Natural Resources Defense Council,
Raj Jayaraman, Philips Lighting Electronics North America,
Julia Phillips, NAE, Sandia National Laboratories, and
Alison Silverstein, Independent Consultant.

Although the reviewers listed above have provided many constructive comments and suggestions, they were not asked to endorse the conclusions or recommendations nor did they see the final draft of the report before its release. The review of this report was overseen by William F. Banholzer, University of Wisconsin, Madison, who was responsible for making certain that an independent examination of this report was carried out in accordance with institutional procedures and that all review comments were carefully considered. Responsibility for the final content of this report rests entirely with the authoring committee and the institution.

¹ National Academy of Sciences.

² National Academy of Engineering.

Contents

SUMMARY	1
1 INTRODUCTION	4
Context, 4	
Study Origin, 4	
Introduction to Lighting, 5	
Light Intensity and Efficacy, 5	
Light Color Properties, 6	
Relationship Between Color and Efficacy, 6	
Lighting Quality, 6	
Electricity Consumed by Lighting in the United States, 8	
Overview of LED Application Types, 8	
References, 10	
2 PUBLIC POLICY AND DEPLOYMENT OF NEW LIGHTING TECHNOLOGIES	11
Introduction, 11	
Global Lighting Market: Status and Potential, 11	
United States Forecasts, 11	
Department of Energy Lighting Program, 16	
Recent Changes in Federal and State Programs, 20	
Federal Laws and Regulations, 20	
Federal Voluntary and Procurement Programs, 23	
State Laws, Regulations, and Voluntary Programs, 24	
Recent Changes in Industry Codes and Standards, 26	
Building Codes, 26	
Industry Standards, 26	
Recent Changes in Incentive Programs, 28	
Public Policy and Market Transformation Outside the United States, 29	
Europe, 29	
Japan, 30	
Other Countries and Regions, 30	
References, 30	
3 ASSESSMENT OF LED AND OLED TECHNOLOGIES	32
Introduction, 32	
Key Core Technology Challenges for LEDs, 33	
Eliminating or Mitigating “Current Droop,” 34	
Overcoming the “Green Gap,” 37	

Control Over Color Quality, 38	
Improved Epitaxial Growth and Substrates, 40	
Challenges and Promises for LEDs, 40	
Key Core Technology Challenges for OLEDs, 41	
Incipient Commercialization of OLED Lighting, 42	
Lifetime Issues, 43	
Best Research Results for OLED Lighting Panels, 43	
Novel Approaches to Enhanced OLED Performance, 44	
Challenges and Promises for OLEDs, 44	
Summary and Comparison of LED and OLED SSLs, 45	
References, 46	
Annex 3.A: An LED Primer, 47	
Annex 3.B: An OLED Primer, 52	
4 SSL APPLICATIONS	56
Solid-State Lighting Systems, 56	
Current Applications of SSL, 56	
Lighting Control Trends, 57	
Automotive Applications, 58	
Retrofit Applications, 58	
Current Challenges, 59	
LED System Lifetime, 60	
Emerging SSL Applications, 60	
Spatial Distribution and Form Factors, 61	
Lighting for Health, 61	
Horticultural Lighting, 62	
Livestock Lighting, 63	
Smart Lighting, 65	
Impediments to Innovation, 65	
Lighting Metrics, 66	
Product Design and Specification, 66	
Future Approaches to Reducing Energy Consumption, 67	
References, 68	
Annex 4.A: Subcomponents of an SSL Product, 71	
5 MANUFACTURING	74
Introduction, 74	
The Manufacturing Supply Chain and Economic Drivers, 74	
LEDs, 74	
Packaging and Packageless LEDs, 76	
Low-Power and Medium-Power Packages, 76	
High-Power Packages, 76	
Package-Free Technology, 76	
Lamps and Luminares, 77	
Lamps/Lamp-Based Luminaires, 79	
LED Luminaires (1st Generation), 79	
LED Luminaires (Next Generations), 79	
Economic Drivers in the United States, Europe, and Asia, 80	
OLEDs, 81	
OLED-SSL Products, 81	
OLED-SSL Product Cost, 81	
OLED-SSL Manufacturing, 83	
References, 84	

CONTENTS

xiii

APPENDIXES

A Committee Biographical Information	87
B Committee Meetings and Presentations	90
C Nomenclature and Definitions	92
D Acronyms and Abbreviations	100

Summary

INTRODUCTION

Since the publication of the 2013 National Research Council¹ (NRC) report *Assessment of Advanced Solid-State Lighting* (NRC, 2013), the penetration of solid-state lighting (SSL) has increased dramatically, with a resulting savings in energy and costs that were foreshadowed by that study. What was not anticipated then is the dramatic dislocation and restructuring of the SSL marketplace, as cost reductions for light-emitting diode (LED) components reduced profitability for LED manufacturers. At the same time, there has been the emergence of new applications for SSL, which have the potential to create new markets and commercial opportunities for the SSL industry. This report will discuss these aspects of change—highlighting the progress of commercialization and acceptance of SSL and reviewing the technical advances and challenges in achieving higher efficacy for LEDs and organic light-emitting diodes (OLEDs). The report will also discuss the recent trends in SSL manufacturing and opportunities for new applications and describe the role played by the Department of Energy (DOE) Lighting Program in the development of SSL.

In 2014, approximately 15 percent of all retail electricity used in the United States was consumed by lighting. Since that time, the commercialization of lighting products utilizing LEDs has grown dramatically. Projections suggest that LED products will account for 48 percent of installed lighting service in 2020 and 84 percent in 2030—with lighting expected to consume 14 percent of electricity in 2020 and 11 percent in 2030. However, only 6.4 percent of U.S. general illumination, measured in number of installations, was provided by LEDs in 2015.

Solid-state lighting is an ever-expanding technology that is now widely accepted within the design and commercial

building industries and growing in popularity with the general public. During the early stages of commercialization, the most common SSL products have been LED lamps and luminaires that replicated existing legacy form factors, such as general service “A-lamps” (the familiar “light bulb”), recessed troffers, and cobra-head-style luminaires for street and roadway lighting. These have been used in applications similar to their legacy lamp predecessors. One might characterize these early stages as constituting a first wave of commercialization, with key acceptance factors being cost and potential energy savings.

In recent years, there has been evidence of a second wave of commercialization emerging—that is “smart” and feature-rich—in which new applications for SSL leverage factors beyond efficacy alone, focusing on the quality and form factors of lighting, their connectivity, “smartness,” and controllability. Embracing these new applications can provide new markets and thus sustained growth for SSL.

COMMERCIALIZATION AND ACCEPTANCE OF SSL

The penetration of LED-based SSL has increased dramatically since the 2013 NRC report. There remains, however, a large opportunity for SSL products worldwide: in 2010 there were about 4 billion incandescent and halogen lamps installed in the residential sector. Within the United States, DOE has regulated traditional lighting products (incandescent reflector lamps, fluorescent and high-intensity discharge [HID] lamps and ballasts, as well as HID luminaires), and it is expected that future rulemakings would have the effect of accelerating the transition to SSL by making lower performing traditional lighting products obsolete through regulation. Although the annual installation of residential LED bulbs increased six-fold from 13 million to 78 million between 2012 and 2014 (there were fewer than 400,000 installations in 2009), LED bulbs account for only 3 percent of the installed base of indoor lighting and 14 percent of outdoor lighting. However, the installed base of outdoor lighting is

¹ Effective July 1, 2015, the institution is called the National Academies of Sciences, Engineering, and Medicine. References in this report to the National Research Council are used in an historical context identifying programs prior to July 1.

only 5 percent of that for indoor lighting. There remains a great deal of interest in OLED-based lighting because of the diffuse quality of light (compared to LEDs as directional, “point-sources”) and the possibility of integration with flexible substrates, allowing a variety of form factors for OLED lighting.

Truly widespread consumer acceptance of this technology will require products to consistently deliver high-quality light and meet consumer expectations regarding reliability and interoperability with control systems. The determinants of light quality have been continually under re-evaluation; however, essential elements include color quality (chromaticity and color rendering), light intensity, and visual comfort, relating to factors such as the absence of glare, flicker, and disruptive shadows. Expectations for color quality and light intensity are highly context dependent, yet consumers have expectations of equal or better performance of SSL technology compared to legacy lamps and luminaires. Users expect smooth, flicker-free dimming and, in some applications, a warmer color appearance as the lamps dim. However, some newer SSL applications, such as agricultural lighting, require quality parameters that are quite different from the conventional ones used for illumination.

Designers still have relatively little knowledge and information about power supplies or drivers, relying on the luminaire manufacturers for compatibility coordination with the specified control systems. Frustration over the lack of driver standards and choices is evident. Despite the increased penetration of SSL into the commercial sector, there remains a need to educate consumers so that they are aware of the advantages of these new bulbs. **The committee recommends that the Department of Energy, in partnership with industry, states, and utilities, should develop and implement a public outreach program in support of deployment of SSL.** (Recommendation 2-1)

LIGHTING EFFICACY AND PROGRESS IN SSL TECHNOLOGY

Widespread adoption of LED products has the potential to result in a 40 percent savings in the energy consumed by lighting by 2030, relative to the use of other lighting technologies, but these projections are contingent on technology developments that achieve the DOE goal of 200 lumens per watt (lm/W) luminaire efficacy by 2025. In fact, values of 200 lm/W for LED luminaires have already been achieved in the laboratory. To make further progress at the level of luminaires and lighting systems, some fundamental core technological challenges must be addressed. LEDs continue to suffer from the droop in efficiency at high operating currents, as well as the lower efficiency of green LEDs (the so-called “green gap” that makes certain white-light architectures requiring the presence of green light infeasible). Although there is a better understanding of the underlying mechanisms and possible solutions, the costs of implement-

ing those solutions may be too expensive for industry to consider action. Similarly, efficient light extraction and the reduced lifetime of blue OLED emitters remain key technological issues for OLEDs, although there is enough basic understanding of these issues to make progress in these areas. **The committee recommends that DOE should continue to make investments in core technology improvements for SSL technologies, both LED and OLED, and should also consider solutions that will ultimately allow low-cost implementation and embody risks that industry is not likely to take. Early-stage investment in disruptive technologies represents high risks that industry is not likely to take.** (Recommendation 3-1)

MANUFACTURING AND COST

There has been a considerable decrease in the price of LEDs and an increase in their quality—the result of about a 90 percent product cost reduction since 2008 (see Figure S.1). Nonetheless, LEDs are still, and probably will remain, more expensive than incandescent lighting technology. *Thus, cost is still a determinant of the continued penetration of LED SSL and the eventual success of OLED SSL.* Cost-effective approaches may lie in improvements in the manufacturing processes, as well as in the development of SSL within new integrated applications. For example, packaging LEDs in larger packages, such as “chips on board,” makes use of lowered die costs and produces an effective increase in light output. Somewhat ironically, improvements in LED manufacturing processes since the 2013 NRC report, resulting in the drop of component prices and thus profits, have caused some manufacturers to leave the business. This trend, in turn, provides a negative incentive to address the challenge of further improving SSL performance metrics, such as efficacy.

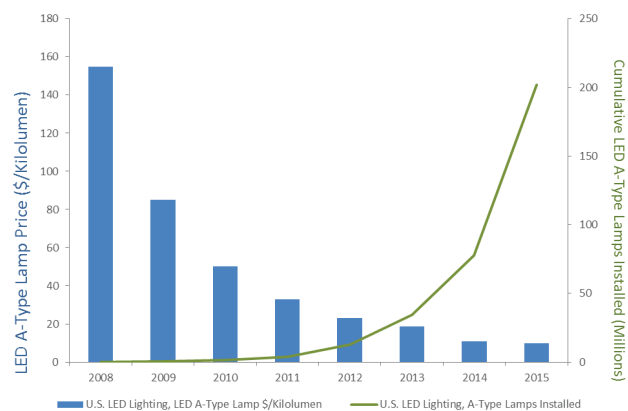

FIGURE S.1 Light-emitting diode (LED) lighting costs. NOTE: Kilolumen is a measure of visible light output by a source. Price data are in nominal dollars as reported in internal tracking report. Cumulative LED A-type bulb installations as reported in market report.

APPLICATIONS AND SYSTEMS

Product designers, as well as lighting designers, are exploring new ways of using SSL products in innovative, dynamic lighting designs, which include features such as changeable spatial distribution of emitted light, spectral tuning, intensity variation, and schedule programming. The development of connected lighting systems, also referred to as “smart lighting,” has also been facilitated by SSL. These systems collect and process data from the illuminated environment and offer additional features to consumers and end users. One example is visible light communication, which can provide local high-speed communications, thus increasing the functionality of lighting that is also used for illumination. *Thus, the committee notes with interest the development of new, feature-rich products that provide additional benefits with functions beyond illumination and that may promise higher margins and higher penetration opportunities for products made by U.S. manufacturers.*

Lighting can be used for other purposes, some of which are becoming more widespread. Strictly speaking, some of these applications, such as visible light communication, are unlikely to reduce energy consumption and have the potential to do the opposite. However, if growth of these applications is inevitable, DOE may wish to consider ways of maximizing efficiency. DOE does set targets for light utilization for advanced luminaire systems in its research and development program, but its approach is still product-focused. **The committee recommends that DOE should develop strategies for supporting broader research that enables more efficient use of light in such a way that the application efficacy is maximized, with attention to both the lighting design process and the design of lighting products.** (Recommendation 4-3)

LIGHTING PROGRAM OF THE U.S. DEPARTMENT OF ENERGY

DOE received \$24 million in its fiscal year 2016 appropriation for lighting programs focusing on improvements in energy efficiency and light quality. Forty-one percent of the funding is for multiyear R&D programs. The funding is split approximately 2:1 between LEDs and OLEDs over the multiyear duration of the programs.

Since DOE began funding SSL research in December 2000, more than 230 cost-shared R&D-funded projects have resulted in more than 245 patents. Recently, commercial SSL products (i.e., luminaires) have efficacies as high as 125 to 135 lm/W and laboratory demonstrations reaching 200 lm/W. Thus, DOE’s goal of having 200 lumen/W for LEDs available by 2025 has already been demonstrated in the laboratory. **The committee recommends that DOE continue investments in cost-effective solutions at 200 lm/W at the luminaire level, while also considering reliability and quality of light. Quality of light needs to be defined with the help of all relevant stakeholders, including—but not necessarily limited to—regulators, manufacturers, efficiency advocates, and consumer advocates.** (Recommendation 2-2)

The lighting industry is very much aware of the market pressures and requirements for products with good lighting quality, in addition to high luminous efficacy. The various stakeholders (regulators, industry, academics, and the Illuminating Engineering Society [IES]) all agree that color rendering, minimal flicker, the ability to dim the lights, and choice of color temperature are elements of good lighting quality, but the exact requirements for these performance features have not been agreed upon. The measurement of color rendering remains controversial, and several alternative metrics have been proposed. The IES has recently published a new color rendering metric, typically referred to by its document number, TM-30 (IES, 2015). There is some, albeit limited, research on the effects of light source spectrum on circadian rhythms and ecological consequences of certain wavelengths during periods of darkness. Evidence on the effects of duration, wavelengths, and intensity is still being researched, while broad assumptions on these effects are already being addressed in voluntary standards. Some research may be needed in order to achieve consensus in these areas.

REFERENCES

- IES (Illuminating Engineering Society). 2015. *Method for Evaluating Light Source Color Rendition*. TM-30-15. New York. <https://www.ies.org/store/product/ies-method-for-evaluating-light-source-color-rendition-3368.cfm>.
- NRC (National Research Council). 2013. *Assessment of Advanced Solid-State Lighting*. Washington, D.C.: The National Academies Press.

1

Introduction

CONTEXT

In 2014, approximately 15 percent of all retail electricity used in the United States was consumed by lighting (EIA, 2016). Since that time, the commercialization of lighting products utilizing light-emitting diodes (LEDs) has grown dramatically. Projections suggest that LED products will account for 48 percent of lighting sales in 2020 and 84 percent of sales in 2030 (based on the light output over product life) (Navigant, 2014), with lighting expected to consume 14 percent of electricity in 2020 and 11 percent in 2030.¹ However, only 6.4 percent of U.S. general illumination, measured in number of installations, was provided by LEDs in 2015 (DOE, 2016).

Widespread adoption of LED products has the potential to result in a 40 percent savings in the energy consumed by lighting by 2030 (Navigant, 2014), relative to the use of other lighting technologies, but these projections are contingent on technology developments that achieve the Department of Energy (DOE) goal of 200 lumens per watt (lm/W) luminaire efficacy by 2025 (DOE, 2016). The 2013 report *Assessment of Advanced Solid-State Lighting* (NRC, 2013) provided two estimates of savings in electricity consumption. In the first estimate, based on the lamp efficacy standards in the Energy Independence and Security Act (EISA) of 2007, Section 321, electricity consumption for lighting could be reduced by 514 terawatt hours (TWh) in the residential sector and 60 TWh in commercial applications, cumulative from 2012 to 2020. In the second estimate, based on more aggressive assumptions about improvements in the efficacies of LED luminaires, the cumulative savings over the same time period were 939 TWh in the residential sector and 771 TWh in the commercial sector. A number of technical challenges must be overcome

to reach these efficacy targets. Furthermore, widespread consumer acceptance of this technology will require products to consistently deliver high-quality light and meet consumer expectations regarding reliability and interoperability with control systems.

STUDY ORIGIN

As required by EISA 2007, DOE engaged the National Research Council² (NRC) to conduct a study of the status of solid-state lighting (SSL), resulting in *Assessment of Advanced Solid-State Lighting* (NRC, 2013). The legislation also includes a requirement for a follow-up report to update the findings of the initial study. The statement of task (Box 1.1) for the second phase of this study involves three main topics: an assessment of the commercialization of SSL, considerations of improvements to current technology, and an evaluation of SSL manufacturing. The primary tasks for the study were to provide the following:

- An assessment of market trends for light-emitting diodes (LEDs) and organic light-emitting diodes (OLEDs).
- An evaluation of the extent of problems with lighting quality, durability, power quality, and integration with controls, as well as recommended improvements.
- A discussion of advancements of LEDs and OLEDs that could increase the number of suitable applications for these technologies.
- An assessment of the ways in which the activities of DOE's Solid-State Lighting Program can contribute to improvements in SSL technologies.
- Comments on the challenges of high-volume, low-cost manufacturing of SSL devices.

¹ Data compiled from the "Residential Sector Key Indicators and Consumption" table and the "Commercial Sector Key Indicators and Consumption" table—both in the Reference Case (Energy Information Administration [EIA], "Total Energy: Production: Crude Oil and Lease Condensate," <http://www.eia.gov/forecasts/aeo/data/browser/>, accessed August 12, 2016).

² Effective July 1, 2015, the institution is called the National Academies of Sciences, Engineering, and Medicine. References in this report to the National Research Council are used in an historical context identifying programs prior to July 1.

- An evaluation of domestic and foreign manufacturing supply chains of LEDs and OLEDs, as well as suggestions for leveraging investments.
- A consideration of countries that dominate particular aspects of the manufacturing supply chain and identification of opportunities for U.S. industry.

BOX 1.1 Statement of Task

The National Research Council (NRC) will appoint a committee to carry out this study and provide a report on the status of advanced solid-state lighting (SSL). The report will update the findings of the 2013 NRC study. Specifically, the committee will focus on the following overarching tasks.

1. *Commercialization of Solid-State Lighting.* The committee will assess the market trends for LEDs and OLEDs including sales volume of different applications and the cost and performance of the luminaire and its components. The committee will evaluate to what extent problems are being encountered with lighting quality (color shift, lumen depreciation, etc.); durability; power factor and generation of harmonics; and integration with controls (e.g., dimmer switches) and will recommend improvements.
2. *Improvements to Current Technology.* The committee will consider advancements that could occur in LEDs, especially in OLEDs, as an increasing number of applications are being pursued and larger volumes are being deployed. The committee will assess how the R&D and other activities supported by DOE's Solid-State Lighting Program can contribute to improvements such as greater efficacies of up to 250 lpw.
3. *Manufacturing.* The committee will comment on the challenges related to high-volume, low-cost manufacturing of SSLs. The committee will evaluate the domestic and foreign manufacturing supply chains (raw materials, epitaxy, wafer and chip manufacture, packaging, device assembly, etc.) for LEDs and for OLEDs, as well as the supporting research and investment infrastructure. Looking at the supply chain in particular, the committee will consider which countries dominate particular aspects of the chain (e.g., China and epitaxy) and will identify opportunities for the U.S. industry and possible leveraging investments by the DOE Solid-State Lighting Program.

The committee will provide a report to the U.S. Department of Energy, the Committee on Energy and Commerce of the House of Representatives, and the Committee on Energy and Natural Resources of the Senate.

To respond to these tasks, the National Academies of Sciences, Engineering, and Medicine established the Committee on Assessment of Solid-State Lighting, Phase 2, composed of diverse experts in the fields of SSL, electronics, lighting design, human perception of light, industry commercialization, and policy (committee biographical information is provided in Appendix A). While conducting this study, the committee members relied on their own expertise, information from publications they judged to be of high quality, and many interactions with experts in the field (Appendix B).

The committee addresses Item 1 of the statement of task, commercialization, in Chapter 2, noting the large changes in the cost and deployment volume of SSL in the past few years. Item 2, improvements to current technology, is discussed in Chapters 3 and 4, which update the findings of the 2013 report to include the latest status of LED- and OLED-based SSL devices and luminaires. The committee addresses Item 3, manufacturing, in Chapter 5, a focus that is new since the 2013 report, when the manufacturing of SSL was in a nascent stage.

INTRODUCTION TO LIGHTING

As in many technical fields, terminology used by lighting experts can differ from common language. A discussion of lighting hardware, metrics for measuring light, color quality, and lighting technologies was provided in the earlier report (NRC, 2013), and this background information is provided in Appendix C. The increased prevalence of LED lighting products has led to some subtle changes in the use and meanings of some terms used to describe light hardware. For instance, the designation for MR16 lamps technically refers to lamps with 2-inch-diameter multifaceted mirror reflectors. However, many LED replacement "MR16" lamps do not include reflectors at all. Instead, the LED packages and optical elements of the lamps are designed to produce a similar distribution of light to true MR16 halogen lamps.

Light Intensity and Efficacy

As described in Appendix C, the primary measure of the amount of light emitted from a lamp (light bulb) or luminaire (light fixture) is luminous flux, which has the unit of lumen (lm). Luminous flux is a measure of the optical power emitted from a light source, weighted by the sensitivity of the human visual system. Since the human visual system is not equally sensitive to all wavelengths of light, the spectral power distribution (the relative amount of light per wavelength) of light generated impacts luminous flux. The luminous flux of a lamp is most closely related to its total light output as perceived by the human visual system. Luminous efficacy, which has a unit of lumens per watt (lm/W), is the luminous flux emitted by a lighting product per watt of electrical power consumed. Luminous efficacy is a measure of the energy efficiency of a lamp or luminaire. A high value indicates an

energy-efficient lighting product, and a low value suggests that a lamp or luminaire is relatively inefficient. Generally, the luminous efficacy of lamps and luminaires cannot be directly compared. Lamps are typically placed within luminaires during operation, where some of the emitted light is lost to absorption. For instance, the efficacy of fluorescent tubes can exceed 100 lm/W, but in the fluorescent fixture can lead to an average loss of 26 percent of the light (PNNL, undated).

Light Color Properties

There are two primary color properties of a light source: chromaticity and color rendering. Chromaticity is a description of the appearance of the color of the light when viewed directly. There are several ways to quantify and communicate chromaticity. For white light sources, correlated color temperature (CCT), which is an indication of the temperature of a blackbody radiator that produces a light that appears most similar in color, is most commonly used. White lights with a reddish tint, which are often described as appearing “warm,” tend to have CCTs of approximately 2,500 K to 3,500 K. Neutral white light often has a CCT of approximately 3,500 K to 4,500 K. White lights with a bluish tint, often described as appearing “cool,” commonly have CCTs of approximately 4,500 K to 6,500 K. Because CCT describes the yellowishness/bluishness of nominally white light sources, a supplementary descriptor of the greenishness/reddishness is useful. This measure, Duv, is a signed quantity of the difference between the chromaticity of the light and the chromaticity of a blackbody radiator (Ohno, 2014). Positive values indicate greenish chromaticities, and negative values indicate reddish chromaticities. While chromaticity describes the color appearance of the light, color rendering refers to the color appearance of objects illuminated by the light source. A common measure of the color rendering characteristics of a light source is the color rendering index (CRI) (CIE, 1995). The CRI is calculated by comparing the color appearance of a set of object colors when illuminated by the light source of interest with their color appearance when illuminated by a reference illuminant (blackbody radiator or daylight). A general color rendering index (R_a) of 100 means that the test source renders eight particular object colors identically to the reference illuminant. The measurement of color rendering remains controversial, with many proposed alternative metrics (e.g., Davis and Ohno, 2010; Rea and Freyssinier-Nova, 2008). The Illuminating Engineering Society (IES) has recently published a new color rendering metric (IES, 2015), typically referred to by its document number, TM-30.³

³ TM-30 is “a method for evaluating light source color rendition that takes an objective and statistical approach, quantifying the fidelity (closeness to a reference) and gamut (increase or decrease in chroma) of a light source. The method also generates a color vector graphic that indicates average hue and chroma shifts, and which helps with interpreting the values of R^f

Relationship Between Color and Efficacy

As explained in Appendix C, the spectral power distribution (SPD) of a light source not only determines chromaticity and color rendering, but also has a significant impact on luminous efficacy. Luminous efficacy of radiation (LER) accounts for the visual system’s differential sensitivity to different wavelengths of light and represents the theoretical maximum luminous efficacy, as illustrated in Figure C.9 in Appendix C. The sensitivity of the human visual system is maximal for light of 555 nm (green), which has an LER of 683 lm/W, and is lower for shorter (bluer) and longer (redder) wavelengths.⁴ The actual luminous efficacy of a lighting product is dependent on both the LER and the efficiency with which the technology converts electricity to light (radiant efficiency). The LER of a light source can be maximized for a given chromaticity and general color rendering index (R_a). For instance, the SPDs shown in Figure 1.1 were optimized for maximum LER for six different CCTs, with the following restrictions: Duv = 0.0, CRI R_a = 80, and each SPD consists of only four individual wavelengths of light (similar to the spectral power from four lasers). As can be seen, with these restrictions, SPDs with lower CCTs can achieve higher LERs than higher CCTs. Currently, cool white (high-CCT) LEDs have higher luminous efficacies than warm white (low-CCT) LEDs (DOE, 2015). This is simply a consequence of differences in radiant efficiency—it is not due to differences in the sensitivity of the human visual system.

FINDING: Warm white light is not inherently less efficacious than cool white light. The development of long-wavelength (red) emitters with high radiant efficiency would enable the production of high-efficacy warm white SSL products. DOE is currently prioritizing the development of high-efficiency, high-flux red LEDs and high-efficiency red down-converters (DOE, 2016).

Color rendering and LER are generally inversely related. Figure 1.2 shows the maximum LER as a function of R_a for SPDs consisting of four wavelengths of spectral power, with CCT = 3,000 K and Duv = 0.000. The tension between two variables must be negotiated by lighting manufacturers and lighting designers throughout product development and specification.

Lighting Quality

Lighting designers aim to provide high-quality lighting in the built environment. Although the determinants of light quality are debatable, they are frequently thought to include

and R^g ” (Illuminating Engineering Society of North America [IES], “IES Method for Evaluating Light Source Color Rendition,” <http://www.ies.org/store/product/ies-method-for-evaluating-light-source-color-rendition-3368>, accessed October 4, 2016).

⁴ This is illustrated by Figure C.9 in Appendix C.

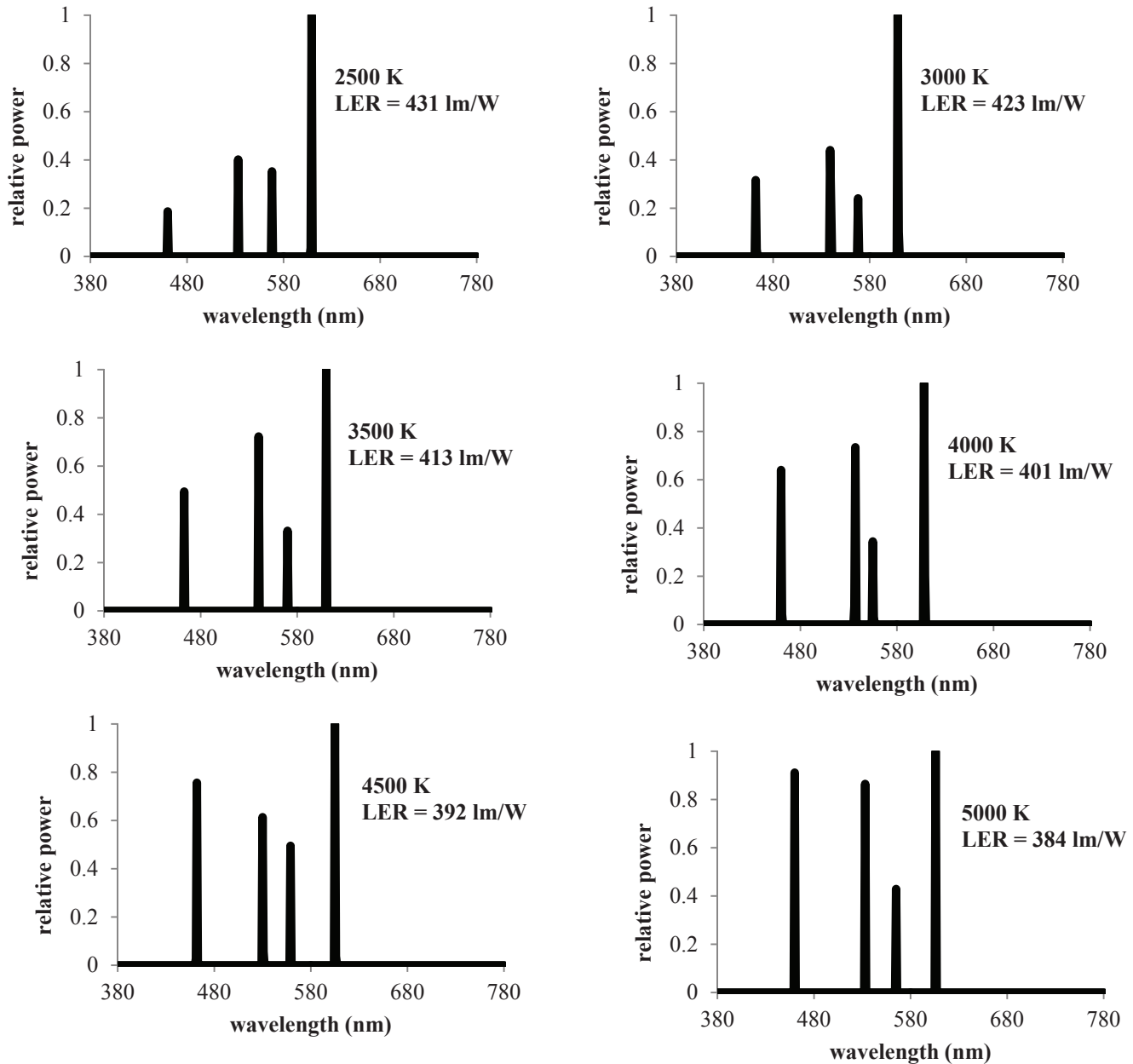

FIGURE 1.1 Maximum luminous efficacy of radiation (LER) for spectral power distributions (SPDs) consisting of four wavelengths of spectral power at six different correlated color temperatures. For all SPDs, $Duv = 0.000$ and color rendering index (R_a) = 80.

color quality (chromaticity and color rendering), light intensity, and visual comfort (IES, 2009). Expectations for color quality and light intensity are highly context dependent. For instance, the optimal intensity of light for a movie theater is very different from that for a health clinic. In a movie theater, the lighting must be quite dim, so as to not interfere with the appearance of the projected image. In a health clinic, the intensity of the light must be higher to allow the practitioners to examine patients, maintain cleanliness, and

perform clerical work. Similarly, judgments of chromaticity quality are often quite different when considering fine dining restaurants or corporate offices. Visual comfort is frequently defined as the absence of glare, flicker, and disruptive shadows (IES, 2009). Judgments of quality are also applied to lighting products and are frequently dependent on expectations. Consumers, such as homeowners or facilities managers, purchasing retrofit lamps typically expect the lamps to behave and perform identically to the replaced product. They

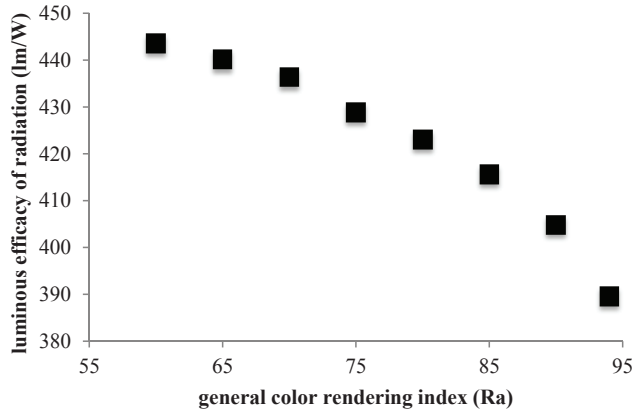

FIGURE 1.2 Maximum luminous efficacy of radiation as a function of general color rendering index (R_a) for spectral power distribution consisting of four wavelengths of spectral power, with correlated color temperature = 3,000 K and $Duv = 0.000$.

expect the same chromaticity, color rendering, luminous flux, spatial distribution of emitted light, and interoperability with control systems. They may also consider product consistency, purchase price, efficacy, and lifetime when judging product quality. Professional lighting designers also consider these factors but have specialized knowledge and understand the metrics that characterize the attributes of the products. Rather than expecting all lighting products to behave identically, professionals expect them to perform according to their specifications and judge quality accordingly.

Average or typical prices of lighting products can be expressed in a number of ways. When considering a type of technology or product category, the price per kilolumen (\$/klm) can be useful. When using this metric for low luminous flux (<1,000 lm) product types, the value represents the price for more than one product. When applied to higher luminous flux (>1,000 lx) product types, this measure communicates the price of less than one product. Sometimes, the price per kilolumen-hour (\$/klm-h) is used, which takes expected product lifetime into account.

ELECTRICITY CONSUMED BY LIGHTING IN THE UNITED STATES

The most recent estimates of electricity consumed by lighting in the United States were developed by the Energy Information Administration (EIA). Commercial lighting, including street and highway lighting, was estimated to consume 262 TWh in 2014, accounting for 19 percent of the electricity consumed by commercial and institutional buildings (EIA, 2015). Residential lighting consumed an estimated 150 TWh that same year, representing 14 percent of residential consumption of electricity (EIA, 2015). The

combined electricity consumption of 412 TWh from both sectors in 2014 was a reduction of approximately 17 percent from their estimated consumption of 499 TWh in 2010 (EIA, 2011), the data considered in the 2013 NRC report. Data on the electricity consumed by lighting for manufacturing are less recent, with an estimated consumption of 52 TWh in 2010, a 17 percent reduction from the 63 TWh consumed in 2006.⁵

Projections predict a 57 percent reduction in the energy consumed by lighting in the United States in 2040, relative to consumption in 2013 (EIA, 2015). Increases in the utilization of electric light and efficiency rebound effects, whereby increases in energy efficiency are offset by reductions in energy conserving behaviors of users, are accounted for in this projection, but increases in the efficacy of lighting products used are expected to lead to a reduction of lighting energy consumption by an average of 3.1 percent per year in the residential sector and by an average of 0.6 percent in the commercial sector until 2040 (EIA, 2015).

OVERVIEW OF LED APPLICATION TYPES

By the end of the 2014, the number of LED products installed in the United States had quadrupled since 2012 (Navigant, 2014), the time at which the 2013 NRC study on SSL was being conducted. Although LEDs reached only 3 percent market penetration for general illumination applications in the United States in 2014 (Navigant, 2014), this technology was already dominating some niche applications, including traffic signaling, exit signage, flashlights, and refrigerator case lighting (Navigant, 2014). Small directional lamps, largely consisting of MR16 replacements, achieved the greatest general lighting market penetration in 2014, representing 21.8 percent of the installed base (10.3 million units) (Navigant, 2014). Medium screw-base lamps, which serve as direct replacements for many standard incandescent lamps, had the largest number of installed units (77.7 million) at that time. However, because the number of medium screw sockets is so large, this only represents 2.4 percent market penetration (Navigant, 2014). Market penetration of other directional lighting products, including downlight luminaires and larger directional lamps, was 5.8 percent (67 million units). Other interior applications include decorative lamps (1.5 percent penetration; 67 million units), linear luminaires (including those using replacement lamps: 1.3 percent penetration; 12.5 million units), and low/high bay luminaires (2.2 percent penetration; 3.1 million units). Overall, LEDs penetrated 2.8 percent of the indoor illumination market in 2014, with 188 million units installed. At that time, LEDs were installed in 10.1 percent of exterior illumination applications (17.9 million products). LED products have been

⁵ EIA, "2010 Manufacturing Energy Consumption Survey Data," <https://www.eia.gov/consumption/manufacturing/data/2010/#r5>, accessed August 8, 2016.

used in outdoor lighting applications longer than indoor applications, because of the promise of a long life with subsequent reduced maintenance. In outdoor applications, LEDs achieved greatest market penetration with area/roadway luminaires (12.7 percent market penetration; 5.7 million installed units) and lamps and luminaires to illuminate the exterior of buildings (11.5 percent market penetration; 7.6 million installed units). LEDs were used less frequently to illuminate parking lots (9.7 percent market penetration; 2.8 million units) and parking garages (5.0 percent market penetration; 1.8 million units). LEDs were installed in 3.3 percent (8.3 million units) of other illumination applications, such as wall washing, cove lighting, stadium lighting, and tunnel lighting (Navigant, 2014).

Early reports suggest that market penetration increased substantially in 2015, accounting for 6.4 percent (473 million units) of the general illumination installed base (DOE, 2016). Small directional lamps continued to have the greatest proportion of market penetration at 32.1 percent (16.3 million units), and medium screw-base lamps had the greatest number of installed units at 202 million (6.0 percent market penetration). Market penetration for other interior applications was 11 percent (127 million units) for other directional lights, 3.0 percent (36.9 million products) for decorative lamps, 3.2 percent (31.5 million units) for linear fixtures, and 3.7 percent (5.4 million) for low/high bay luminaires, resulting in a total LED market penetration of 6.1 percent (419 million units) for interior applications. For exterior applications, the greatest increase in market penetration was for building exterior lights (21.2 percent; 14.7 million installed units) in 2015. Market penetration for other exterior applications was 20 percent (9.1 million units) for area and roadway luminaires, 13.0 percent (5.0 million products) for parking garage lights, and 13.9 percent (4.0 million) for parking lot lights, resulting in a total LED market penetration of 17.9 percent (32.7 million units) for exterior applications. LEDs were installed in 8.0 percent (21.4 million units) of other lighting applications (DOE, 2016).

FINDING: LED-based lighting products account for a rather small portion (6.4 percent in 2015) of installed base of general illumination products in the United States. However, market penetration is accelerating and more than doubled from 2014 to 2015.

The luminous efficacy of LED products is variable both within and between each product category. Interestingly, MR16 lamps, which achieved the greatest market penetration in 2014, had a lower average efficacy, 58 lm/W (highest efficacy of 95 lm/W), than other LED product types listed in the Lighting Facts database.⁶ Although the consumer

decision-making process driving this adoption has not been studied, one potential reason for strong uptake of this lamp type is the relatively low luminous efficacy of alternate technologies (EIA, 2016). The characteristics of MR16 lamps are very difficult to achieve with fluorescent solutions, so halogen technology is still widely used. Another possible reason for their strong adoption is the relative ease with which LEDs can create small, directional lights (Jordan et al., 1996), such as MR16 lamps. Other directional lamps (average efficacy of 63 lm/W; highest efficacy of 111 lm/W) and luminaires (average efficacy of 63 lm/W; highest efficacy of 124 lm/W) had slightly higher typical efficacies, as did decorative lamps (average efficacy of 66 lm/W; highest efficacy of 90 lm/W) and medium screw-base lamps (average efficacy of 72 lm/W; highest efficacy of 107 lm/W). Linear replacement lamps (average efficacy of 108 lm/W; highest efficacy of 148 lm/W), linear luminaires (average efficacy of 93 lm/W; highest efficacy of 139 lm/W), and low/high bay luminaires (average efficacy of 97 lm/W; highest efficacy of 141 lm/W) were more efficacious, possibly because the incumbent technologies (linear fluorescent lamps and high-intensity discharge lamps) for these applications have quite high luminous efficacies. For outdoor applications, the least efficacious products were used to illuminate the exterior of buildings (average efficacy of 77 lm/W; highest efficacy of 132 lm/W). Replacement lamps for parking garages had rather high luminous efficacies (average efficacy of 108 lm/W; highest efficacy of 158 lm/W). Area/roadway lights (average efficacy of 87 lm/W; highest efficacy of 137 lm/W), parking lot luminaires (average efficacy of 87 lm/W; highest efficacy of 137 lm/W), and parking garage luminaires (average efficacy of 86 lm/W; highest efficacy of 150 lm/W) performed similarly to each other.

Although the purchase price of LED products remains more expensive than alternative technologies, the prices of LED products and components have decreased significantly since the 2013 NRC report (DOE, 2016). The price of LED packages was as low as \$1/klm at the end of 2014, while OLED panels were priced at \$200/klm. The typical purchase price of a warm white, dimmable medium screw-base replacement LED lamp was \$10/klm in 2015, on a par with \$10/klm for a dimmable CFL and compared to \$2.50/klm for a halogen lamp. The purchase price of a warm white 2' × 4' linear luminaire was \$29/klm, compared with \$4/klm for a linear fluorescent luminaire. LED roadway luminaires cost \$58/klm at the end of 2014, and competing technologies were priced at \$1.2/klm to \$2.1/klm. Also in 2014, LED MR16 replacements were priced at \$40/klm at that time, whereas halogen MR16 lamps were \$11/klm (DOE, 2015). Prices of LED products continue to decrease rapidly. Although commercially available OLED luminaires are rare, a typical price for 2015 was estimated to be \$870/klm, based

⁶ For further information, see the LED Lighting Facts website at <http://www.lightingfacts.com/Products>.

on one luminaire available to consumers in the United States (DOE, 2016).⁷

LED products are replacing incandescent lamps, presumably, at least in part, because the Energy Independence and Security Act of 2007 (P.L.110-14) reduced the availability of that technology beginning in 2012. However, LEDs also appear to be replacing other lighting technologies. Despite the phasing out of the traditional incandescent lamps, shipments of compact fluorescent lamps (CFLs) have decreased (NEMA, 2015). Market penetration of CFLs decreased from 2012 to 2014 for decorative lamps and directional lighting products (EIA, 2016). Furthermore, some of the applications in which LEDs are penetrating do not typically use incandescent technology. For instance, roadway lighting had traditionally been achieved with high-intensity discharge technologies.

Manufacturers of LED products have adopted different strategies in the integration of LED packages in lamps and luminaires. While many manufacturers directly install LED packages in their lighting products, some are using LED modules or LED light engines.⁸ In 2014, 33 percent of LED luminaires and 12 percent of LED lamps utilized LED modules, while 9 percent of LED luminaires and 1 percent of LED lamps used LED light engines.⁹

The 2013 NRC report warned of the potential for unintended consequences, including the possibility that increased application of electric lighting solutions would negate the increased efficacy of SSL, leading to an increase in the energy consumed by lighting (NRC, 2013). While the market penetration of LEDs is still too small to determine whether this situation will arise, the decrease in total electricity consumed by lighting in the United States between 2010 and 2014 (EIA, 2011, 2015), discussed in the section, “Electricity Consumed by Lighting in the United States,” suggests that the adoption of more energy-efficient lighting technologies and the benefits of reduced electricity it confers is not being cancelled out by the rebound effect that can occur when lower electricity prices lead to increased consumption. However, as LEDs have some desirable characteristics that other high-efficacy technologies do not have, such as very small size, excellent performance in cold temperatures, and robustness, this issue has not yet been settled. The 2013 report also noted that many commercialized LED products had lower luminous flux than the light sources they were designed to replace. This situation has improved in the past few years, but the luminous flux of replacement and retrofit products remains variable. A 2013 analysis of medium screw-base lamps suggests that Energy Star minimum luminous flux requirements for manufactur-

ers wishing to claim equivalency with incandescent wattage resulted in widespread compliance (DOE, 2013a). A 2016 report found that only approximately 20 percent of LED MR lamps had luminous flux values comparable their 50 W halogen counterparts (DOE, 2013b). These findings suggest that some types of LED products are not performing equivalently to the technologies they are replacing, but that incentive programs offered to consumers to reduce the cost of buying the product can be leveraged to drive consistency.

REFERENCES

- CIE (Commission Internationale de l'Éclairage). 1995. *Method of Measuring and Specifying Colour Rendering Properties of Light Sources*. CIE 13.3. Vienna, Austria.
- Davis, W., and Y. Ohno. 2010. Color quality scale. *Optical Engineering* 49(3):033602.
- DOE (U.S. Department of Energy). 2013a. “Snapshot: Light Bulbs.” http://apps1.eere.energy.gov/buildings/publications/pdfs/ssl/snapshot2013_a-lamp.pdf.
- DOE. 2013b. “Snapshot: MR16 Lamps.” http://energy.gov/sites/prod/files/2016/01/f29/snapshot2016_mr16_0.pdf.
- DOE. 2015. *Solid-State Lighting R&D Plan*. Washington, D.C. May.
- DOE. 2016. *Solid-State Lighting R&D Plan*. Washington, D.C. June.
- EIA (Energy Information Administration). 2011. *Annual Energy Review, 2010*. Washington, D.C.
- EIA. 2015. *Annual Energy Review, 2014*. Washington, D.C.
- EIA. 2016. *Annual Energy Outlook 2016*. Washington, D.C.
- Holzman, H.N. 1999. Branch circuits and feeders. Chapter 12 in *Modern Commercial Wiring*. Tinley Park, Ill.: Goodheart-Willcox.
- IES (Illuminating Engineering Society of North America). 2009. *Light + Design: A Guide to Designing Quality Lighting for People and Buildings*. IES DG18-08. New York.
- IES. 2015. *IES Method for Evaluating Light Source Color Rendition*. TM-30-15. New York.
- Jordan, R.H., A. Dodabalapur, and R.E. Slusher. 1996. Efficiency enhancement of microcavity organic light emitting diodes. *Applied Physics Letters* 69(14):1997-1999.
- Navigant Consulting, Inc. 2014. *Energy Savings Forecast of Solid-State Lighting in General Illumination Applications*. Prepared by Navigant Consulting, Inc., for the U.S. Department of Energy, Office of Energy Efficiency and Renewable Energy, Building Technologies Program. August.
- NEMA (National Electrical Manufacturers Association). 2015. *Lamp Indices: Compact Fluorescent Lamp Shipments Continue to Lag*. January 20. <http://www.nema.org/news/Pages/Compact-Fluorescent-Lamp-Shipments-Continue-to-Lag.aspx>.
- NRC (National Research Council). 2013. *Assessment of Advanced Solid-State Lighting*. Washington, D.C.: The National Academies Press.
- Ohno, Y. 2014. Practical use and calculation of CCT and Duv. *Leukos* 10(1):47-55.
- PNNL (Pacific Northwest National Laboratory). *Performance of T12 and T8 Fluorescent Lamps and Troffers and LED Linear Replacement Lamps*. Prepared for the U.S. Department of Energy by PNNL.
- Rea, M.S., and J.P. Freyssinier-Nova. 2008. Color rendering: A tale of two metrics. *Color Research and Application* 33(3):192-202.

⁷ Based on Acuity Brands Luminaires’ Chalina 5-Panel Brushed Nickel OLED Pendant available at Home Depot.

⁸ LED modules cannot be directly connected to branch circuits, whereas LED light engines can (Holzman, 1999).

⁹ Stephanie Pruitt, Strategies Unlimited, “Lighting and LEDs Market Overview and Forecast,” presentation to the committee on November 11, 2015.

2

Public Policy and Deployment of New Lighting Technologies

INTRODUCTION

This chapter discusses the commercialization of solid-state lighting (SSL) as well as government programs that support or hinder that objective. Chapter 1 provided an overview of current light-emitting diode (LED) application types and the current sales and efficiency of the products. This chapter provides a discussion of LED lighting markets, the present and potential, as well as public policy that affects commercialization, including a discussion about the Solid-State Lighting Program at the Department of Energy (DOE), legislation, regulation, voluntary programs and procurement programs by federal and/or state governments, industry voluntary programs, as well as development of codes and standards. Finally, there is a brief discussion about public policy outside the United States.

GLOBAL LIGHTING MARKET: STATUS AND POTENTIAL

The penetration of SSL has increased dramatically since the 2013 *Assessment of Advanced Solid-State Lighting* report (NRC, 2013). There remains, however, a large opportunity for SSL products worldwide. Although there has been a considerable decrease in the price of LEDs and an increase in the quality, they are still, and probably always will be, more expensive to purchase than traditional lighting technology. Owing to the higher price, the market share will be larger in terms of revenue generated than number of units sold. Further, the number of replacement lamps that have not been converted to LED will continue to decrease, and at such time the absolute number of units sold may decrease, even though LEDs may dominate on a percentage basis.¹

Strategies Unlimited (DOE, 2015) estimates that in 2014, LED lamps were 5 percent of unit sales, 41 percent of total lighting revenue, and 3 percent penetration of the installed

base. In its 2016 research and development (R&D) plan, *Solid-State Lighting R&D Plan*, DOE reported that the global installed base of LED lamps had risen to 6 percent by the end of 2015 (DOE, 2016a). In 2020, it is projected that LED lamps will be 42 percent of unit sales, 76 percent of revenues, and one-third of the installed base. Major suppliers, including Acuity Brands, OSRAM, Philips, and Zumtobel report that LED products now account for over 40 percent of total revenues. For 2014, LED Inside has estimated that for the global industry as a whole, LED sales were \$20 billion, which is 26 percent of total lighting revenues. Table 2.1 compares several forecasts of global lighting revenues. While the table reveals differences even when comparing similar products, all projections show significant growth in LED market shares ranging from 67 percent to 80 percent by 2022.

The global adoption of LEDs, shown in Figure 2.1, is only just beginning. Strategies Unlimited forecasts that SSL penetration of the global installed base will grow rapidly from less than 5 percent in 2014 to greater than 30 percent by 2020.² As can be seen in Table 2.1, different sources of market data report somewhat different results, but they all indicate a growing market share for LED lighting in lamps and luminaires. Examining the causes for these differences is beyond the scope of this report, but the trends between the different data sources are remarkably similar in terms of year-to-year growth. The global lamp revenue forecast is shown in Figure 2.2 and indicates that the revenues will peak around the year 2020. In contrast, luminaire revenue forecast, shown in Figure 2.3, are projected to grow during this time period at least until 2022.

UNITED STATES FORECASTS

The forecasts of LED adoption in the United States are similar to global forecasts in that LEDs currently account for

¹ When discussing estimates of LED adoption rates, one should distinguish between unit sales, sales revenues, and their installed base.

² Philip Smallwood, presentation at the Strategies in Light Conference, February, Las Vegas, Nev., 2015.

TABLE 2.1 Global Market Share of LED Lighting Measured as a Percentage of Total Lighting Revenue

Source	Scope	2014 (%)	2016 (%)	2018 (%)	2020 (%)	2022 (%)
IHS	Lamps	31	42	52	61	67
Strategies Unlimited	Lamps	41	56	68	76	80
Strategies Unlimited	Luminaires	33	44	53	61	69
LED Inside	Lamps and luminaires	26	34	54	—	—

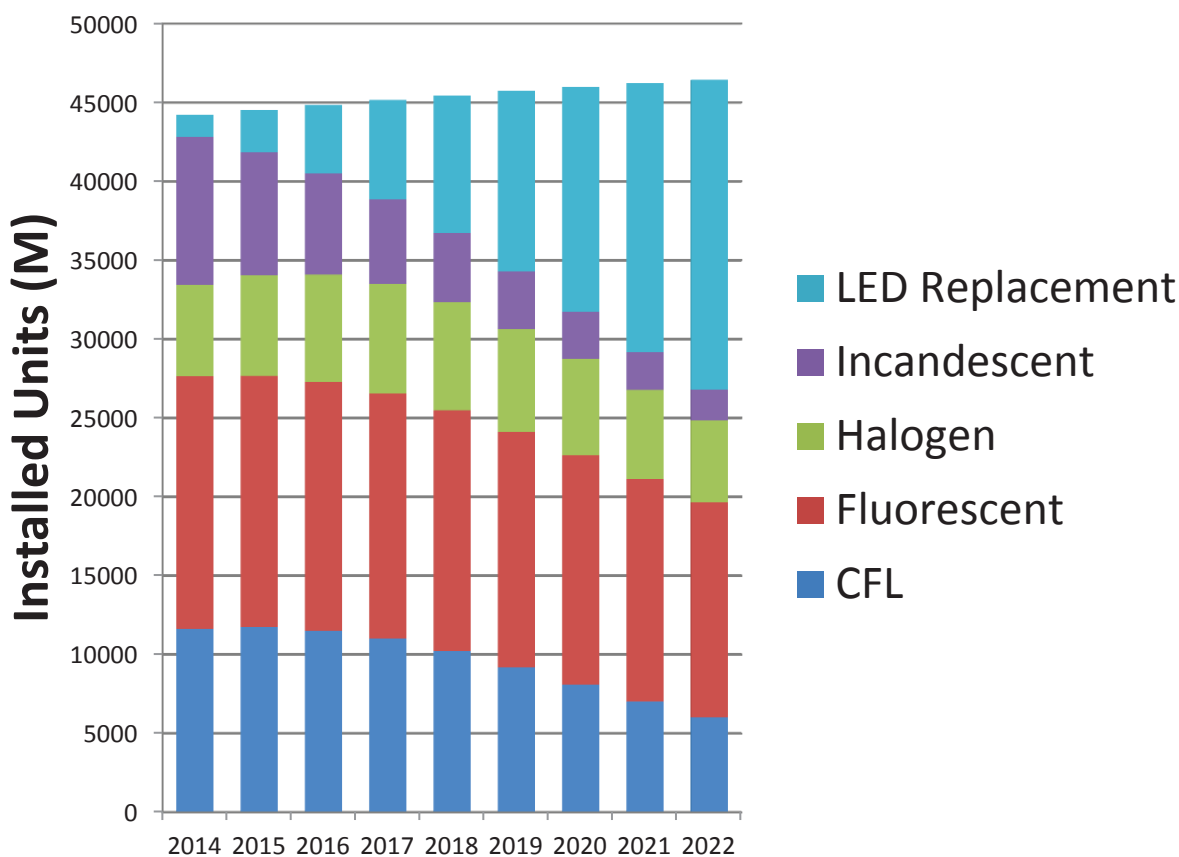

FIGURE 2.1 Evolution of the global installed lamp base (all sectors) by lighting technology. NOTE: CFL = compact fluorescent light; LED = light-emitting diode. SOURCE: Strategies Unlimited, www.strategies-u.com. Reprinted with permission.

a small but increasing share of the lighting market. DOE’s SSL forecasts state that by 2020, SSL should account for nearly half of all lighting shipments in the United States and about 40 percent of the installed base.

Figure 2.4 shows the shifts forecast for lighting technologies from 2013 to 2030. LEDs accounted for less than 4 percent of the installed base (in lumen-hours) in 2014. As can be seen in Figure 2.4, the U.S. installed base is currently dominated by linear fluorescent and high-intensity discharge (HID) lamps, which have a large number of installations, large number of operating hours, and high lumen output per lamp. By 2030, LED light is forecast to account for 88

percent of all lumen-hours for general illumination. This is predicated on continual price decreases and efficiency increases. Table 2.2, taken from the DOE 2016 SSL R&D Plan, shows the doubling of the installed base of LED lighting from 2014 to 2015. A more detailed discussion of the lighting submarkets—directional lighting, decorative, linear fixture, and so forth—can be found in the report *Energy Savings Forecast of Solid-State Lighting in General Illumination Applications* (DOE, 2016b).

Table 2.3 shows forecast U.S. market share in 5-year intervals—2020 through 2035, with 2015 as the base year—of LED lighting shipments in terms of lumen-hours

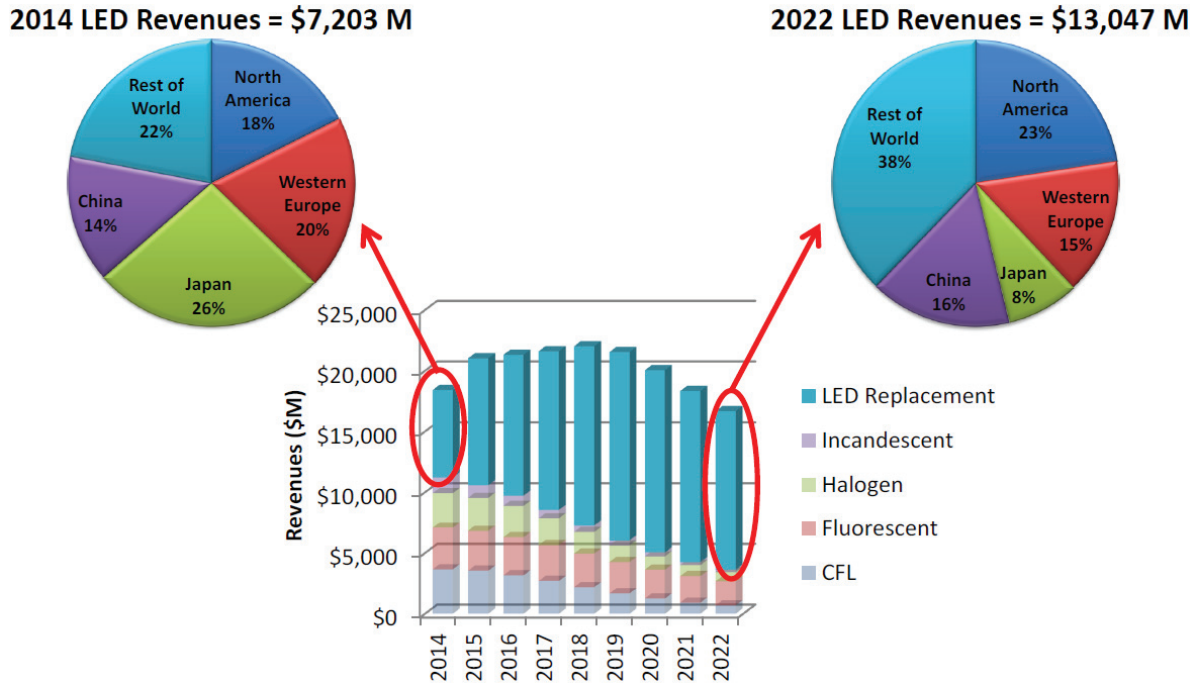

FIGURE 2.2 Global lamp revenue forecast (all sectors). NOTE: CFL, compact fluorescent light; LED, light-emitting diode; M, million. SOURCE: Strategies Unlimited, www.strategies-u.com. Reprinted with permission.

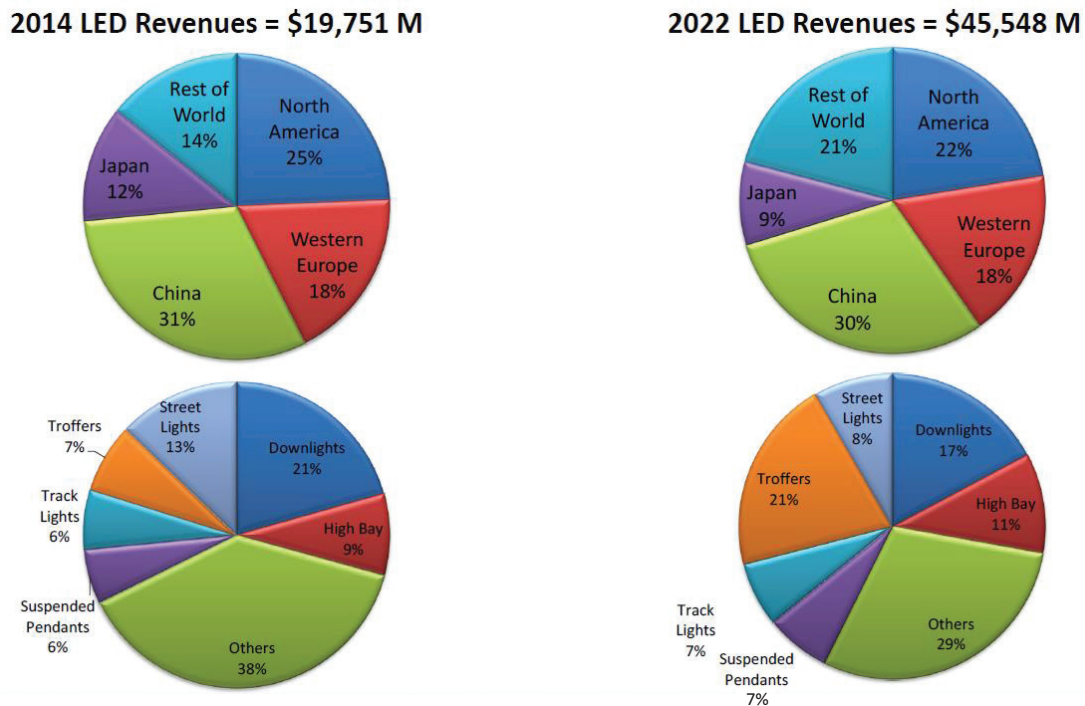

FIGURE 2.3 Global luminaire revenue forecast. NOTE: CFL, compact fluorescent light; LED, light-emitting diode; M, million. SOURCE: Strategies Unlimited, www.strategies-u.com. Reprinted with permission.

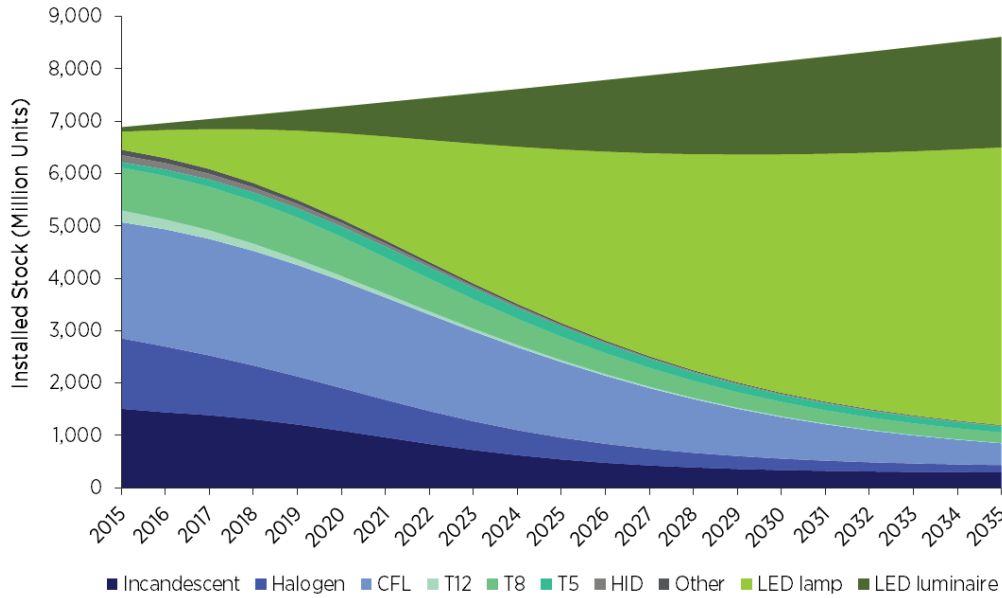

FIGURE 2.4 U.S. lighting service forecast, 2015 to 2035. NOTE: CFL = compact fluorescent light; HID = high-intensity discharge; LED = light-emitting diode. SOURCE: DOE (2016b; p. 17).

TABLE 2.2 LED Installations and Energy Savings by Application

Application ^a	2014 LED Installed Penetration (%)	2015 LED Installed Penetration (%)	2015 LED Units Installed ^b (Millions)	2015 Energy Savings (tBtu)	Estimated Saving Potential ^c (tBtu)
A-Type	2.4	6.0	202	42.7	542
Directional	5.8	11.0	127	55.3	321
Small directional	21.8	32.1	16.3	24.5	34
Decorative	1.5	3.0	36.9	5.0	190
Linear fixture	1.3	3.2	31.5	59.3	1,819
Low/high bay	2.2	3.7	5.4	40.5	1,192
Total indoor	2.8	6.1	419	227	4,097
Area roadway	12.7	20.0	9.1	10.0	210
Parking garage	5.0	13.0	5.0	6.4	140
Parking lot	9.7	13.9	4.0	10.2	253
Building exterior	11.5	21.2	14.7	10.5	71
Total outdoor	10.1	17.9	32.7	37.1	674
Other	3.3	8.0	21.4	13.3	196
Total all ^d	3.0	6.4	473	278	4,967

^a See Appendix 8.1 for definitions of SSL Lighting Applications and products within each category.

^b Installations are the total cumulative number of LED lamps and luminaires that have been installed as of 2014.

^c The estimated savings potential is the theoretical energy savings that would return from switching all lighting fixtures “overnight” in the given application to the best LED product available in the DOE LED Lighting Facts database (in 2015). It is important to note that these “best of” LED products have efficacies much higher than those most commonly available.

^d Values may not add due to rounding.

SOURCE: DOE (2016a).

TABLE 2.3 Forecasted U.S. LED Installed Stock and Market Share of Lighting Shipments by Sector and by Submarket

LED Forecast Stock Results for the Current SSL Path Scenario, ^a by Sector (in lumen-hour)					
Current SSL Path	2015	2020	2025	2030	2035
LED Installed Stock (million units) ^b	424	2,740	5,500	7,040	7,860
Commercial	136	436	826	1,080	1,220
Residential	260	1,610	3,550	5,040	5,970
Industrial	5	19	36	43	44
Outdoor	30	93	137	160	177
LED Installed Stock Penetration (%)	6	30	59	78	86
Commercial	12	36	64	80	86
Residential	5	28	57	77	86
Industrial	8	32	65	78	83
Outdoor	19	57	79	88	93
LED Penetration by Submarket for the Current SSL Path Scenario ^a (in percent)					
Submarket	2015	2020	2025	2030	2035
A-Type	6	29	56	78	90
Decorative	2	27	63	77	82
Directional	11	39	69	82	86
Linear fixture	3	16	47	68	77
Low and high bay	6	38	68	80	86
Parking	17	48	72	84	90
Area and roadway	21	66	91	97	99
Building exterior	21	58	77	85	91
Other ^c	7	39	71	87	93
Total LED Installed Stock Penetration	6	30	59	78	86

^aThe Current SSL Path Scenario assumes current levels of investment and effort from DOE and industry.

^b Installed stock for the DOE SSL Program Goal scenario is not provided as there are negligible differences between scenarios. LED installed stock is presented in terms of lighting systems (lamp(s), ballast, and fixture are counted as one unit).

^c The “other” submarket is included to accommodate lighting products with unknown applications; however, it will not be explored in great detail in this report.

SOURCE: DOE (2016b, pp. 18 and 26).

for nine common lighting applications. This table employs a methodology that has been updated versus previous DOE SSL market analyses (DOE, 2016b; p. 6). The following are some observations from these data:

- As of 2015, LEDs had a much larger market penetration (19 percent) in the outdoor sector than in the indoor sectors (ranging from 5 percent to 12 percent, depending on application). By 2035 both are anticipated to have large penetrations: outdoor (greater than 90 percent); indoor (greater than 80 percent).³

- In 2015, at 21 percent, the area and roadway subsector and building exterior subsector are tied for the highest level for LED penetration. Area and roadway is predicted to be 99 percent by 2030.
- As a result of the early success of small directional MR16 replacement lamps, the directional submarket has the largest penetration of the indoor market sector at 11 percent.
- The projections indicate that LED lighting will make up nearly half of all lighting shipments (48 percent) by 2020 and 86 percent by 2035.

³ DOE found that LED penetration into the installed base was 6.1 percent indoor and 17.9 percent outdoor, using the aforementioned since-updated

methodology (DOE, 2016a, p. 26). There is no comparable number for the indoor penetration in the newer study (DOE, 2016b).

A secondary effect of the LED revolution in lighting is the projected peaking around 2020 and the subsequent decline of the industry revenue to approximately one-third of the historical levels by 2030,⁴ as found for example by Pike Research (2011). If this became reality, a very large percentage of jobs currently in the lighting industry would be lost, and perhaps a higher percentage in the United States.

Organic light-emitting diodes (OLEDs) are still very much in the R&D phase with little customer demand and few products in the market in the United States. (The technology is described in more detail in the section “Key Core Technology Challenges for OLEDs” in Chapter 3.) The low market share is mainly the result of high cost of manufacturing (discussed in Chapter 5) and, consequently, high product prices. OLED lighting is also not projected to be as efficacious as LED lighting in the foreseeable future (see Chapter 3) and is for these reasons not expected to contribute significantly to lighting installations or provide measurable energy savings nor jobs in the United States. The Korean manufacturer LG is the largest OLED manufacturer in the world, and most of the market activity today is in Korea, with a few demonstration projects in other countries. Based on the practical maximum surface brightness of an OLED panel (3,000 candela per square meter [cd/m^2]), current OLED technology cannot be used to make products that would replace general service incandescent lamps or general service fluorescent lamps—these products simply do not have enough surface area to allow the total light output from OLED products to be equivalent to the traditional technology products. OLED technology is therefore best suited for replacing entire luminaires, such as 2' × 2' or 2' × 4' fluorescent troffers. It is too early to regulate these products for energy efficiency, and indeed DOE has not initiated any rulemakings that would cover OLED products.

FINDING: OLED technology for lighting applications is still very much in the R&D phase with very little customer demand and very few products on the market.

FINDING: For the foreseeable future, the market penetration of OLED lighting products will be negligible because of high cost.

DEPARTMENT OF ENERGY LIGHTING PROGRAM

The congressional appropriation for fiscal year (FY) 2016 included \$24 million for DOE’s SSL programs, as well as an additional \$5 million toward the 21st century category of the L-prize.⁵ This represents a relatively steady level of funding

⁴ See, for example, Figure 2.2.

⁵ Congress provided that “If the Secretary finds solid-state lighting technology eligible for the Bright Tomorrow Lighting Prize, specified under section 655 of the Energy Independence and Security Act of 2007, \$5,000,000 is included in addition to funds for solid-state lighting research and development.” See Joint Explanatory Statement, Division D: Division

since 2007 (see Figure 2.5). The split between LED and OLED R&D spending is shown in Figure 2.6 for the past 5 years. These R&D programs have consumed approximately 40 percent of DOE’s lighting program budget over this period of time. Finally, Figure 2.7 shows the split between Core, Manufacturing, and Product R&D spending⁶ for FY 2015 for the combined LED and OLED R&D programs. The Core Technology R&D sleeve comprises the majority of R&D spending and addresses the primary emitter, the downconverters (e.g., phosphors and quantum dots) and physiological impacts of light (DOE, 2016a; p. 144). This includes R&D to reduce current droop of blue emitters and to close the “green gap.” The product development area focuses on encapsulation including tuning the refractive index to improve light extraction (DOE, 2016a; p. 148). DOE’s program is focused on improvements in energy efficiency as well as on lighting quality. DOE holds annual stakeholder meetings to determine the R&D needs that industry cannot support on its own, and the process has received little to no criticism. The rest of this section gives some detail on the various elements of the program.

DOE—through its consultants and national laboratories—publishes several reports on SSL on a regular basis. Navigant Consulting has been publishing reports characterizing the U.S. lighting market since 2002, the most recent in 2012. These reports are generally regarded as very useful by stakeholders and cited often in various contexts. DOE also publishes a multiyear energy savings forecast (DOE, 2016b), which is based on the projected average LED efficacy shipped in a given year. There are also other organizations that publish forecasts of energy savings⁷ relating to the adoption of SSL. Finally, DOE also publishes a report on LED adoption (Navigant, 2015)—this report gives estimates of the average and best efficacy for each application in that year, and energy savings estimates, based on two scenarios: one is an estimate of what energy savings have been achieved during that year, and the other is a hypothetical estimate of the potential energy savings based on a scenario where the best efficacy products available at that time were to be used instantaneously to convert all U.S. lighting installations to

D-Energy and Water Development and Related Agencies Appropriations Act, 2016, p. 28.

⁶ These are defined as follows: “Core Technology Research—Applied research encompassing scientific efforts that focus on new knowledge or understanding of the subject under study, with specific application to SSL. Core technology research aims to demonstrate scientific principles, technical application, and application benefits. Product Development—The development of commercially viable, state-of-the-art SSL materials, devices, or luminaires using concepts from basic and applied research. Manufacturing R&D—Research to develop advanced manufacturing approaches to reduce cost of SSL sources and luminaires and improve product consistency and quality, with the additional benefit of supporting the development of U.S.-based manufacturing” (DOE, 2016b; p. 1).

⁷ See, for example, York et al. (2015). In this report, Jennifer Amann projects 1.3 percent savings in U.S. electricity consumption in 2030 from advanced commercial lighting design and controls, and Dan York predicts 1.1 percent savings from residential LED lamp replacements.

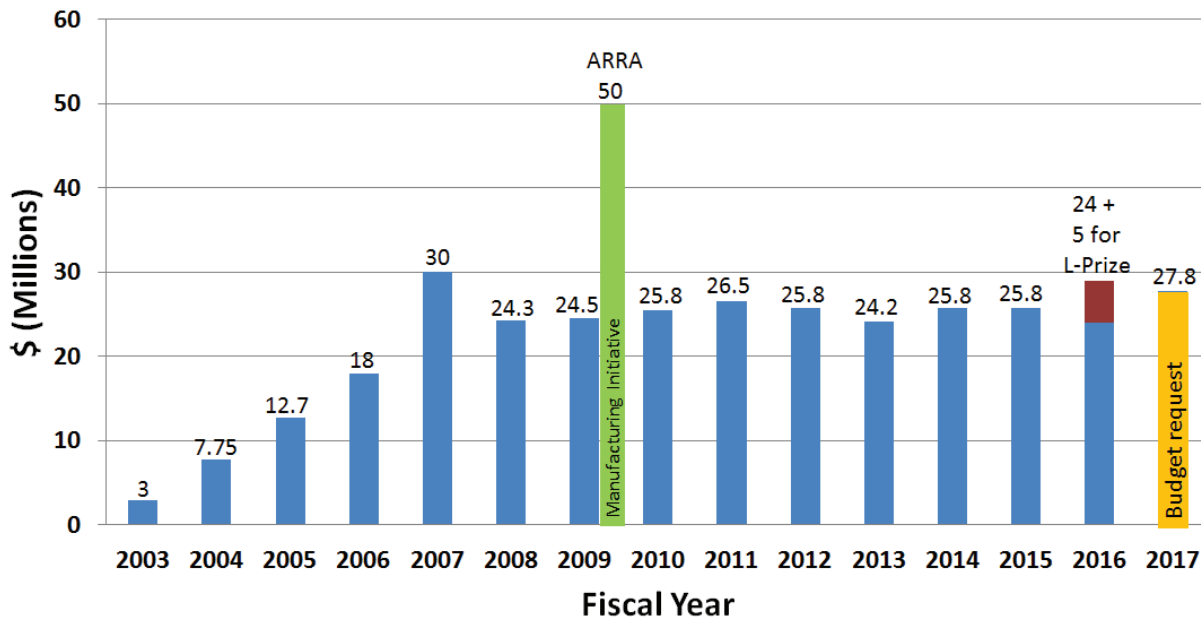

FIGURE 2.5 Budget authority for the Department of Energy’s Lighting Program by fiscal year since 2003. The 2016 figure is from the Joint Explanatory Statement of the 2016 Consolidated Appropriations Act. The figure for 2017 is the President’s Budget Request of \$27.8 million, which includes \$3.8 million for the 21st Century L-prize. The National Electrical Manufacturers Association and the Next Generation Lighting Industry Alliance have proposed that the budget be increased to \$30 million, of which \$5 million would be for the L-prize. NOTE: ARRA, American Recovery and Reinvestment Act.

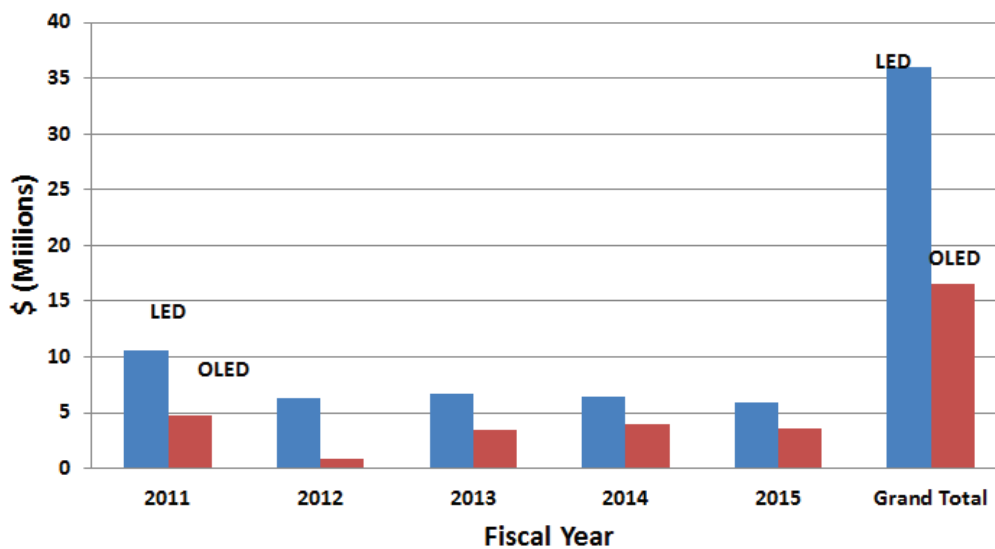

FIGURE 2.6 Comparison between light-emitting diode (LED) and organic light-emitting diode (OLED) research and development spending over the past 5 years.

SSL—called the overnight potential. Figure 2.8 is a summary of the actual and *overnight potential* energy savings from the 2016 SSL R&D Plan (DOE, 2016a). The potential source energy savings of nearly 5 quadrillion British thermal units (quads) is roughly in agreement with the 2035 projected source energy savings in the recent energy savings forecast

report, although roughly two-thirds higher than an earlier report in that series (DOE, 2014b) that had predicted nearly 3 quads in savings by 2030. The two product applications with the biggest potential energy savings are low/high bay fixtures and linear fixtures, where LED technology replaces fluorescent and HID lighting.

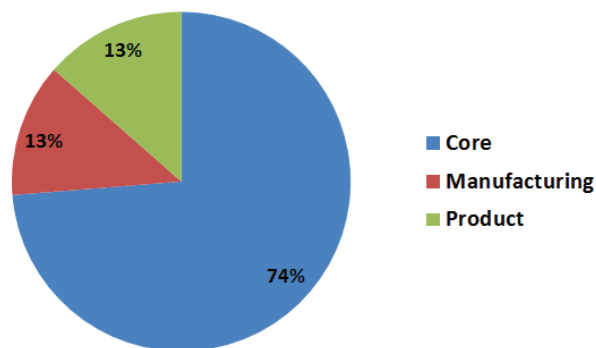

FIGURE 2.7 Split between core, manufacturing, and product research and development spending for fiscal year 2015.

In addition to the above reports, DOE funds laboratory and field evaluations, which are published as CALiPER and GATEWAY reports, respectively. These evaluations have been well received by all stakeholders.^{8,9}

Roughly 40 percent of the funding that is appropriated to DOE for SSL is spent on R&D programs. As stated at the beginning of this section, for FY 2016, Congress appropriated \$24 million and an additional \$5 million to be awarded as the 21st century prize. This funding is expected to be spent on multiyear programs that were started 2 to 3 years ago, as well as some new programs. The R&D funding is split approximately 2:1 for LEDs and OLEDs over the multiyear duration of the programs. Both LEDs and OLEDs face some fundamental challenges that are described in Chapter 3 in this report,¹⁰ but DOE's R&D funding is not limited to those challenges, supporting some programs that could be seen as short-term product development (i.e., on assembled luminaires in specific applications) that industry should fund. On the longer time scale, the market is moving toward color tunable lighting and connected lighting and is offering lighting systems as opposed to components (lamps, luminaires, drivers, controls) to provide more value added solutions to consumers and commercial end users. DOE has shown interest in these issues, but it is not a given that public money should be spent on programs where the market demand will develop naturally.

In addition to DOE funding specifically on SSL, the Secretary of Commerce has been asked by the President to administer the National Network for Manufacturing

Initiative (NNMI),¹¹ which is growing from the currently funded 9 institutions to approximately 40 over the next 2 years. Several other agencies are involved, including DOE, the Defense Advanced Research Projects Agency, and the National Institute of Standards and Technology.

DOE also funds various competitions relating to SSL. At the higher end, Congress has authorized funding for the L-prizes (Bright Tomorrow Lighting Prizes), which are intended to “spur lighting manufacturers to develop high-quality, high-efficiency SSL products to replace the common incandescent light bulb.” Three such awards were authorized, one for an LED replacement for the 60 W incandescent lamp, another for an LED replacement for the PAR 38 halogen lamp, and the third for a 21st century design, which is expected to have features not seen in traditional technology. Thus far, one such L-prize has been awarded to Philips Lighting for the development of an LED light bulb to replace the 60 W incandescent light bulb. DOE revised the L-prize for the development of an LED replacement for the PAR 38 lamp in 2013 before suspending it in 2014 when it was judged that current products fell far short of reaching the goal.¹² The final congressional appropriation for FY 2016 is for the 21st Century lighting product, for which there is funding at the \$5 million level, as mentioned previously. The L-prize is, in practice, limited to large corporations that have the resources to invest in significant development, perhaps requiring investments larger than the prize itself.

In addition to the L-prizes, DOE—in collaboration with the Illuminating Engineering Society (IES) and the International Association of Lighting Designers (IALD)—has provided funding for the Next Generation Luminaires Design Competition. This competition is open to anyone and small businesses can participate.

Finally, DOE sponsors many stakeholder meetings on SSL, such as workshops on R&D development and market development, which occur annually, and other roundtable and working group meetings relating to SSL.

In its FY 2017 budget request, DOE requested \$3.8 million for the 21st Century lighting product prize. The prize will challenge industry to create a lamp with 150 lm/W with high lighting quality. As mentioned in the caption to Figure 2.5, the National Electrical Manufacturers Association (NEMA) and the Next Generation Lighting Industry Alliance have proposed that this budget line item be increased to \$5 million.

Although the installation of medium base LED lamps increased six-fold from 13 million to 202 million between 2012 and 2015 (Figure 2.9)—there were fewer than 400,000

⁸ *LED Magazine* regularly publishes articles on these reports.

⁹ In FY 2015, more than 5,000 CALiPER reports were downloaded from the DOE SSL website, and a video highlighting the key findings of CALiPER's T8 series of reports marked almost 10,000 views. (Karen Marchese, Akoya Online, personal communication to Martin Offutt, National Academies of Sciences, Engineering, and Medicine, July 5, 2016.)

¹⁰ Specifically, green LEDs, current droop in LEDs, light extraction from OLEDs.

¹¹ AMNPO, “Manufacturing USA—The National Network for Manufacturing Innovation,” <https://www.manufacturing.gov/nnmi/>, accessed March 7, 2017.

¹² Residential Lighting, “DOE Suspends L Prize PAR38 Competition,” June 27, 2014, <http://www.residentiallighting.com/doe-suspends-l-prize-par38-competition>.

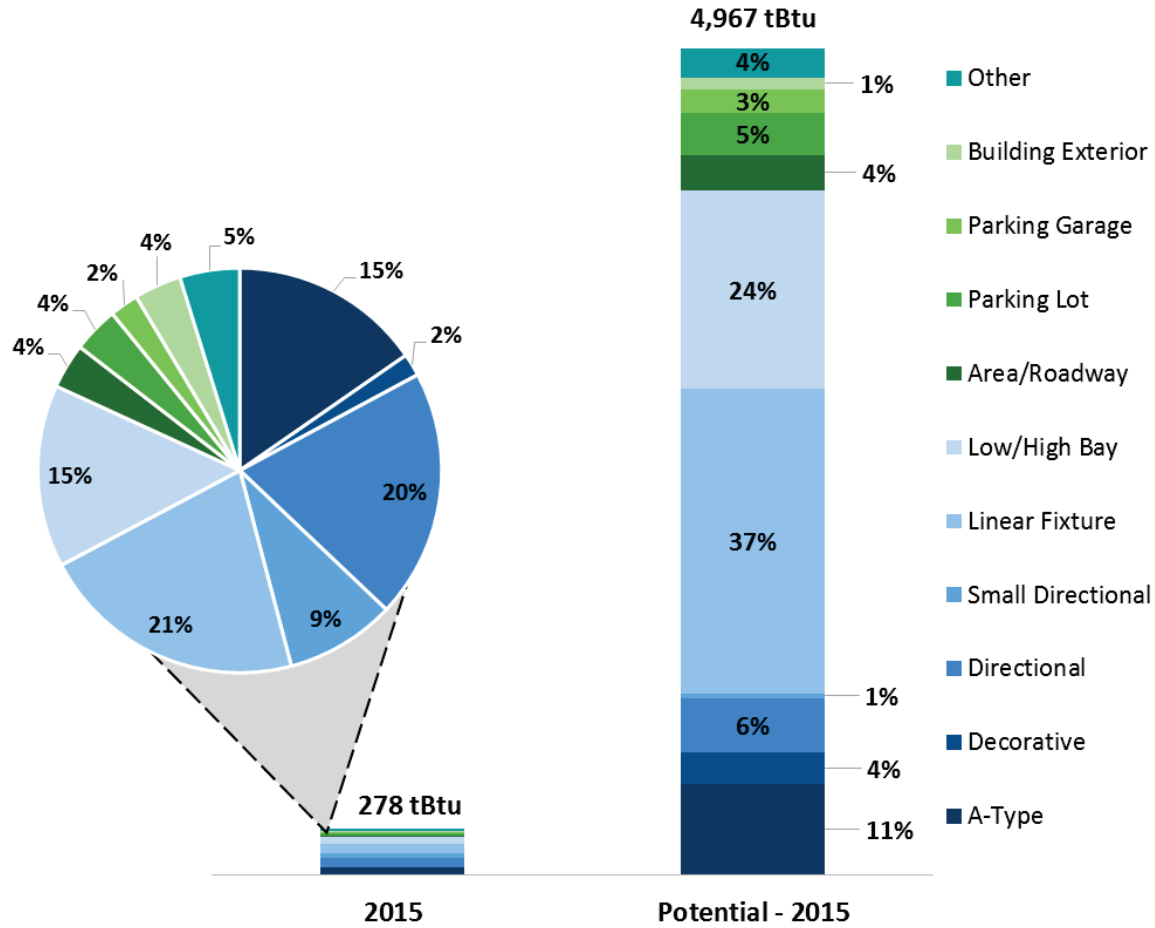

FIGURE 2.8 Comparison of 2015 adoption and potential source energy savings from light-emitting diodes (LEDs). In 2015, about 6 percent of the potential energy savings were achieved using LED technology then available, consistent with the market penetrations estimates for that year. The contributions from different technologies for 2015 are indicated in the pie chart, because the detail is not visible in the bar graph. While the potential energy savings in linear fixtures are the highest in the overnight potential scenario, in 2015 this class of products underperformed. For reference, the potential energy savings of 4,967 trillion British thermal units is equivalent to 1,456 terawatt-hours (TWh), not accounting for losses between source and site energy consumption. SOURCE: DOE (2016a, p. 28).

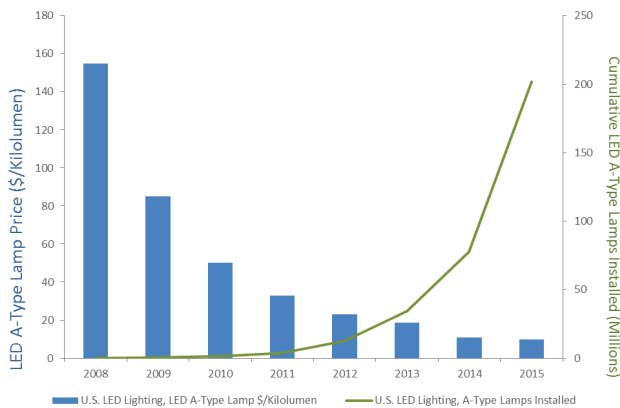

FIGURE 2.9 Deployment and price for light-emitting diode (LED) A-type lamps installed 2008 to 2015. SOURCE: DOE (2016d).

installations in 2009—these LED lamps, commonly used in residential applications, account for just 6 percent of installed lighting. This is a result of about a 90 percent cost reduction since 2008 (DOE, 2016d) (see Figure 2.9). In 2010, there were about 3.27 billion incandescent lamps in the residential sector (DOE, 2014b). In order to continue and accelerate the penetration of LED bulbs in this sector, there needs to be education of consumers so that they are aware of the advantages of these new bulbs, especially of the increased energy efficiency. In the 2013 National Research Council report, there was a finding and recommendation (6-7) about the need for DOE to partner with industry and states for a public outreach program. No such program has been initiated. Industry representatives meeting with the committee (CREE, GE, Philips) indicated that a joint government-industry consumer education program could fuel the increase of the sale of LED bulbs.

Labels¹³ help, but there is still confusion among consumers. The appropriateness of lamps for different applications may not be clear to consumers, such as lamps that are not recommended for use in enclosed luminaires. An example of this may be a surface-mounted luminaire enclosed with a lens, where the lamp may overheat and fail.¹⁴

There are potential non-R&D funds for development of such a joint program. The FY 2017 budget request for “buildings, emerging technologies”—of which lighting R&D is one component—contains a new \$6 million item called Tech-2-Market (T2M) to bridge the gap between R&D and commercialization by providing data and information and partnering with manufacturers and users, and since the lighting manufacturers are interested in working with DOE, an SSL pilot education program could be initiated. Such educational program could be directed to the lighting design professionals and take place in the form of webinars, workshops, and presentations at such conferences as Lightfair, the IES Annual Conference, and the IALD Conference.

FINDING: Industry remains interested in establishing collaborative programs for outreach and education to address issues arising from the widespread adoption of SSL products.

RECOMMENDATION 2-1: The Department of Energy, in partnership with industry, retailers, states, and utilities, should develop and implement a public outreach program in support of deployment of solid-state lighting.

The DOE program has had many accomplishments since it began funding SSL research in December 2000. There have been more than 230 cost-shared R&D-funded projects that have resulted in more than 245 patents and, as discussed in Chapter 1, many SSL products are currently on the market with efficacies around 125 to 135 lumens per watt,¹⁵ with some laboratory demonstrations reaching 200 lm/W.¹⁶ The lighting industry is very much aware of the market pressures and requirements for products with good lighting quality, in addition to high luminous efficacy. There is still significant discussion among the various stakeholders (regulators, industry, academics, and the IES) about exactly what high-quality lighting means. All agree that color rendering, good flicker performance, dimmability, and choice of color temperature are elements of good lighting quality, but the exact requirements for these performance features have not been agreed upon. Some research may be needed in order to achieve consensus in these areas.

¹³ See discussion on FTC’s Lighting Facts label at the end of this section.

¹⁴ See Salant (2014) and Energy Star, “NRDC Comments on ENERGY STAR Lamp Specification-Version 2.0 Draft 1,” March 12, 2015, <https://www.energystar.gov/sites/default/files/NRDC%20Comments.pdf>.

¹⁵ DOE, “DOE Solid-State Lighting Program: Modest Investments, Extraordinary Impacts,” September 2016, https://energy.gov/sites/prod/files/2016/09/f33/ssl_overview_sep2016.pdf.

¹⁶ See references 82, 83, and 84 in DOE (2016a).

FINDING: Laboratory demonstrations have approached the DOE’s goal to have 200 lm/W efficacy LED luminaire products available by 2025.

RECOMMENDATION 2-2: The Department of Energy should continue investments in cost-effective solutions at 200 lm/W at the luminaire level, while also considering reliability and quality of light. Quality of light needs to be defined with the help of all relevant stakeholders, including—but not necessarily limited to—regulators, manufacturers, efficiency advocates, and consumer advocates.

RECOMMENDATION 2-3: The Department of Energy should continue to allocate its limited resources to leverage those research and development programs that can have a significant impact on increased SSL deployment.

RECENT CHANGES IN FEDERAL AND STATE PROGRAMS

The last comprehensive energy bill signed into law was the Energy Independence and Security Act (EISA) of 2007. As part of that bill, there were changes made to Part B of the Energy Policy and Conservation Act (EPCA) for 13 products. Over the past year, Congress has been working on new comprehensive energy legislation that would include reforms to Part B of EPCA. The House passed its package in early December 2015, and the Senate passed a very different broader package in May 2016. At the time of this writing, the House and Senate are in the process of forming a conference committee to resolve the differences.

The recent administrations in Washington, D.C., and California have been very active in regulating lighting products for energy efficiency since the 2013 NRC report. In addition, several other state governments have shown an increased focus on recycling programs for mercury-containing products, affecting manufacturers of fluorescent and HID lamps through “extended producer responsibility.” According to this, manufacturers of products containing potentially harmful substances are responsible for conducting or at least funding proper collection and recycling programs so that these substances do not end up in landfills and ultimately pollute the ground water.

Federal Laws and Regulations

DOE has regulated traditional lighting products (incandescent reflector lamps, fluorescent and HID lamps and ballasts, as well as HID luminaires) over several rounds of rule makings.¹⁷ Given the advances in, and the focus of the industry on R&D on, SSL as opposed to traditional technologies,

¹⁷ See, for example, Energy Conservation Program, Energy Conservation Standards and Test Procedures for General Service Fluorescent Lamps and Incandescent Reflector Lamps, Final Rule, *Federal Register* 74(133):34079-34179, July 14, 2009.

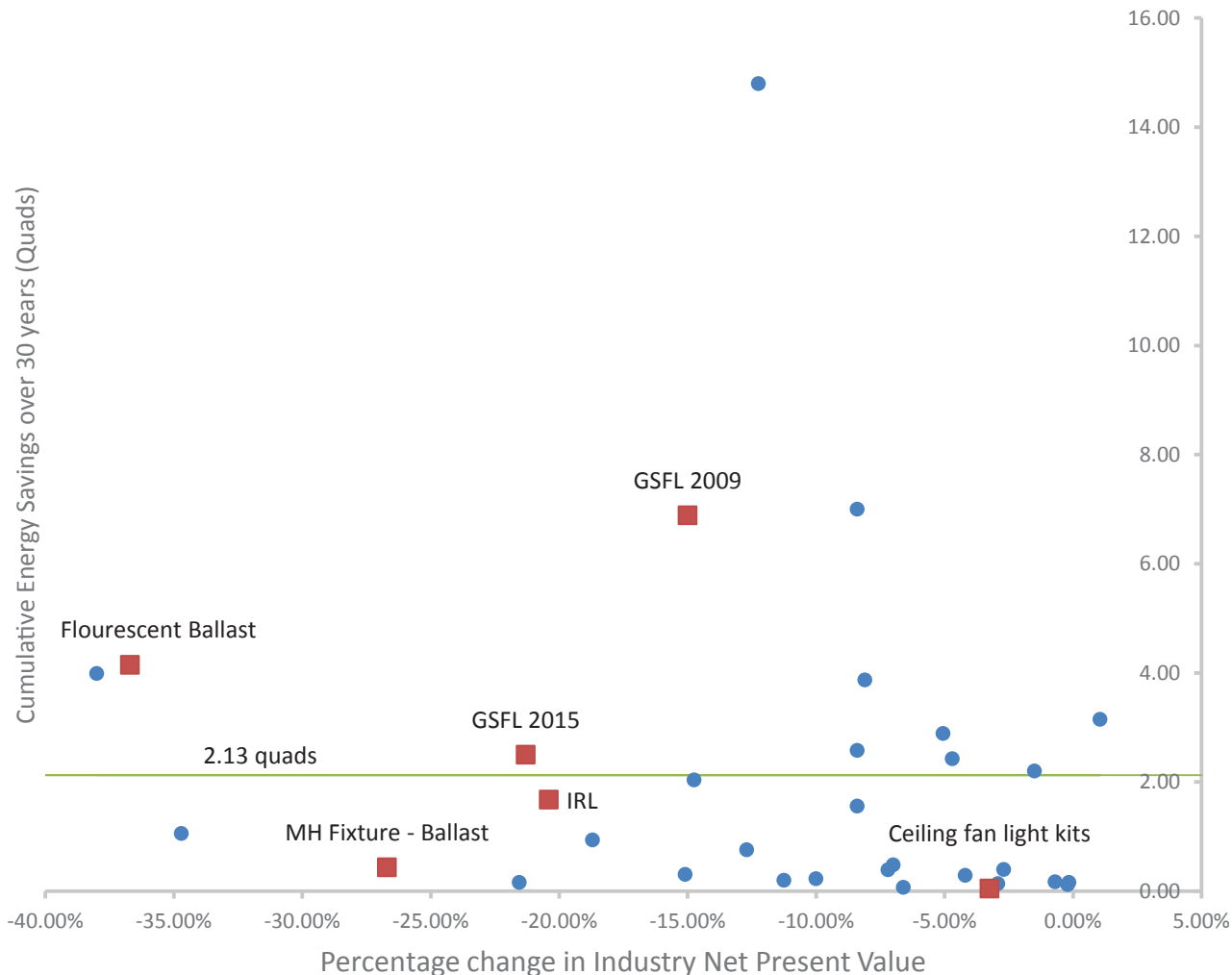

FIGURE 2.10 Effects of Department of Energy (DOE) rulemakings on energy savings and industry net present value. Data points indicate the manufacturing net present value of past rulemakings on lamps and ballasts (squares) and on other efficiency measures (circles). The horizontal line represents the average projected energy savings for DOE’s appliance efficiency rulemakings completed since 2008. The dots above the horizontal line show that some of the lighting rulemakings have contributed most significantly to the cumulative energy savings of these rulemakings, but there are some below the horizontal line that have only contributed marginally. NOTE: GSFL = general service fluorescent lamps; IRL = incandescent reflector lamps; MH = metal halide.

new rounds of rulemakings would have the effect of accelerating the transition to SSL by making lower-performing traditional lighting products obsolete through regulation. Since 2008, the lighting industry has gone through several rounds of DOE rulemakings for energy efficiency. In its public comments relating to the 2014 incandescent reflector lamp (IRL) rulemaking, NEMA commented¹⁸ that the five lighting rulemakings preceding the IRL rulemaking have resulted in a larger negative manufacturer net present value—the mea-

sure used in DOE’s manufacturer impact analysis—than the average in all rulemakings, while the national energy savings from three of those rulemakings have been lower than the average (see Figure 2.10). NEMA’s point was that final rules for lighting equipment have resulted in lower benefits and higher costs than for other typical appliances.

Since 2014, DOE has started two new lighting-related rulemakings, one for general service lamps, including regulation of standby power,¹⁹ and another for fluorescent lamp

¹⁸ See Kyle Pitsor, NEMA, letter to Brenda Edwards, U.S. Department of Energy, regarding Docket Number EERE-2011-BT-STD-0006, NEMA Comments GSFL IRL NOPR, June 30, 2014, <http://www.nema.org/Policy/Pages/Rulemaking-Comments.aspx>.

¹⁹ Energy Conservation Program, Energy Conservation Standards for General Service Lamps, Notice of Proposed Rulemaking, *Federal Register* 81(52):14528-14630, March 17, 2016.

BOX 2.1
Energy Independence and Security Act
2007 Requirements Regarding the 45
lm/W Backstop

(v) BACKSTOP REQUIREMENT.—If the Secretary fails to complete a rulemaking in accordance with clauses (i) through (iv) or if the final rule does not produce savings that are greater than or equal to the savings from a minimum efficacy standard of 45 lumens per watt, effective beginning January 1, 2020, the Secretary shall prohibit the sale of any general service lamp that does not meet a minimum efficacy standard of 45 lumens per watt.

ballasts.²⁰ DOE is required to conduct the general service lamp rulemaking in accordance with EISA 2007. An extract from the statute is given in Box 2.1.

In the current rulemaking on general service lamps, according to the publication of the Notice of Proposed Rulemaking (NPRM), DOE is proposing standards for LED and compact fluorescent lamp (CFL) general service lamps as incandescent lamp replacements. The proposed standards for integrated²¹ medium screw-base lamps and both integrated and non-integrated lamps with GU-24²² bases range from approximately 84 lm/W to just under 101 lm/W depending on the luminous flux in the range 310 lm to 2,000 lm.²³ If this standard is adopted, it will eliminate currently manufactured CFLs from the market. Lamp companies have indicated generally that they are not investing in fluorescent technology anymore, and, indeed, GE Lighting recently announced that it will discontinue CFLs before the end of 2016,²⁴ so CFLs will not be manufactured in or imported into the United States after the effective date of the Final Rule. In the 2,000 to 2,600 lm luminous flux range, the proposed rule has a reduced efficacy standard because LED's are not currently available at the higher luminous flux, and the best CFL's can meet that standard. In addition, DOE has

²⁰ Energy Conservation Program: Test Procedures for Fluorescent Lamp Ballasts, Correction, Notice of Proposed Rulemaking, *Federal Register* 79(203):2014-24985, October 21, 2014.

²¹ The term integrated lamp means a lamp that has a driver or ballast built into the enclosure with the light source (LED light engine or fluorescent tube) making it a single, non-separable product.

²² GU-24 bases were developed in response to requirements of the California residential building code in 2008 (Title 24, Part 6 of the California Code of Regulations). These bases have two pins, and they twist into the lamp holder (socket). Incandescent filament lamps including halogen lamps are not permitted to be manufactured using these bases. Adapters that would allow medium screw-base lamps to be inserted into GU24 lamp holders are likewise not permitted.

²³ The range in light output that DOE is proposing to regulate covers the equivalent of just over 25 W incandescent lamps to just under 150 W incandescent lamps.

²⁴ See, for example, Cardwell (2016).

concluded that it cannot consider new standards for halogen incandescent lamps, because of the Burgess amendment to Energy and Water appropriations bills, which prohibits DOE from spending appropriated funds on implementing new standards or enforcing the standards defined in EISA 2007 for incandescent lamps. It is unclear whether the 45 lm/W standard will apply to all general service halogen lamps in January 2020, or to the “fleet average” based on the shipments of various types (halogen and LED) of lamps. DOE has taken the position that because it is unable to conduct a rulemaking for incandescent lamps, the 45 lm/W backstop automatically applies, whereas industry is interpreting the statutory language (see Box 2.1) to allow a “fleet average” determination.²⁵ As of this writing, the situation is still evolving.

In addition, DOE has started another rulemaking on fluorescent lamp ballasts. This rulemaking, too, is awaiting the publication of an NPRM and is expected to define minimum federal standards for fluorescent dimming ballasts for the first time. Given the natural market transformation to SSL, it is questionable whether this rulemaking will result in significant energy savings. However, since the California Energy Commission (CEC) has adopted an efficiency standard for fluorescent dimming ballasts that would—according to the lighting industry—eliminate the vast majority of 4-foot T8 and T5 lamp ballasts from the California market, one advantage of a federal rule would be to set a uniform national standard.

DOE has also interpreted that “certain LED drivers” may be in the scope of the External Power Supply rule published in February 2014 with an effective date of February 10, 2016. The lighting industry has worked with DOE and the energy efficiency community, with the result that Congress is now in the process of moving forward with a bill²⁶ that would clarify that LED and OLED drivers are not external power supplies, and if they need to be regulated for energy efficiency, the Secretary of Energy is directed to do so through a separate rulemaking.

The Federal Trade Commission (FTC) has required consumer lamps (light bulbs) to be labeled using what they call the Lighting Facts label since January 2012. An example of this label is shown in Figure 2.11. In its first report, this committee recommended that FTC conduct a study 2 years after the effective date of the labeling rule “to determine the effectiveness of the labeling and whether it could be improved by additions and/or changes.” To the best knowledge of this committee,²⁷ such a study has not

²⁵ Personal communication with Clark Silcox, NEMA general counsel.

²⁶ The House passed H.R. 4444 on February 29, 2016. The same language was included in S. 2102, the Senate Energy Bill discussed in Section 2.5. The EPS Improvement Act, as it is known by, is not controversial but it is, as of this writing, being considered as part of a comprehensive energy bill.

²⁷ NEMA is also unaware of such a study by FTC. (Personal communication with Alex Boesenberg, Manager of Regulatory Affairs, NEMA, April 22, 2016).

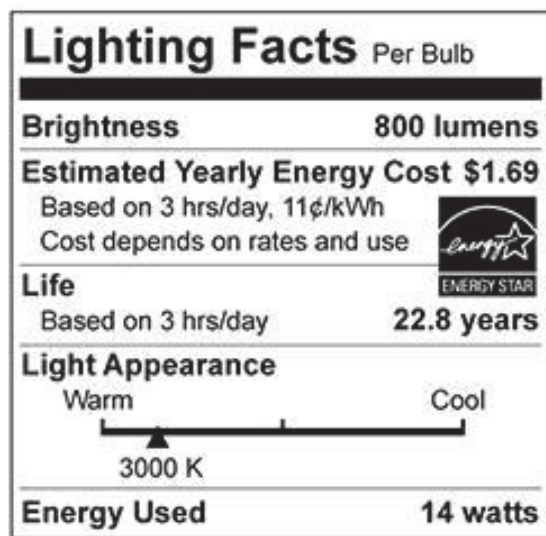
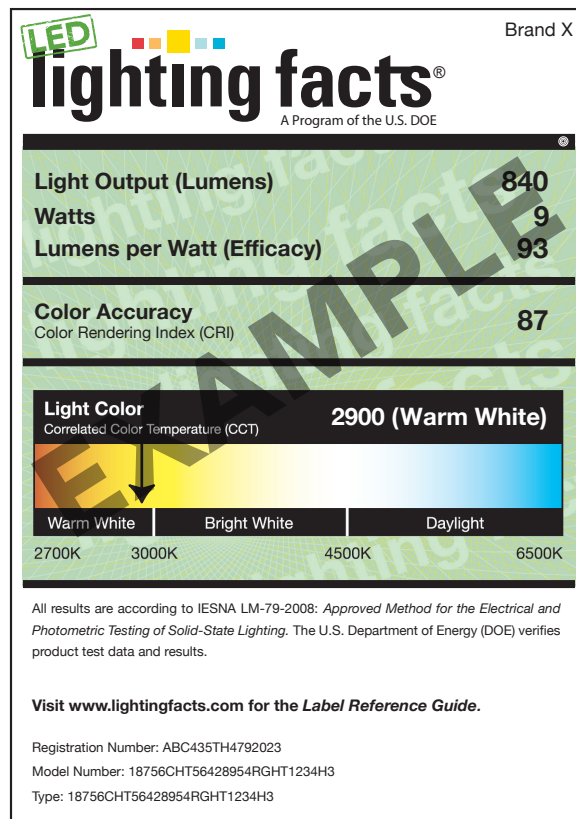

FIGURE 2.11 *Left:* The Lighting Facts label required by the Federal Trade Commission on consumer light bulb packaging since July 2011. *Right:* The Department of Energy’s voluntary Lighting Facts label.

been conducted, and there is at least anecdotal evidence that consumers do not understand the label, especially the lumen output and color designations. The lumen output of a lamp is an important concept to explain to consumers, who have been thinking about the “brightness” of a lamp using its power rating—watts. As lighting technology changes and energy efficiency improves, the equivalent lumen output to a 60 W incandescent lamp, for example, will be delivered by LED and other SSL products consuming far less power. As also discussed in the 2013 NRC report, DOE has a lighting facts label for SSL products that is often used with products that are not required to use the FTC label. Its use is voluntary, but sometimes consumers may see it on products that they purchase. It addresses similar aspects of performance as the FTC label, but in more technical terms, and is intended for the utilities and retailers as the primary audience. Since introducing it in 2014, the FTC has not conducted a study to determine the effectiveness of the labeling and whether it could be improved by additions and/or changes.

FINDING: Consumers find the FTC and DOE lighting facts labels difficult to understand. FTC still has the opportunity to study the label to determine its effectiveness.

RECOMMENDATION 2-4: The Federal Trade Commission needs to evaluate its label for effectiveness and revise it to make it more useful to consumers.



The Environmental Protection Agency (EPA) published a final rule that it calls the Clean Power Plan in 2015. The rule requires states to implement measures to curb their carbon emissions. Energy efficiency is included as a way to comply with the requirements, so efficient lighting systems, which do reduce carbon emissions, would count toward the goal. The Supreme Court of the United States issued a stay on this rule on February 9, 2016,²⁸ pending review in the U.S. Court of Appeals for the District of Columbia Circuit.

Federal Voluntary and Procurement Programs

The EPA has recently published new versions of the Energy Star Lamps and Luminaires Specifications.²⁹ The Energy Star specifications are primarily intended to cover residential grade consumer products, while the Design Lights Consortium (DLC), a project administered by the Northeast Energy Efficiency Partnership,³⁰ publishes specifications that are intended to complement the Energy Star lighting products, and focus primarily on commercial, industrial,

²⁸ See, for example, Adler (2016).

²⁹ See Energy Star lamps website at <https://www.energystar.gov/sites/default/files/Lamps%20Version%202.0%20Updated%20Spec.pdf> and Energy Star luminaires website at <https://www.energystar.gov/sites/default/files/Luminaires%20V2%200%20Final.pdf>.

³⁰ For further information see Bringing Efficiency to Light website at <https://www.designlights.org/content/about>.

and outdoor lighting products. The specifications from both programs are commonly used as the basis for rebates and other financial incentives provided by the electric utilities to consumers, commercial end users, retailers, and distributors. For more discussion about DLC and incentive programs, see section, “Recent Changes in Incentive Programs.” With regards to the latest Energy Star specifications, the lighting industry has commented publicly³¹ that the specifications for lighting products include far more performance requirements than any other appliance specifications in the Energy Star program, where most appliance specifications focus just on energy efficiency. These performance requirements relate to “quality of light” as perceived by the consumer. See also Recommendation 2.6 and the discussion preceding it in the following section, “State Laws, Regulations and Voluntary Programs.”

As discussed in the 2013 NRC report on advanced SSL, the federal government is a major consumer of products that use and supply energy. Energy use in government buildings accounts for 2.2 percent of all building energy consumption in the United States,³² and it costs the government about \$7 billion each year to heat, cool, light, and provide electricity to buildings.³³ The 2013 NRC report concluded (Recommendation 6-8) that government agencies that manage building assets can play a role in deployment of energy efficient SSL. Recommendation 6-8 recommended that the Office of Management and Budget should develop criteria for determining life-cycle costs and for including social costs in evaluating energy purchases and should incorporate this methodology into agency procurements. This has not been done. DOE has extensive expertise in applying life-cycle costing through its appliance and equipment energy efficiency standards program, and this could serve as a template for other federal efforts (DOE, 2014a). In addition, a March 2015 Executive Order directs federal agencies to reduce their greenhouse gas (GHG) emissions by a minimum of 40 percent by 2025 from 2008 levels. Purchasing of advanced SSL will assist agencies in meeting those goals.³⁴ In federal procurement programs, the government should use life-cycle cost as the financial driver in purchase decisions, not first cost of equipment, but the committee could find no evidence that it is doing so.

The Federal Energy Management (FEM) line item of the Federal Energy Management Program is developing a new voluntary leadership challenge in FY 2017 to acceler-

ate progress in reducing energy intensity in government energy-intensive facilities. According to the DOE FY 2017 budget submission, in FY 2017, the focus will be on promising building-related technology such as high-performance indoor lighting.

FINDING: Purchasing advanced SSL products and systems will assist federal agencies in meeting energy efficiency and GHG emissions goals. Such purchases could be facilitated through life-cycle cost accounting.

RECOMMENDATION 2-5: The Department of Energy should work with the Office of Management and Budget to issue guidelines for the use of life-cycle cost analysis in government procurement activities.

State Laws, Regulations, and Voluntary Programs

California is aggressive in regulating products that DOE has not regulated, using the authority granted to it by the 10th Amendment³⁵ in the U.S. Constitution. Product (Title 20) and building (Title 24 Part 6) regulations in the California Code of Regulations have been used aggressively by the CEC to meet the ambitious energy savings goals set by the California legislature in 2015 in the Clean Energy and Pollution Reduction Act.

California has for some time had a voluntary residential lighting specification for SSL products that are eligible for utility rebates (CEC, 2012), including a requirement for minimum color rendering performance, expressed in terms of the CIE General Color Rendering Index as $R_a = 90$ or higher. In 2015, this specification became the basis for a proposed minimum standard for SSL under Title 20³⁶ of the California Code of Regulations and was adopted on January 29, 2016, by the CEC with an effective date of January 1, 2018. This standard includes several other minimum performance specifications³⁷ that, according to NEMA (2015a), are likely not possible to meet simultaneously, so that only a very few currently available SSL products qualify. This raises the perennial issue of “technological feasibility.”³⁸

³⁵ The 10th Amendment says: “The powers not delegated to the United States by the Constitution, nor prohibited by it to the states, are reserved to the states respectively, or to the people.” In practice, for lighting products this means that whatever DOE does not regulate, the States (in particular California) are authorized to regulate. DOE’s constitutional authority is based on the so-called commerce clause (Article I, Section 8, Clause 3) of the U.S. Constitution, which states that the U.S. Congress shall have the power “to regulate Commerce with foreign Nations, and among the several States, and with the Indian Tribes.”

³⁶ Appliance Efficiency Regulations are found in Title 20, Sections 1601-1608 of the California Code of Regulations.

³⁷ In addition to a minimum efficacy and CRI, the regulations specify minimum performance requirements for color temperature, color consistency, power factor, lumen maintenance, standby power, rated life, survival rate (for compliance with requirements in Title 24 Joint Appendix 8) and audible noise.

³⁸ California law requires efficiency standards to demonstrate that the

³¹ See, for example, NEMA, “NEMA Comments on Draft ENERGY STAR® Program Lamp Specification v2.0 Final Draft,” December 18, 2015, https://www.energystar.gov/sites/default/files/NEMA%20Comments_4.pdf.

³² DOE, “Buildings Energy Data Book,” last update March 2012, <http://buildingsdatabook.eren.doe.gov/>.

³³ DOE, “Federal Laws & Requirements Search,” http://www4.eere.energy.gov/femp/requirements/guidelines_filtering, accessed March 7, 2017. Note: The federal government spends \$20 billion annually on energy, but a large fraction of that is on non-building energy use.

³⁴ “Planning for Federal Sustainability in the Next Decade,” Executive Order 13693 of March 19, 2015.

Also, as discussed above, DOE has begun a rulemaking on general service lamps and small-diameter directional lamps that affect these same SSL products that when effective,³⁹ will preempt this California standard. Thus, California consumers could be subject to a short-term lack of SSL product availability (approximately 2 years starting in January 2018).

Additionally, the CEC has indicated that California will adopt the 45 lm/W minimum standard on January 1, 2018—2 years earlier than the rest of the nation, as authorized by EISA 2007, eliminating halogen lamps from the California market at that time. For the calendar years 2018 and 2019, it is possible that California consumers will be able to purchase only those SSL products that meet the Title 20 standard, and any remaining CFL products. NEMA has identified an estimated six or seven SSL products available in the market today, and they are commercial-grade products and thus quite expensive. If all of this plays out as predicted here, it will be very confusing to consumers. However, in their January 2016 business meeting, commissioner Weisenmiller expressed CEC's view that efficiency standards drive product development; that California has a global role in market transformation; and that consumers select inefficient products if they are available (see CEC, 2016c; pp.122-125). Such an approach, of unilaterally defining performance requirements for many aspects of lighting products, may overlook the benefits of allowing consumer choice that could be ascertained through consulting with stakeholders.

FINDING: The CEC's minimum standards for multiple performance parameters, in addition to energy efficiency, in general service lamps has limited consumer choice and made lamps expensive.

RECOMMENDATION 2-6: The Department of Energy should convene all stakeholders, including regulators, manufacturers, and advocates, to seek agreement on which of the performance parameters that are not related to energy efficiency will need to be subject to minimum performance specifications.

requirements are technologically feasible and economically justified. However, there is no definition of "technologically feasible." The California Global Warming Solutions Act of 2006 (AB 32) makes reference to "maximum technologically feasible" in its requirements. See California Energy Resources Conservation and Development Act of 1974, also known as the Warren-Alquist Act, website at http://www.energy.ca.gov/reports/Warren-Alquist_Act/; and Assembly Bill 32 Overview website at <http://www.arb.ca.gov/cc/ab32/ab32.htm>; see, for example, Part 4 clause 38560.

³⁹ The attorney for the CA Energy Commission who spoke on April 20, 2016, at the DOE public meeting stated his belief that the preemption would be effective when the federal rule is effective. The representative from DOE's general counsel's office (Dan Cohen) asserted that California is already preempted since the federal rulemaking has started. The NEMA counsel (Clark Silcox) thinks that preemption begins when the federal rule is published. In any case, no one is questioning that the California Title 20 standard will become obsolete; it is just a matter of when.

In the same rulemaking for general service lamps, the CEC has also defined a standard for the maximum standby power consumption of connected (or "smart") lighting devices as 0.2 W. Without separating standby functionality from secondary functionality in these products, such a low level could limit innovation and thus limit additional value added features. For example, the development of connected (smart) lighting systems may provide additional functions that benefit users, such as lighting that aims to enhance the health of occupants. Some of these functions have little to do with providing illumination, but some of these operations (e.g., occupant sensing) have the potential to drastically reduce the energy consumed by lighting. These systems will consume a small amount of power, depending on the service that they provide, even when the lighting is off. At this time, regulators do not appear to understand these developments sufficiently.⁴⁰ Instead, they are focusing on the luminous efficacy of the lighting system when illumination is provided and standby power consumption when the lighting is switched off. If the function of the standby mode is only to power the lighting equipment sufficiently to get input from sensors and other devices to turn lighting on when it is needed, limiting standby power consumption to a reasonable level makes sense. This issue is further discussed in Chapter 4 in the section, "Product Design and Specification."

FINDING: Regulators, such as DOE and CEC, have started to adopt standards that limit standby power consumption in lighting products.

RECOMMENDATION 2-7: The Department of Energy, the California Energy Commission, and other regulators should consider standby power consumption separately from the power consumption of secondary functions of lighting products, so that the development of innovative lighting products is not impeded.

The CEC has concluded a rulemaking on dimming ballasts for fluorescent lamps. The commission indicated during the rulemaking process that its intent was to eliminate the least efficient products from the California market. The test procedure initially defined the total output to the lamps from the ballast as the useful power and the efficiency was defined as the total output divided by the input (= ballast losses + total output). The lighting industry agreed with this interpretation. However, in May 2016, the CEC appeared to have reversed itself and defined the useful power to be the lamp arc power (which produces light), while counting the lamp filament heating as part of the ballast loss. The minimum standards that were adopted by the CEC in 2015 are high enough that

⁴⁰ Pursuant to Title 20 of the California Code of Regulations, the rule for Small Diameter Directional Lamp, Portable Luminaires, and General Service Light-Emitting Diode Lamps requires a standby power consumption of 0.2 W or less starting January 1, 2019. See CEC (2016b, p. 14). The language was adopted on January 27, 2016.

virtually no dimming ballasts would have met them with this interpretation. After many rounds of discussions with the industry, and nearly 2 months with no dimming ballasts having been certified for sale in the CEC database, the commission informed the lighting industry in late August that it was going back to the 2015 definition of ballast output power. Fluorescent dimming ballasts are once again available for sale in California, and renovation and construction projects can continue.

In the meantime, the building regulations (Title 24 Part 6 of the California Code of Regulations) that were adopted by the CEC in June 2015 with an effective date of January 1, 2017, only allow high-efficacy products to be used in residential new construction. The building regulations for the first time since before the 2001 version allow the use of screw-base luminaires to qualify as high efficacy—except not in recessed downlights—but with the provision that screw-based lamps as well as recessed downlights must comply with the numerous performance requirements of Joint Appendix 8 to Title 24 Part 6. Halogen lamps do not comply with these requirements, so that from the effective date of the new Title 20 regulation (January 1, 2018) until the federal regulation for general service lamps becomes effective (projected to be near the beginning of the year 2020), lamp choices for residential new construction in California could be very limited.

Other states have not enacted energy efficiency regulations for SSL products to date. Instead, there are a few states (e.g., Massachusetts, Maine, Vermont, and Washington) where manufacturers have been required to either organize or financially support recycling programs for mercury-containing consumer lamps. With the apparent demise of the CFLs (see, e.g., the announcement by GE Lighting that they will discontinue to supply CFLs before the end of 2016⁴¹), these programs can be expected to see decreasing participation over time. Linear fluorescent lamps and HID lamps used in commercial and industrial facilities are already, by and large, recycled by a well-established recycling industry.

RECENT CHANGES IN INDUSTRY CODES AND STANDARDS

Building Codes

The American National Standards Institute (ANSI)/American Society of Heating, Refrigerating and Air-Conditioning Engineers (ASHRAE)/IES (2016) Standard 90.1-2013 (ANSI/ASHRAE/IES, 2016) is the latest standard covering the energy efficiency requirements for commercial and high-rise residential buildings. Currently, three States (Maryland, New Jersey, and Vermont) have adopted the equivalent of Standard 90.1-2013, as shown in Figure 2.12. The lighting power density requirements in Standard 90.1-

2013 were still based on traditional technology, so that, for example, T8 fluorescent lighting was used as a basis for lighting power density requirements for office lighting.

Standard 90.1-2016 is in development and, based on current proposals, will have many building space types with lighting power density allowances based on LED performance. The International Energy Conservation Code (IECC) cites Standard 90.1 as a compliance option for commercial buildings, along with its own prescriptive requirements that typically follow the spirit of Standard 90.1. New versions for both are published every 3 years, and the IECC version that is published 2 years after each publication of Standard 90.1 is typically considered to be equivalent to the immediately previous version of Standard 90.1. IECC 2018 is, therefore, expected to have lighting power density allowances that are based on SSL performance. Based on historical adoption rates, as illustrated in Figure 2.12, the lighting designs for new commercial buildings are expected to be based on SSL starting around 2018 to 2020, depending on the location.

In California, where the CEC publishes the state's own building energy code, known as Title 24 Part 6 of the California Code of Regulations, lighting power density allowances were in some cases based on SSL in the 2016 version and may be expected to form the basis for virtually all applications in the 2019 version.

Recently, building energy codes have started to stipulate that alterations to lighting installations comply with both the lighting power density allowance and the control requirements. In California, several small retrofitters commented⁴² to the CEC that this constituted an unreasonable burden on the end user and started to cause those retrofitters to lose business. As a response, the CEC loosened the alteration requirements in the 2016 version of Title 24 Part 6,⁴³ so that according to the new code, alterations only need to address lighting power density requirements. The balance between achieving energy efficiency and keeping retrofits practical has not been easy to achieve, and the details for retrofit requirements can be expected to evolve.

DOE's involvement in energy code development is based on a line item in its budget, which for FY 2017 requests \$6.3 million (DOE, 2016c; p. 236). As such, it appears to be adequately funded. DOE staff participate actively in ASHRAE meetings and IECC hearings, and the Pacific Northwest National Laboratory has ample support to help with code development.

Industry Standards

The lighting industry and many other stakeholders are keenly aware of the problems consumers experience with CFLs (see pages 28 to 32 of NRC [2013]) and do not want

⁴¹ Diane Cardwell, op. cit.

⁴² See, for example, the comments by Mr. Thomas in CEC (2015, p. 104).

⁴³ These requirements have not yet been published by the CEC. See Section 141.1 in CEC (2016a).

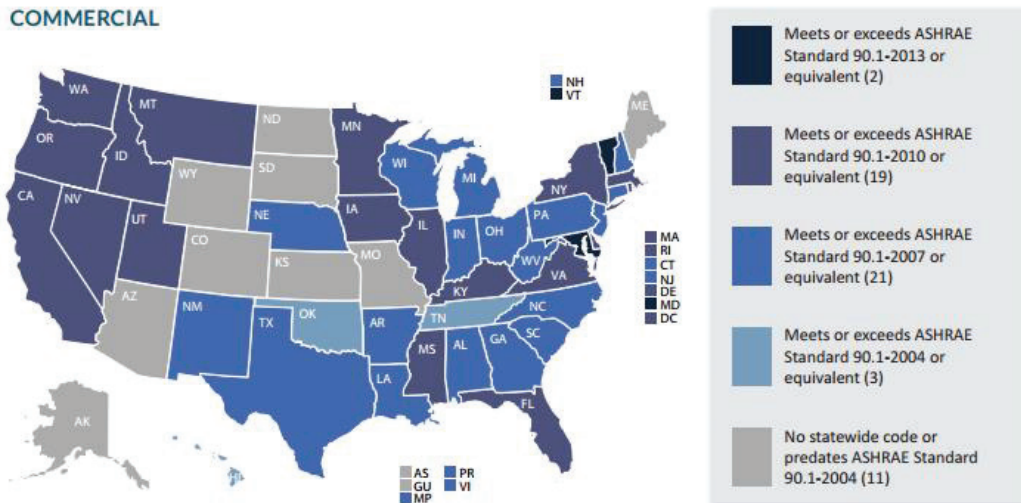

FIGURE 2.12 Adoption of building energy codes in the United States. NOTE: ASHRAE = American Society of Heating, Refrigerating, and Air-Conditioning Engineers. SOURCE: Building Codes Assistance Project, <http://bcapcodes.org/wp-content/uploads/2015/11/status-map-both-august-2016-04>, accessed August 10, 2016.

to repeat those mistakes with LEDs. Nonetheless, two characteristics of screw-based LED lamps have the potential to create dissatisfaction. The first issue is the relatively small amount of space available for the driver circuit in a screw-based LED lamp intended to serve as a replacement for the incandescent lamp (shown in Figure 2.13). Incandescent lamps have inherent thermal inertia—the light output continues even when the mains voltage reaches zero—but LEDs do not have the same characteristics. The light output of the LED will stop immediately when power ceases to be applied. Therefore, the light output is modulated according to the 60 Hz mains voltage input, especially in low-cost driver designs, to a much larger extent than it is with filament lamps, result-

ing in higher percentage flicker. The driver design has to specifically address this issue in order for the flicker effect to be mitigated—usually by adding energy storage so that voltage to the LED continues to be available through the main voltage zero crossings.

The second issue, because LEDs are energy efficient, is that they have a lower power than the incandescent lamps with an equivalent light output, which causes compatibility issues with dimmer circuits that were designed for incandescent lamps. Traditional incandescent dimmers have a minimum load requirement, ranging typically from 20 W to 40 W, which in many LED applications is higher than the total LED load. A different dimmer design is required for LED lamps to operate reliably.

The lighting industry has started to address both of these issues through the development of standards for flicker performance and lamp-dimmer compatibility. NEMA SSL 7A is a standard that describes basic compatibility between an LED lamp and a dimmer, with requirements and test procedures for both products. The first version of SSL 7A was published in 2013 (NEMA, 2013), and a revision was published in early 2016 (NEMA 2015b). NEMA SSL 7B, which is currently under development, is a performance standard for LED lamps and dimmers that is expected to address dimming performance (such as range of light output and smoothness of dimming), level of audible noise generated by the lamp and dimmer, as well as stability of light output. For the last performance characteristic, SSL 7B will cite another NEMA standard—a standard covering temporal lighting artifacts (such as flicker)—that is currently also under development.

Several ANSI standards already exist for lamp shapes and physical dimensions, and new ones will be developed



FIGURE 2.13 A comparison between a screw-in incandescent lamp (left) and light-emitting diode (LED) lamps (two on the right) designed to replace the incandescent lamp. These designs illustrate the point that space is at a premium with LED lamps and their built-in drivers. SOURCE: Courtesy Philips Lighting.

as new LED lamps are introduced to the market.⁴⁴ These standards ensure that LED replacement lamps fit into the lighting fixtures where they replace traditional technology products. The Zhaga Consortium is a global lighting industry organization established in 2010 with the purpose of standardizing LED light engines and associated components. It currently has 144 members, comprised primarily of manufacturers in the lighting industry, and has developed an extensive range of standards that address mechanical, electrical, thermal, and photometric properties of LED light engines and other components that they are connected to in a lighting installation.

Underwriters Laboratories (UL) in the United States first published UL 8750 in 2009 to address safety requirements for LED equipment. Other UL standards are in development to cover safety requirements for other SSL products. Internationally, the International Electrotechnical Commission (IEC) has published a series of standards that cover various safety and electromagnetic compatibility requirements for SSL. These UL and IEC standards are well established in the market. UL has also started a Class P LED driver program that is expected to help with the adoption of LED lighting. Until now, luminaire manufacturers have had to test each different driver using the UL testing method, and list each driver in the luminaire construction file, in order to have the luminaire listed for all desired combinations. This put LED lighting at a disadvantage because with fluorescent luminaires any UL-listed ballast can be used as long as the temperature at a designated location on the ballast does not exceed the maximum indicated by the ballast manufacturer. The luminaire manufacturer is permitted to conduct this testing in its own laboratory without incurring additional certification costs. When using LED drivers that have been certified through the Class P driver program, the luminaire manufacturer is permitted to substitute one driver for any other Class P driver by just performing the temperature test, and will retain the UL listing of the luminaire. This program is just starting, so it is too early to comment on results.

RECENT CHANGES IN INCENTIVE PROGRAMS

The public utilities commissions in many states have directed electric utility companies to spend some percentage of their revenue on programs that provide incentives to end users to improve energy efficiency in their buildings. These programs are required as a market transformation tool because new products that are more energy efficient than the ones they replace are typically also more expensive. Such has been the case with lighting products as well.

Utilities have typically relied on nonprofit organizations that were specifically set up for the purpose of developing model incentive programs, rather than developing the pro-

grams on their own. The most active of these organizations are the Consortium for Energy Efficiency, based in Boston; the Northeast Energy Efficiency Partnership, also based in Boston; and the Northwest Energy Efficiency Alliance, in Portland, Oregon. These programs have led to a certain level of consistency among participating utilities, but most of the programs are concentrated in the coastal areas with dense populations—utilities in these regions operate with less reserve capacity than in other regions, so energy efficiency programs are seen as an effective tool to ensure that there are no disruptions in service. Building additional generation is expensive and has a long lead time before it is available. In addition, the California Investor Owned Utilities have budgeted staff time to develop and administer their own programs, such as that run by the Pacific Gas & Electric Company (PG&E) (see Box 2.2). Consequently, electric utilities operating in several states have provided rebates and other such incentives to residential customers for the use of energy efficient lighting products, such as CFLs. In many of these residential programs, the EPA Energy Star program has been either directly cited as a requirement or otherwise used as guidance to qualify products. In some cases, utilities even purchased qualifying CFLs and gave them out to residential consumers free of charge. As already noted, consumer reactions to CFLs were not always positive, so the CFL programs have ended or are about to end, and some of them have been replaced by LED programs. LED market share is still quite

BOX 2.2 PG&E Rebate Programs

Pacific Gas & Electric Company (PG&E) has initiated a comprehensive rebate program for light-emitting diodes (LEDs) in the commercial sector and in 2015 issued the Lighting Rebate Catalog. As of January 1, 2015, PG&E added incentives for all linear LED solutions, including plug-n-play linear LED replacement lamps, through all Energy Watch Direct install programs. Small and medium businesses can take advantage of the program by contacting their Energy Watch program for a no-cost audit and technical assistance. There are LED troffer fixtures and integrated troffer retrofit kits. The higher the efficiency, the larger the rebate. PG&E provides a list of qualifying performance requirements and products. The rebate is offered on a per kilo lumen (1,000 lumens) basis rather than a per fixture basis. In addition, PG&E is offering rebates on a \$/fixture basis for interior LED high bay and low bay lighting and LED exterior area lighting. Rebates for compact fluorescent lights (CFLs) were no longer available after May 30, 2016. There is no LED rebate program for (residential) consumers, but PG&E provides a discount for lamps purchased at stores such as Home Depot and Costco. One needs to look for lamps with a PG&E tag.

⁴⁴ ANSI C78 committee activities are almost entirely devoted to SSL today.

small, with NEMA estimating that shipments of A-line LED lamps are about 5 percent of the total, CFLs and halogen A-lamps making up the majority. Nevertheless, Efficiency Vermont has reported⁴⁵ a 46 percent market penetration in 2014 of screw-base LED lamps, with a 2018 projection of 75 percent market penetration. It attributes this success to the utility programs in Vermont.

The Design Lights Consortium (DLC) produces a Qualified Products List for commercial lighting products, including LED products. This list is commonly used by utilities to determine product eligibility for their efficiency programs. The criteria for inclusion in the Qualified Products List includes system efficacy, power factor, harmonic distortion, correlated color temperature (CCT), color rendering index (CRI), warranty, and lumen maintenance. The DLC requires manufacturers to follow appropriate testing procedures (e.g., IES LM-79, IES LM-80, IES TM-21) and have their results independently verified, and it requires qualified SSL products to use DOE's Lighting Facts label. Installation-specific criteria, such as glare, application efficacy, and dimmability, are not considered or reported. Manufacturers must pay a fee to include their products on the Qualified Products List, whereas Energy Star and Lighting Facts are free. In addition to the Qualified Products List, the utility efficiency programs are starting to make use of lighting systems and "advanced lighting controls" (including occupancy sensors and daylight sensors) to replace the component based approach of the past. Accordingly, DLC is developing specifications for advanced lighting control systems. The annual fee for a manufacturer to register a qualifying lighting system is \$14,500. The incentive programs that are being piloted today offer the end user a rebate of 20-50 cents per square foot of renovated or newly constructed space for these types of advanced lighting control systems.

PUBLIC POLICY AND MARKET TRANSFORMATION OUTSIDE THE UNITED STATES

Solid-state lighting research is funded by governments in Europe, China, Japan, and Korea.⁴⁶ The European Commission and the German Federal Ministry of Education and Research provide a combined funding of at least \$70 million per year, almost triple that of the DOE budget. It is harder to find estimates for spending by the Asian governments, but the total government spending in China and Japan has been estimated to be more than 10 times that of DOE. Even in Korea, with a smaller economy, government spending has been almost the same as in the United States.

The remaining sections of this chapter focus on the phase out of traditional incandescent and halogen lighting and their replacement with SSL products in various parts of the world.

⁴⁵ Dan Mellinger, 2014 DOE SSL Market Development Workshop, Detroit, Mich.

⁴⁶ N. Bardsley, "Government Support for R&D in Solid State Lighting," January 15, 2016.

Europe

The European Commission regulates energy efficiency and related requirements for lighting products that are placed into market in the European Union (EU) through several directives and regulations, such as the Energy Using Products Directive (ErP Dir. 2009/125/EC) and the Energy Labelling Directive (2010/30/EU).

The phase out of nondirectional filament lamps will be in effect, subject to implementing legislation by member states, in the EU by September 2018. Directional incandescent lamps will be phased out in September 2016. The exception is low-voltage (primarily MR16) lamps, which will not be completely phased out but will have requirements for increased efficacy and increased life rating compared to the current standard.⁴⁷ The effect will be an increase in price for the remaining halogen MR16 lamps.

The market penetration of LED products in Europe has been relatively modest⁴⁸ with a market share of about 5 percent and installed base of 1.3 percent in 2013. This is comparable or even lower than the corresponding figures in the United States.

The European Commission has also implemented energy labeling regulations for all lamp products. Currently, there are several schemes on the market, with efficiency categories from A to G, A+++ to D, and others, causing some confusion with consumers. In July 2015, the commission proposed to revamp and simplify these labels back to a single category with efficiencies from A to G. An example of these labels is shown in Figure 2.14.

As a result of the self-certification of lighting products in the European Union relating to the energy efficiency label, as well as the so-called CE-mark indicating conformity with product safety regulations, there is a higher level of market surveillance in the EU regarding noncompliant products compared to the United States. Despite that, it is reported that many noncompliant products are imported into the EU—for example, incandescent lamps have been imported as heat lamps in relatively large quantities.⁴⁹ The self-certification practice in the EU for labeling products to be in compliance with regulatory requirements has led to an increased need for market surveillance and a large number of imported products that do not comply with the requirements.

⁴⁷ The efficacy standards for MR16 GU.53 lamps will be as follows: minimum 180 lumens for 20 watt; 300 lumens for 35 watt; and 540 lumens for 50 watt lamps. See *Official Journal of the European Union* L 342, December 14, 2012, p. 15.

⁴⁸ VITO, "Preparatory Study on Light Sources for Ecodesign and/or Energy Labelling Requirements: Final Report, Task 7," released October 31, 2015, <http://ecodesign-lightsources.eu/sites/ecodesign-lightsources.eu/files/attachments/LightSources%20Task7%20Final%2020151031.pdf>.

⁴⁹ See, for example, Reuters, "German 'Heatball' Wheeze Outwits EU Light Bulb Ban," Green Business News, October 15, 2010, <http://www.reuters.com/article/us-germany-heatballs-idUSTRE69E3FS20101015>.

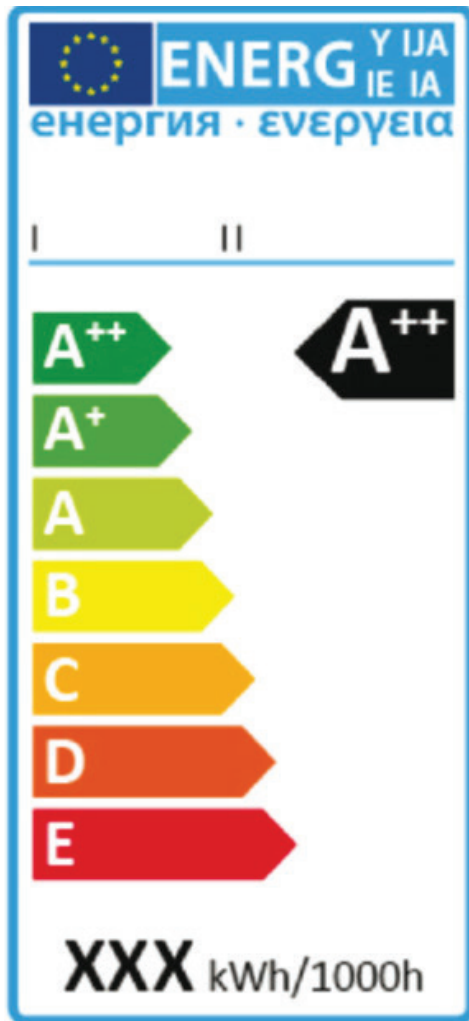

FIGURE 2.14 An example of energy efficiency labeling for lighting products in the European Union. A++ represents the most efficient, and E the least efficient products in this example. Further information is available at European Commission, “Energy Labelling Tools,” <https://ec.europa.eu/energy/en/energy-labelling-tools>, accessed August 10, 2016.

Japan

In Japan, there is no government mandated phase-out of incandescent lighting, nor any formal energy efficiency regulations for lighting products. Instead, the Japanese Parliament has passed a fairly general act on the Rational Use of Energy, which authorizes the Ministry of Economy, Trade and Industry to enforce certain energy efficiency measures in various applications, such as in buildings. Nevertheless, the Japanese market has voluntarily transitioned to energy efficient lighting products, mostly LED lighting at this point, following the March 2011 earthquake and tsunami that caused the subsequent shut down of all nuclear power plants. Although the market share of LED replacement lamps at 8

percent is quite modest, new LED luminaires already account for 70 percent of the luminaire sales.⁵⁰ Japan has the highest level of market penetration of SSL products (installed in sockets) in the world, which has happened without government regulation. The government has proposed a ban on the manufacture and importation of fluorescent lamps starting in 2020.⁵¹

The Japanese lighting industry expects all new luminaire shipments to be using SSL technology by 2020, and the Japanese government has set a goal to have the entire installed base of luminaires in buildings as well as outdoors converted to SSL by 2030.

Other Countries and Regions

Many other governments regulate lighting products for energy efficiency and are starting programs to phase out incandescent lamps. Cuba was the first country to ban all filament lamps in 2005, forcing the residential market completely to CFLs in that country, and Australia followed by phasing out traditional incandescent lamps in 2009 while keeping halogen lamps available. China has implemented the first three stages of a phase-out, and only lamps rated less than 60 W are available. The country is in an evaluation phase to determine whether further phase-outs are necessary. The market penetration of LED lighting products in China is quite high, ranging between 20 and 40 percent depending on application.⁵² Other European countries as well as Russia and Israel follow programs similar to those in the EU, and Canada’s program is very similar to that in the United States. The 2013 NRC report includes a table (NRC, 2013, p. 29) that contains information about incandescent lamp phase-out in 23 countries and regions. In addition, the United National Environment Programme runs its en.lighten Initiative and has a well-designed website that gives the current status of filament lamp phase-out in most of the countries in the world.⁵³

REFERENCES

- Adler, J.H. 2016. Supreme Court puts the brakes on EPA’s clean power plan. *Washington Post*. February 9.
- ANSI/ASHRAE/IES (American National Standards Institute, American Society of Heating, Refrigeration, and Air Conditioning Engineers and Illuminating Engineering Society). 2016. “Standard 90.1- Energy Standard for Buildings Except Low-Rise Residential Buildings.” New York and Atlanta, Ga.

⁵⁰ Japanese Lighting Manufacturers Association, “2016 Production and Sales Statistics Graphs: Lamps,” 2016, http://www.jlma.or.jp/tokei/pdf/lamp_graph01.pdf.

⁵¹ LEDinside, “Japan to Phase-out Incandescent and Fluorescent Lights by 2020,” November 27, 2015, http://www.ledinside.com/news/2015/11/japan_to_phase_out_incandescent_and_fluorescent_lights_by_2020.

⁵² China-LED, “2014 China LED General Lighting Industry Market Research Report Released,” February 12, 2015, <http://www.china-led.net/news/201502/12/18491.html>.

⁵³ UNEP, “en.Lighten Efficient Lighting for Developing and Emerging Countries,” <http://www.enlighten-initiative.org/>, accessed March 7, 2017.

- Cardwell, D. 2016. G.E. to phase-out CFL bulbs. *New York Times*. February 2.
- CEC (California Energy Commission). 2012. *Voluntary California Quality Light-Emitting Diode (LED) Lamp Specification: Final Staff Report*. CEC-400-2012-016-SF. Sacramento, Calif.
- CEC. 2015. Lead Commissioner Hearing on Proposed Revisions to Title 24 Parts 1, 6, and 11: March 3, 2015 Transcript. Docket 15-BSTD-01. Sacramento, Calif.
- CEC. 2016a. *Building Energy Efficiency Standards for Residential and Nonresidential Buildings*. CEC-400-2015-037-CMF. Sacramento, Calif.
- CEC. 2016b. "Proposed Revised Express Terms, 15-Day Language for Small Diameter Directional Lamp, Portable Luminaires, and General Service Light-Emitting Diode Lamps." Docket Number 15-AAER-6. Document Number CEC-400-2015-044-15DAY-REV. Sacramento, Calif.
- CEC. 2016c. "Transcript of the 01/27/2016 Business Meeting." Docket Number 16-BUSMTG-01. Sacramento, Calif.
- DOE (U.S. Department of Energy). 2014a. *Energy Savings Forecast of Solid-State Lighting in General Illumination Applications*. Prepared by Navigant Consulting, Inc. for the U.S. Department of Energy, Office of Energy Efficiency and Renewable Energy, Building Technologies Program. Washington, D.C.: Navigant Consulting, Inc. August.
- DOE. 2014b. *Energy Conservation Standards Activities: Report to Congress*. Washington, D.C. https://energy.gov/sites/prod/files/2014/02/f7/2014_feb_report_to_congress.pdf.
- DOE. 2015. *Solid-State Lighting R&D Plan*. Washington, D.C. May.
- DOE. 2016a. *Solid-State Lighting R&D Plan*. Washington, D.C. June.
- DOE. 2016b. *Energy Savings Forecast of Solid-State Lighting in General Illumination Applications*. Washington, D.C. September.
- DOE. 2016c. *FY 2017 Congressional Budget Request: Volume 3*. DOE/CF-0121. Washington, D.C. February.
- DOE. 2016d. *Revolution . . . Now: The Future Arrives for Five Clean Energy Technologies—2016 Update*. Washington, D.C.
- Navigant Consulting, Inc. 2015. *Adoption of Light-Emitting Diodes in Common Lighting Applications*. Prepared by Navigant Consulting, Inc. for the U.S. Department of Energy, Office of Energy Efficiency and Renewable Energy, Building Technologies Program. Washington, D.C. July.
- NEMA (National Electrical Manufacturers Association). 2013. "Phase Cut Dimming for Solid State Lighting: Basic Compatibility." SSL 7A-2013. Arlington, Va.
- NEMA. 2015a. "California Energy Commission Pursuing Regulatory Requirements to Mandate LED Bulbs That Are Less Efficient, More Expensive." December 18. <http://www.nema.org/news/Pages/California-Energy-Commission-Pursuing-Regulatory-Requirements-to-Mandate-LED-Bulbs-That-Are-Less-Efficient-More-Expensive.aspx>.
- NEMA. 2015b. "Phase Cut Dimming for Solid State Lighting: Basic Compatibility." SSL 7A-2015. Arlington, Va.
- NRC (National Research Council). 2013. *Assessment of Advanced Solid-State Lighting*. Washington, D.C.: The National Academies Press.
- Pike Research. 2011. *Energy Efficient Lighting for Commercial Markets*. Boulder, Colo.
- Salant, K. 2014. Clearing up some of the confusion on LED lights. *Washington Post*, February 3.
- York, D., S. Nadel, E. Rogers, R. Cluett, S. Kwatra, H. Sachs, J. Amann, and M. Kelly. 2015. *New Horizons for Energy Efficiency: Major Opportunities to Reach Higher Electricity Savings by 2030*. Report Number U1507. Washington, D.C.: American Council for an Energy Efficient Economy.

3

Assessment of LED and OLED Technologies

INTRODUCTION

The insertion of new solid-state lighting (SSL) technologies has caused a revolution in lighting over the past decade. During the 3 years following the first study, the lighting industry has undergone a fundamental restructuring, as detailed in other chapters of this report. It is possible to view this rapid change as proceeding in phases. According to this view, the first wave (dumb and “rudimentarily smart lighting” [Tsao et al., 2014]) has just been completed. This wave was dominated by retrofit into existing sockets and characterized by rapid increases in luminous efficacy. If there is to be a second wave (smart and feature-rich lighting), SSL technology will need new advances that encompass, beyond efficacy alone, the quality and form factors of lighting, their connectedness and controllability, and their cost-effective insertion into new applications.

This chapter discusses the key technological issues that still challenge light-emitting diode (LED) and organic light-emitting diode (OLED) technologies and that limit their high-efficiency performance. A basic understanding of the structure and, hence, operational principles of LEDs and OLEDs is important in setting the context of the technological challenges to be addressed and the possible new directions the lighting industry will take. Accordingly, the LED and OLED “primers” from the 2013 NRC report are also reprinted in the Chapter 3 Annexes 3.A and 3.B, “An LED Primer” and “An OLED Primer,” respectively. The primers treat the basic device structure and metrics of device performance.

Figure 3.1 illustrates the recent progress made in lighting efficacy for both LEDs and OLEDs by examining the performance of different types of products on a yearly basis. Figure 3.1(a) distinguishes commercial LED packages with different LED architectures, showing current values of efficacy of 140 lumens per Watt (lm/W) for “warm white” lighting and 160 lm/W for “cool white” packages. Figure 3.1(b) displays

the analogous projection in efficacies for OLED panels, based on data for both laboratory panels and commercial products.

There are a few clear observations we can make based on the data from Figure 3.1:

- There has been steady progress in increased efficacy of both LED packages and OLED panels. Yet for both LEDs and OLEDs, the projections suggest that still-higher efficacies are possible.
- While higher efficacies are possible for LEDs, the ultimate (saturation) values of efficacy differ and depend on the device physics of the package technology. These options include the following: (1) the current predominant architecture using phosphor-coated LEDs (pc-LEDs), with predicted saturation efficacy of 255 lm/W; (2) a “hybrid” technology LEDs (hy-LEDs) utilizing light emitted directly from LEDs together with light from pc-LEDs, for which the saturation efficacy is predicted to be 280 lm/W; and (3) the use of four separate LEDs (red, blue, green, and amber), where the saturation efficacy is predicted to be 330 lm/W. The predictions of different saturation efficacies for the different architectures indicate both the dominant mechanisms of efficiency loss today and the potential for improvements in the future.
- Data on commercial, qualified OLED panels remains sparse, and product performance in a given year is non-uniform, making future projections of progress all the more difficult. However, Figure 3.1(b) suggests that OLED panel efficacies of 190 lm/W are possible.
- LEDs and OLEDs for SSL remain at very different stages of development, and the critical challenges, and hence critical investments, for these technologies are expected to be different.

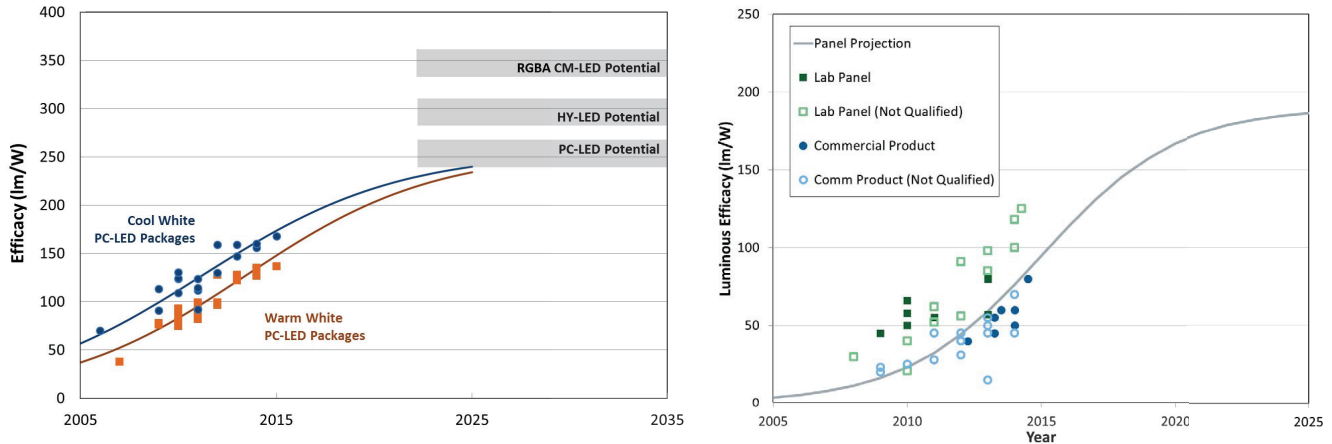

FIGURE 3.1 (a) Efficacies of commercial light-emitting diode (LED) packages measured at 25°C and 35 amperes per square meter (A/cm^2) input current. Blue data points and fit for “cool white” lighting (5,700 K); orange data points and fit for “warm white” lighting (3,000 K). Gray bars indicate approximate long-term, future potential efficacies for three white-light architectures: phosphor-coated LEDs (pc-LEDs), “hybrid” technology LEDs (hy-LEDs), red, blue, green, and amber (RGBA) color-mixed LEDs (cm-LEDs). (b) White-light organic light-emitting diode panel efficacy projections. SOURCE: DOE (2016).

- As described in Chapter 2, DOE has provided research and development (R&D) support for SSL over a number of years and has published periodic roadmaps and R&D plans for the augmented capabilities of SSL. Current investments by DOE and the lighting industry in the core LED and OLED technologies have resulted in remarkable success; further investments are needed to consolidate the gains achieved in the first wave and pave the way for new, exciting, and perhaps unpredictable possibilities in the second wave. Yet for LEDs, the return on investment in developing energy savings alone appears to be getting much less attractive for industry. However, reduction in energy consumption is a key element of DOE’s mission. A greater understanding of the technological possibilities is needed to resolve these seemingly disparate objectives: on the one hand, the objective of (1) a continued singular focus on lumens per watt, which has been a focus of DOE, balanced against the objective of (2) development of new applications, capitalizing on increased light quality and integrated systems, for which the metric of lumens per watt is a secondary goal. This latter objective reflects the evolving industrial and market point of view. As industry is mindful of the cost of producing lighting systems, as well as lighting quality (based on customer demand), given the very competitive environment, industry is unlikely to on its own, fund higher-risk research aimed at improvements of lighting efficacy (lm/W).

Nonetheless, further technological solutions are necessary to deliver the maximum savings in energy for SSL. In addition, advances in core technology are necessary to imple-

ment the new generation of “smart,” feature-rich lighting applications, which require multicolor emission, narrowband emission spectra, and high modulation speeds.

KEY CORE TECHNOLOGY CHALLENGES FOR LEDS

There are four key performance factors to be considered in the evaluation of an LED package, and there are consequent trade-offs in the separate optimization of each of those performance factors. The trade-offs and ultimate efficiencies obtainable define the continuing challenges in improvements of the core technologies for LEDs.

- Drive current density* determines the amount of luminous flux (light output) delivered to the LED package.
- Junction temperature* refers to the local heating of the p-n junction, at the core of the LED operation (see Annex 3.A). As shown in Figure 3.2, both increased drive current density and increased junction temperature degrade the efficiency of LED output, by reducing the “power conversion efficiency” (Figure 3.2(a)), or the resulting light output (Figure 3.2 (b)).¹

¹ The concepts of *internal quantum efficiency* (IQE) and *external quantum efficiency* (EQE) are introduced in Annex 3.A, “An LED Primer,” and Figure 3.4 demonstrates the *droop* or reduction in EQE as a function of current density in the LED. There are various ways of describing the efficient performance of an LED: Figure 3.7 uses *power conversion efficiency*, that is, the efficiency of conversion of electrical to optical power. Figure 3.8 uses the term *wall-plug efficiency*—another term that relates the applied electrical input power to the resulting optical output power. Although the exact numbers may differ, all of these terms are a metric of the efficiency of the power input to the LED (or laser) device or system, compared to the radiant power out.

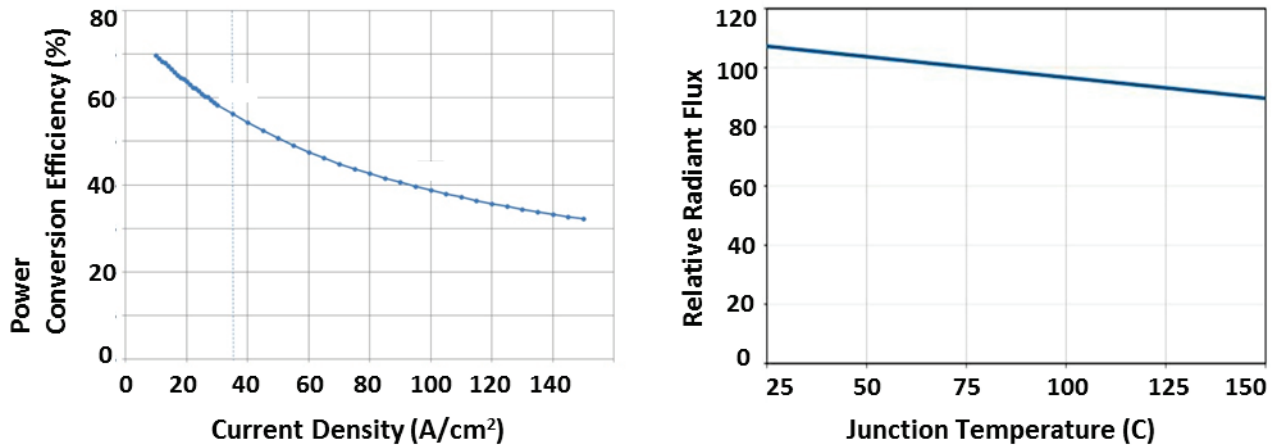

FIGURE 3.2 Two types of efficiency droop: (a) current efficiency droop and (b) thermal efficiency droop. SOURCE: Cree XLamp XT-E Datasheet.

Higher junction temperatures can lead to reduction of internal quantum efficiency (IQE) (see also Annex 3.A), increased device resistance, and other mechanisms that contribute to lowered efficiency. The data of Figure 3.2 illustrates a phenomenon commonly referred to as “droop” (reduction of light intensity). “Current droop” refers to decreased LED efficiency with increased applied current density, while “thermal droop” refers to the decreased efficiency with increased operational temperature of the device. Although high current densities can lead to higher junction temperatures, depending on the effectiveness of the LED packaging, the detailed physical mechanisms of current droop are distinctive from simple junction heating. These details are described in the section “Eliminating or Mitigating ‘Current Droop.’” Current droop has a particularly strong effect for LEDs emitting in the green and accentuates the low efficiency of LEDs at high current densities in this spectral region, giving rise to the phenomenon known as the “green gap.” This is discussed further in the section “Overcoming the ‘Green Gap.’” Thermal droop, in turn, has a particularly strong effect for red LEDs.

- *Correlated color temperature* (CCT) has been more fully discussed in the section “Introduction to Lighting” in Chapter 1.
- *Color rendering index* (CRI) has also been more fully discussed, also in the section “Introduction to Lighting” in Chapter 1. The design of an LED package represents an engineering compromise between efficacy and light quality. There is an inverse relationship between the CRI and the efficacy, as shown in Figure 3.3.

The core challenges for LED technology—droop, the green gap problem, and control over light quality—are all intimately related. Not surprisingly, droop is also an issue for OLEDs (although the physical basis for droop is different in these materials). While progress has been made in understanding and mitigating these issues, they still remain as fundamental challenges for the second wave of development.

Eliminating or Mitigating “Current Droop”

A continuing problem for the conventional III-nitride LEDs, which include, for example, gallium nitride (GaN), is the loss of efficiency under operation at high current densities (typically greater than 10 A/cm²). The phenomenon of “efficiency droop,” occurring at increased current densities, is illustrated in Figure 3.4. As the current density of the LED is increased, the external quantum efficiency (EQE, see Annex 3.A) is reduced. All commercial devices operate in some region of the droop curve, implying fundamentally reduced efficiency. The reduction of EQE at higher current densities has a profound effect on the economics of these LEDs. In the presence of droop, targeting a higher total light output in lumens now requires using multiple LED dies in a given area, each operating at lower current densities, rather than using a single LED in the same area that can be operated at a higher current density. Alternatively, lighting manufacturers might choose to use fewer LEDs, operating them at higher current densities but incurring the penalty of reduced efficiency. The impact on manufacturing costs is clear: there have been projections that a 6 percent improvement in droop could result in two or three times improvement in light output per dollar, for the same LED wall plug efficiency.² The mechanisms associated with droop have also been linked to

² E. Nelson, I. Wildeson, and P. Deb, Lumileds, presentation at the DOE Solid-State Lighting R&D Workshop in Raleigh, N.C., February 2-4, 2016.

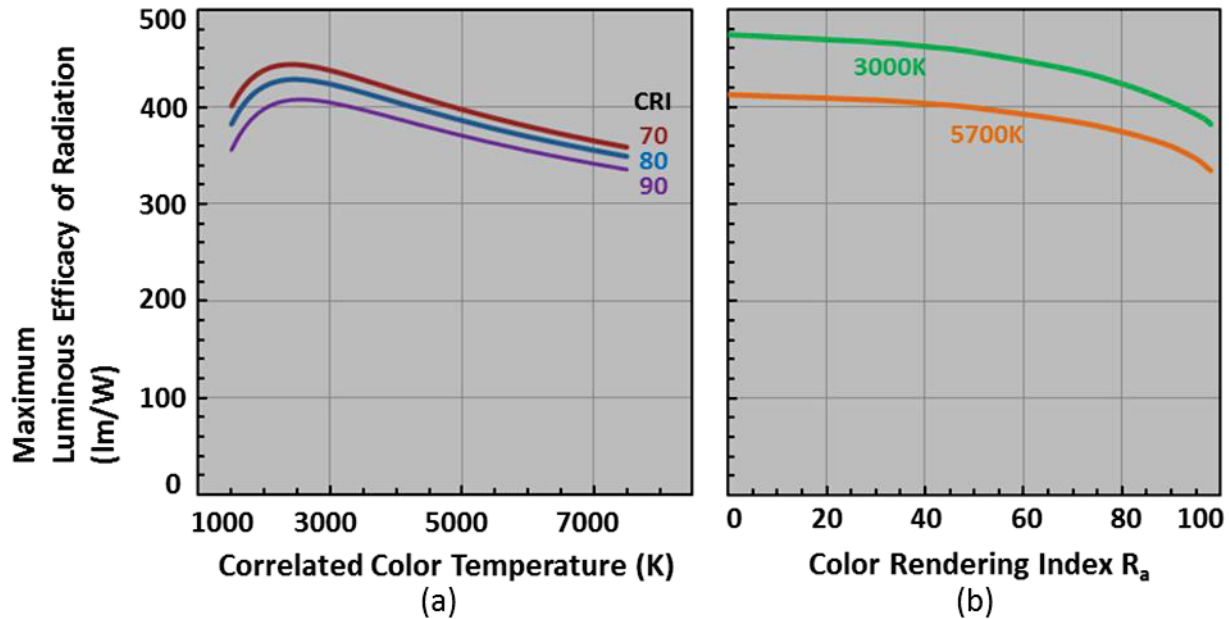

FIGURE 3.3 Theoretical limits to white light luminous efficacies versus (a) correlated color temperature (CCT) for a given color rendering index (CRI) and (b) CRI for a given CCT. SOURCE: DOE (2016). Courtesy Jeffrey Tsao, Sandia National Laboratories.

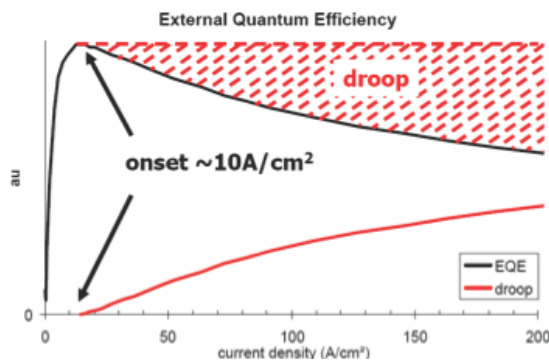

FIGURE 3.4 Schematic of light-emitting diode efficiency droop with increasing current density. The y-axis is a measure of external quantum efficiency (EQE), in arbitrary units (au). SOURCE: Denbaars, Speck, Nakamura, “Future Directions in SSL,” presentation to the committee, January 6, 2016. Courtesy University of California, Santa Barbara.

the “green gap” problem (see the section “Overcoming the ‘Green Gap’”).

The root cause of droop is still subject to controversy, despite some recent very carefully executed and analyzed experiments.³ The key factors relate to the reduced internal quantum efficiency (IQE) (which is efficiency of the

electron-hole conversion to photons) at high electron and hole concentrations (see Box 3.B.1 in Annex 3.B), and thus the mechanisms may relate to electron and hole “leakage,” the presence of a built-in electric field that reduces IQE, or mechanisms such as “Auger recombination.” This latter mechanism is particularly active under high current density: energetic electrons and holes in the LED recombine, but without the emission of light. Instead, the recombination energy is transferred to neighboring charge carriers and generates heat. It appears that there is a variety of interacting physical processes that take place in the active region of the LED: both *electronic transport* (the ease which electrons move through the device) and photon production efficiency need to be optimized, but often the improvement of one factor can only be done at the expense of the other. The situation is illustrated in Figure 3.5, which gives a schematic view of the multiple quantum well (MQW) regions in the LED, designed to facilitate radiative recombination of electrons and holes. MQWs are also discussed in Annex 3.A. The figure may allow easier visualization of the situation at high current densities, where the quantum well regions are “over-filled” with electrons or holes, the structure therefore becomes less effective in “holding” or localizing the electrons and holes, and the efficiency of light output is reduced.

A number of technical approaches hold promise for mitigating the effects of droop.

³ See, for example, Weisbuch et al. (2015).

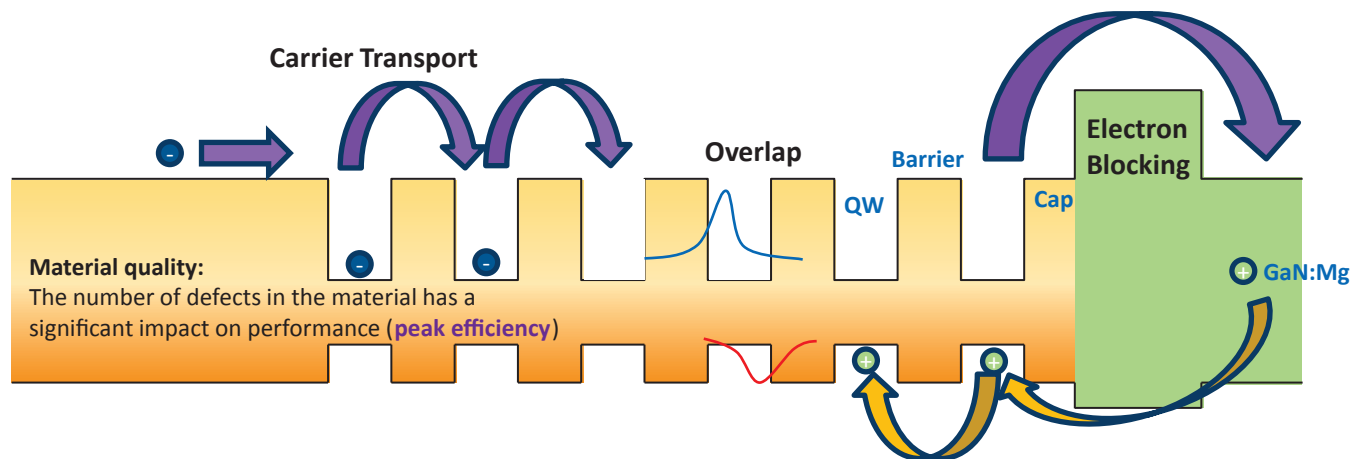

FIGURE 3.5 Schematic of a multiple quantum well (QW) region, showing injection of electrons (in purple, from left) and holes (in yellow, from right). The desired goal is recombination of electrons and holes to form photons. The schematic suggests the ways in which electrons and holes may be lost from the structure or otherwise not be able to recombine. SOURCE: Image courtesy Lumileds, Epitaxy Technology Group.

- Creating “wider active areas” (quantum wells) and minimizing high carrier densities represents one approach. Growth on substrate materials other than sapphire might facilitate the wider active areas. For example, researchers and companies have explored the use of silicon carbide (SiC) as a substrate. This approach represents a compromise between reducing droop and increasing device resistance. Most recently, there has been some success with growth on GaN substrates (David, 2015). Further discussion on alternative substrate materials is given in the sections “Improved Epitaxial Growth and Substrates” and “The Manufacturing Supply Chain and Economic Drivers” in Chapter 5.
- Stacking LEDs (or their essential elements, the p-n junction) on top of each other allows increased voltage, but with low current density. The lower current density allows the device to operate at the high efficiency part of the droop curve (Figure 3.4). The end result is to produce higher light output per unit area of LED, while avoiding droop. The multiple “LEDs” or p-n junctions, as well as their connectors would be formed through epitaxial growth. A schematic of the stacked p-n junctions, and their simulated high power performance, compared with the performance of a single junction, is shown in Figure 3.6. Notice the projected increase in wall plug efficiency with an increased number of junctions. The challenge in this approach is the development of low resistance connections (tunnel junctions allowing quantum mechanical transport) between the various LEDs.
- Another solution that might side-step the limitations of efficiency droop is to employ a laser rather than an LED to pump a phosphor to create white light (Box 3.1). There are many similarities between a

laser and an LED structure; however, the incorporation of a laser cavity to produce a nonlinear amplification of the light overcomes many of the limitations set by droop, and allows higher-efficiency operation at higher current densities. This is illustrated in Figure 3.7, which depicts the power conversion efficiency as a function of current density, for LEDs (both state-of-the-art and future devices), as well as laser diodes (LDs, also state-of-the-art and future devices). Both LEDs and LDs give off blue light (450 nm wavelength). While the power conversion efficiency of LEDs falls off, or droops, at current densities greater than $\sim 10 \text{ A/cm}^2$, current lasers reach their maximum values of power conversion efficiency at current densities as high as 1 kA/cm^2 . In fact, lasers have already been employed as white headlights in automobiles,⁴ and thus this technology is currently being implemented for commercial applications. However, Figure 3.7 also reveals some of the current limitations of using laser diodes for lighting applications:

- The peak power conversion efficiency of blue lasers (about 30-40 percent) is lower than that of blue LEDs (about 80 percent).
- Laser power conversion efficiency only applies after the laser threshold is exceeded (current thresholds are about 1 kA/cm^2).
- There is a reduction in power conversion efficiency for lasers operating at higher current densities, associated with electrical resistances in the device.

⁴ EVO, “BMW M4 shows off laser headlights with CES concept,” released January 8, 2015, <http://www.evo.co.uk/bmw/m4/14912/bmw-m4-shows-off-laser-headlights-with-ces-concept>.

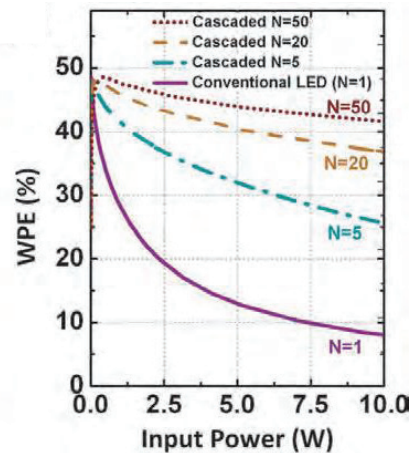
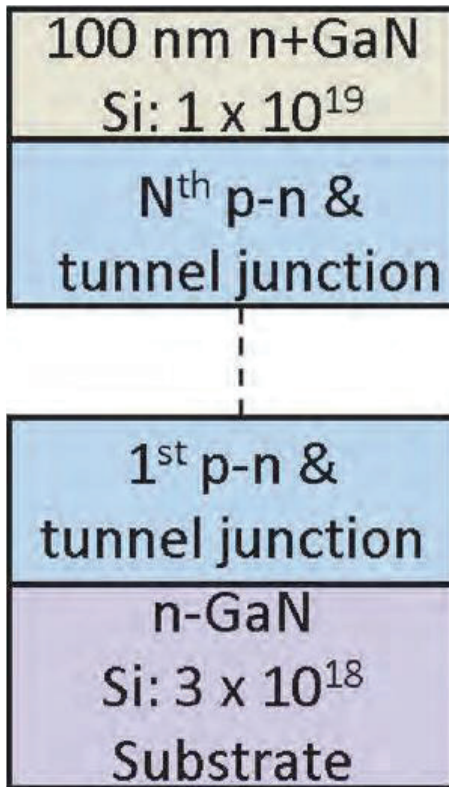

FIGURE 3.6 (a) Schematic of multiple p-n junctions, connected by tunnel junctions, (b) simulations showing the wall plug efficiency (WPE) of the light-emitting diode (LED), as a function of input power. SOURCE: Reprinted from F. Akyol, S. Krishnamoorthy, and S. Rajan, Tunneling-based carrier regeneration in cascaded GaN light emitting diodes to overcome efficiency droop, *Applied Physics Letters* 103(8):1107, with the permission of AIP Publishing.

Lasers provide additional benefits as SSL sources: they possess narrow spectral linewidths (i.e., very precisely defined wavelengths) and high modulations speeds, enabling next-wave applications. However, the technological challenges are formidable in improving state-of-the-art blue lasers to achieve the power conversion efficiencies of future lasers, as indicated in Figure 3.7.

DOE has understandably made the reduction of droop an R&D priority⁵; the truly workable solution, however, is one that will be sufficiently cost-effective to induce adoption by lighting manufacturers.

Overcoming the “Green Gap”

The loss of LED efficiency at higher current densities affects LEDs across the spectral range. The green gap is a manifestation of the efficiency droop discussed above, but affecting wavelengths in the green spectral region, and occurring at lower values of current density. The absence of high-efficiency LEDs in the green spectral range is particularly critical because the highest sensitivity of the human eye falls between 540 and 580 nanometers (nm) wavelength. Figure 3.8 illustrates the highest efficiencies achieved in LEDs as a function of wavelength: note that the green line

refers to LEDs made from InGaN, while the red line refers to LEDs made from InGaAlP. (The InGaAlP is currently used to form red LEDs, and the reduced efficiency of LEDs at the “ideal” red wavelength of 614 nm (DOE, 2016) also has a limiting effect on the efficacy of white-light LED SSL; see the section “Control Over Color-Quality”). Differing approaches to mitigating the green gap include the following:

- A focus on altering the semiconductor structure itself may enhance the emission of light at a given current value. Researchers at Rensselaer Polytechnic Institute are attempting growth of the LED structure on alternative substrates,⁶ while researchers at OSRAM have shown the feasibility of an integrated green LED structure epitaxially grown atop of a blue LED structure: the blue LED “pumps” the green LED, leading to the output of green light.⁷
- Most commercial SSL products today employ phosphors pumped by LEDs to achieve desired colors (see the section “Control Over Color Quality”). Thus, one may use high-efficiency “green” phosphors pumped by blue LEDs.

⁵ “The Droop Phenomenon,” SSL Postings (postings@akoyanonline.com), March 30, 2016.

⁶ U.S. Department of Energy (DOE), “Solving the ‘Green Gap’ in LED Technology,” <https://energy.gov/eere/ssl/solving-green-gap-led-technology>, accessed March 7, 2017.

⁷ B. Hahn, op. cit.

- Still in the experimental, evaluation stage, solutions pursued by OSRAM have resulted in improvements in the wall plug efficiency in the green portion of the spectrum; these are shown as the blue triangles denoted as “recent progress” in Figure 3.8.

Control Over Color Quality

Metrics of color quality have been discussed in Chapter 1, and the next generation of “smart” lighting applications, employing multicolor emission with narrowband emission spectra, will likely require increased control of color quality. Color quality requirements may vary as a function of applications, as discussed in Chapter 4. From a device perspective, the color of the LED is determined by the composition and

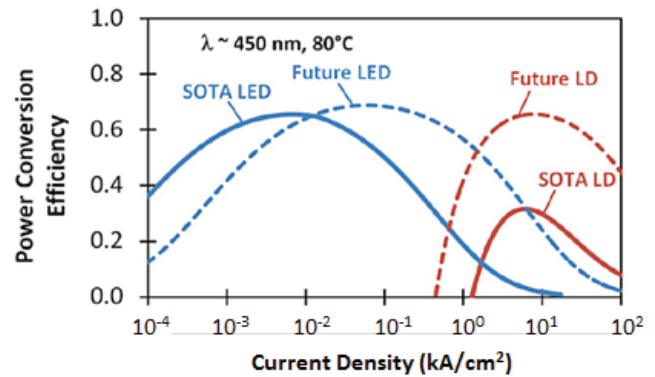

FIGURE 3.7 Power-conversion efficiencies versus input power density of a state-of-the-art, high-efficiency blue light-emitting diode (LED), compared to a state-of-the-art blue laser diode. NOTE: LD = laser diode, SOTA = state of the art, λ = wavelength. SOURCE: J. Wierer and J. Tsao, 2015, Advantages of III-nitride laser diodes in solid-state lighting, *Physica Status Solidi A* 212(5):980-985. Copyright Wiley-VCH Verlag GmbH & Co. KGaA. Reproduced with permission.

BOX 3.1 Laser Diode–based Lighting: A Possible Solution to Current Droop?

A novel and promising approach to high-power solid-state lighting (SSL) is the use of laser diodes for lighting. In particular, lasers are the most efficient converters of electrical to optical energy at high current densities, and thus may be a way to circumvent issues of current droop in light-emitting diodes (LEDs). Highly efficient lasers (~70 percent) could be used to pump phosphor white lighting sources to achieve luminous efficacies greater than 250 lm/W. Laser diodes have structure that are similar to LEDs, but also incorporate mirror structures to achieve a natural amplification of the light output, and high efficiencies at high input powers. Blue lasers with 30 percent power efficiency have been demonstrated, with the potential of achieving yet higher efficiencies.¹ For directed light applications such as headlights or projection, lasers have an advantage due to smaller spot size and ability to direct light. BMW and Audi have already introduced laser diodes for use in its headlights. Furthermore, a laser diode is one-tenth the size of an LED, which allows designers to reduce the size of the headlight. Laser-based light sources in which the blue lasers pumps a phosphor coating are beginning to displace metal halide bulbs in desktop projector markets. Casio has recently come out with a hybrid Laser/LED light source for 3000 lumen office projection.² Despite the promise and current utilization of blue lasers for SSL, as shown in Figure 3.7, there may be considerable effort needed to bring current lasers to the high-power conversion efficiencies and lower current density operation that would be most useful for SSL.

¹ C. Vierheilg, C. Eichler, S. Tautz, A. Lell, J. Muller, F. Kopp, et al., 2012, Beyond blue pico laser: Development of high power blue and low power direct green, *Proceedings of SPIE* 8277.

² T. Hoffman, 2012, “Casio Announces New Hybrid LED-Laser Projector Models,” *PCMag*, January 10, <http://www.pcmag.com/article2/0,2817,2398505,00.asp>.

thicknesses of the quantum wells that make up the active layer. The manufacturing challenges lie in controlling composition and thickness of the quantum wells that produce the different LED wavelengths. There are different limitations to the IQE (see Annex 3.A) of the quantum wells associated with different wavelengths, resulting in the different wall plug efficiencies observed for red, green, and blue (RGB) LEDs, as has been discussed in the section “Overcoming the ‘Green Gap.’”

As described in the Introduction, there are different approaches or architectures used to produce packaged LED white lights.

1. *Phosphor-converted LEDs* (pc-LEDs) are currently the dominant means of realizing LED-based white lighting. Pc-LEDs utilize a blue LED to pump phosphors that will emit at green and red wavelengths, thus producing white light. Pumping at blue wavelengths to produce light at longer wavelengths is a process known as “down-conversion.” The efficiency of the LED itself is folded in with the color-conversion efficiency of the phosphor to determine the total efficiency of the LED. A narrow band red phosphor can be added to improve the warmth of the resulting white light.
2. *Hybrid LEDs* (hy-LEDs) use a blue LED to pump a green wavelength down-converter (phosphor); the blue and green light is subsequently mixed with light from a red LED to produce white light. Currently this approach is being pursued using red LEDs based on InAlGaP, and the limitations for the hybrid approach primarily relate to the efficiencies of the red LEDs,

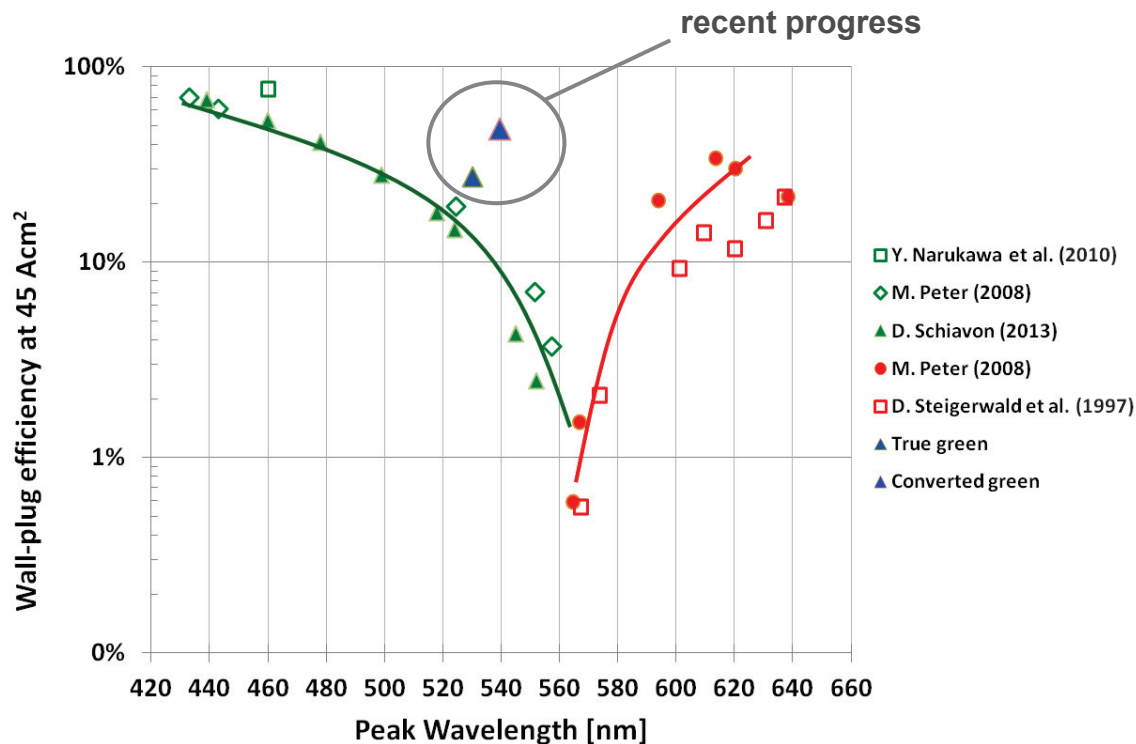

FIGURE 3.8 Light-emitting diode wall plug efficiency as a function of wavelength. Note that the axis of wall plug efficiency is given on a logarithmic scale. SOURCE: B. Hahn, OSRAM, “Closing the Green Efficiency Gap,” presentation at DOE Solid-State Lighting R&D Workshop, Raleigh, N.C., February 3, 2016. Courtesy OSRAM GmbH.

as shown in Figure 3.8. EQE of these LEDs are currently about 25 percent, and these LEDs are more greatly affected by thermal droop than InGaN-based blue LEDs.

3. *Red, green, blue, and amber (RGBA) color-mixed LEDs (cm-LEDs)* are based on directly integrating four primary LEDs—blue, green, amber, and red—to produce white light. This approach has a number of advantages in achieving subtle tunings of chromaticity and luminaire efficacy of radiation (LER). However, the different efficiencies of LEDs at the various colors, together with differences in aging or response to high power or heat, compromise the color of the light source.

Phosphors are available in a wide range of chromaticities for sensitive tuning of light quality; however, there continue to be challenges in the efficiency, thermal stability, and in the *spectral* width of these phosphors. Although the quantum yields for phosphors are currently quite high (98 percent for green, 90 percent for red), still further improvements are required, with DOE goals of 99 percent quantum yield for green and 95 percent for red, by 2020 (DOE, 2016). The thermal stability of the phosphors also are to be improved from the current value of 90 percent relative quantum yield

at 125°C, compared to 25°C, to a target value of 95 percent by 2020 (DOE, 2016). In addition, a narrow spectral width of the phosphor is desirable, since a broad width near the red portion of the spectrum, as shown in the blue curve of Figure 3.9, can introduce an orange tinge to the color. Recent progress in narrow-spectral-width phosphors holds great

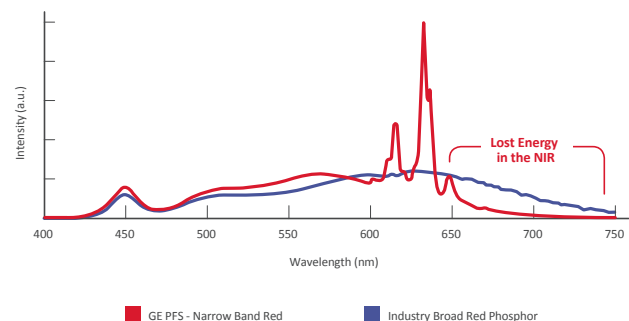

FIGURE 3.9 Spectral comparison of potassium fluorosilicate (PFS) blend light-emitting diodes (LEDs) versus industry-standard white LEDs (red curve) with broad band phosphors (blue curve). NOTE: NIR = near infrared. SOURCE: GE, “Tri-Gain™ Phosphor: Simple, High-Performance Red for LED Backlighting.” Image Courtesy of General Electric Company.

promise for future improvements in fine-tuning the color quality of LEDs.

It should be recognized that the phosphor-based approaches to achieving color quality may not adapt well to the demands of future *smart* solid-state LED lighting, which will require real-time tuning of light output to tailor white and non-white lighting chromaticity (Tsao et al., 2014).

Improved Epitaxial Growth and Substrates

The discussions above on efficiency droop and the green gap suggest that an important route for mitigation of these problems may require modified materials structures. These new structures will certainly require improvements in epitaxial growth and may use different substrates for that epitaxial growth.

Epitaxial growth is carried out through metal-organic chemical vapor deposition (MOCVD). The MOCVD deposition machines used in the manufacture of the LEDs have a huge influence on the uniformity of the wavelength and yield of white LED in a complicated process that requires control of temperature, material strength, and growth rates. There continue to be innovations and augmentations in the monitoring of the growth process: for example, DOE-funded research has helped to implement a Veeco MOCVD reactor with advanced wafer carrier design, near-ultraviolet pyrometry to monitor the temperature of the material during the growth, and utilizing a model-based means of temperature control.⁸ The resulting MaxBright™ reactor claims improved wafer yields and wavelength uniformity.⁹

Epitaxial growth processes work best when the substrate (e.g., sapphire) that serves as the template for the material growth has a structure (lattice constant) that matches that of the finally formed material. Without the one-to-one registry of the overgrown material to the template, there will be a strain in the overlayer that may eventually give rise to dislocations and defects in the material (10^7 - 10^8 cm⁻² dislocations in the best case for GaN on sapphire). Such defects will compromise the performance and reliability of the devices formed from the material. The proposed changes in device structure to reduce droop will place even more stringent requirements on MOCVD growth. Other challenges for epitaxial growth include developing new materials for green and red LEDs. These materials have large lattice mismatches to all commonly used substrates.

There have been some small advances in substrate availability since the 2013 NRC report. Sapphire (with an approximate 14 percent lattice mismatch) still has the largest share (95 percent of the market) as substrate material for

LED growth.¹⁰ Although SiC provides a closer lattice match to GaN than does sapphire and appears to have some advantages over sapphire in GaN epitaxial growth, significant numbers of dislocations are still generated during the GaN epitaxy. As “a rule of thumb” large numbers of dislocations are generated when the substrate-to-epi lattice mismatch exceeds 1 percent (in the case of GaN/SiC the mismatch is ~3 percent). The semiconductor power electronics device market has provided an impetus for the development of SiC substrates, and SiC substrates have come down significantly in cost since the last report. Although SiC substrates are still much more expensive than sapphire, SiC substrates are now available as 6” wafers with 8” in development. Cree continues to provide GaN-on-SiC LEDs. GaN substrates would provide the closest lattice match to the LED structures, alleviating issues of materials of strain and compositional control during the growth. Laboratory results have already demonstrated superior efficiency at high current densities for LEDs grown on bulk GaN substrates (Hurni et al., 2015). However, this is still a relatively young technology and is challenged by issues of cost and substrate size. The production of GaN-on-GaN devices is being undertaken by SORAA and through funded research by DOE’s Advanced Research Projects Agency-Energy.¹¹ Further discussion is given in the section “The Manufacturing Supply Chain and Economic Drivers.”

Challenges and Promises for LEDs

In recent years, there has continued to be substantial progress in achieving increased efficiency of LED-based lighting. Nevertheless, the fundamental challenges remain, relating to efficiency droop, green gap, and fine tuning of the color quality. There has been progress in the understanding of droop and the green gap, and some promising and innovative approaches have been demonstrated to mitigate these problems. Nevertheless, the adoption of these approaches and the consequent impact on SSL will inevitably be balanced against nearer-term costs as well as longer-term benefits.

FINDING: Major technological issues remain in improving the efficiency and performance of LEDs, including efficiency droop and the green gap in efficiency. Although there is a better understanding of the underlying mechanisms and possible solutions, including new approaches to lattice-mismatched epitaxy and the growth of LEDs on GaN substrates, the costs of implementing those solutions may be too expensive for industry to consider action. Laser sources, rather than LEDs for SSL, may mitigate some of the major challenges in droop and green gap, but these sources will

⁸ M. Pattison, “Led and OLED SSL Manufacturing Value Chain,” briefing January 5, 2016.

⁹ J. Jenson, Veeco, quoted in Jim Brodrick, DOE, “Briefing on DOE Solid-State Lighting Program,” presentation to the committee, November 11, 2015.

¹⁰ S. Pruitt, Strategies Unlimited, “Lighting and LEDs Market Overview and Forecast,” briefing January 5, 2016.

¹¹ J. Brodrick, DOE, briefing to the committee on January 5, 2016.

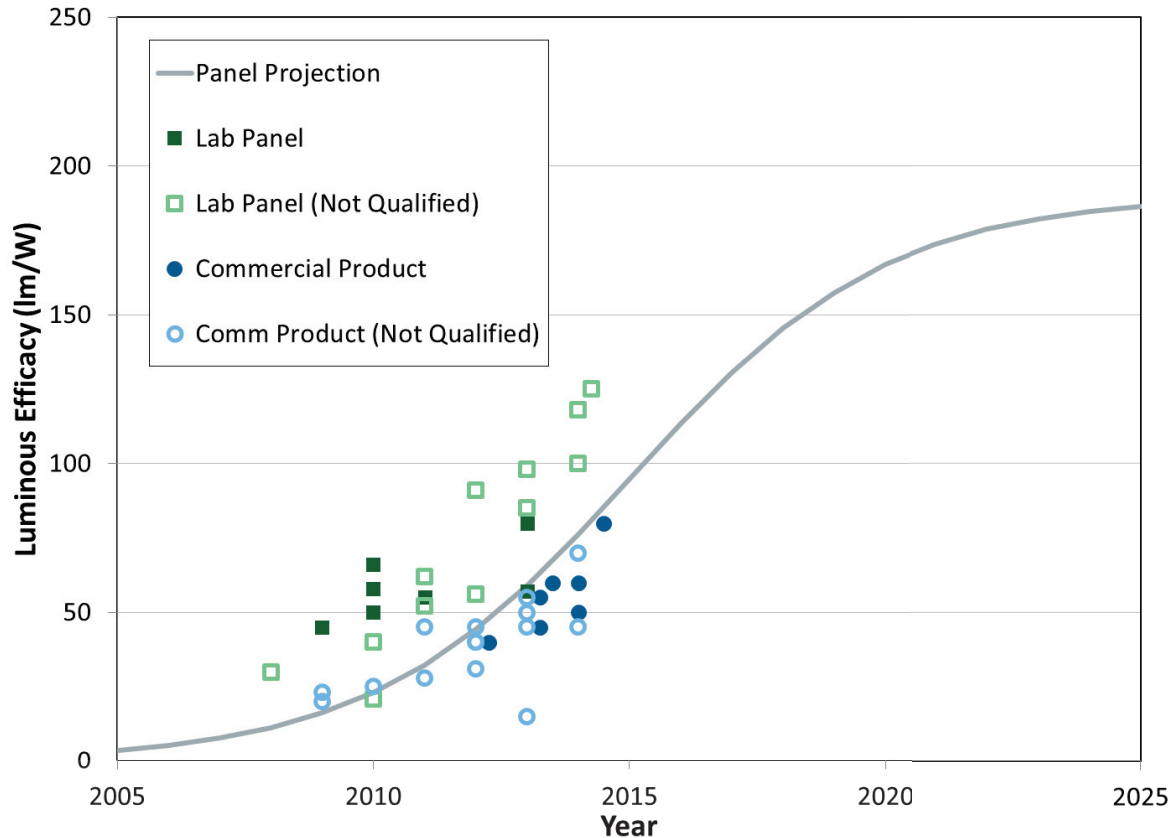

FIGURE 3.10 Projection of organic light-emitting diode efficacy. SOURCE: DOE (2016, p. 139).

require their own technological developments to realize low thresholds at low cost.

KEY CORE TECHNOLOGY CHALLENGES FOR OLEDs

There remains a great deal of interest in OLED-based lighting because of the diffuse quality of light (compared to LEDs as directional, “point-sources”) and the possibility of integration with flexible substrates, allowing a variety of form factors for OLED lighting.

As seen in Figure 3.10, progress has been made in the efficiency of OLED panels, with high potential anticipated for future improvements.¹² The 2013 NRC report identified several key technology issues to be addressed for improved OLED performance. These issues included efficient light out-coupling, or extraction, as well as the relatively short lifetime of blue emitters compared to green and red emitters. These issues remain important limitations to OLED lighting efficacy. Nevertheless, in the intervening time, at the R&D level, the luminous efficacy has reached 135 lm/W, largely due to improvements in materials and the adoption of highly

efficient light extraction schemes. On the production scale, today’s OLED panel efficacy is rated at 60 lm/W and manufacturers are promising 80 lm/W in next-generation products. Beyond the improvements in OLED efficacy, a conclusion of the 2013 NRC report was that there was as-yet not large-scale manufacture of OLEDs specifically installed for lighting, which is the root cause for the high price of OLED panels. This situation remains true today. Major growth in OLED display technologies could provide both incentive and leverage to the development of OLED lighting. Indeed, Active-Matrix Organic Light-Emitting Diode (AMOLED) displays for both mobile and TV applications form a rapidly growing business today, with estimated 2016 revenue of \$15 billion.¹³ Planned installations of new G5 (Generation 5) to G8 (Generation 8) AMOLED manufacturing lines in Korea and China are expected to fuel further growth of OLED display business and accelerate price drops. The lowered cost of AMOLED displays, OLED-TV in particular, will directly benefit the OLED lighting business, since OLED

¹² T. Komoda, China International OLED Summit, Shanghai, China, on January 21, 2015.

¹³ IDTechEx, “OLED Display Forecasts 2016-2026: The Rise of Plastic and Flexible Displays,” <http://www.idtechex.com/research/reports/oled-display-forecasts-2016-2026-the-rise-of-plastic-and-flexible-displays-000477.asp>, accessed August 23, 2016.



FIGURE 3.11 Organic light-emitting diode downlight CHALINA. SOURCE: Image Courtesy of Acuity Brands.

lighting shares a technology platform similar to OLED-TV: both are based on white OLEDs with a tandem (stacked) device architecture (described in Annex 3.B) and use mask-less vapor deposition for panel manufacturing.

FINDING: Because OLEDs for illumination and OLEDs for displays build on a common baseline of materials and devices, there is huge potential for improvements in the development of OLEDs for lighting by leveraging the infrastructure of OLEDs for displays.

Incipient Commercialization of OLED Lighting

OLED lighting panels, both rigid and flexible and in various shapes and forms, are commercially available from a few manufacturers. The lead manufacturer is LG Display from Korea. The sole U.S. manufacturer is OLEDworks in Rochester, New York. The first generally available OLED lighting product in the United States is produced by Acuity Brands (the CHALINA™ OLED pendant, Figure 3.11) and is currently sold in Home Depot as a specialty downlight.¹⁴ At a selling price of \$299 per unit, the cost amounts to \$3.75 per square inch of OLED panels. At 345 lumen total output the cost is \$1,150 per kilo-lumen, which is at least two orders of magnitude higher than the cost of LEDs. However, in terms of luminaire pricing, the CHALINA OLED luminaire can be fairly competitive to similar specialty lighting products listed at Home Depot. OLED panels are also available from OLEDworks. According to its website, the average price

¹⁴ Home Depot, “Acuity Brands Chalina 5-Panel Brushed Nickel OLED Pendant,” <http://www.homedepot.com/p/Acuity-Brands-Chalina-5-Panel-Brushed-Nickel-OLED-Pendant-CHALINA-PM-OLEDA1-5P-345LM-30K-120-DIM-B/205662976>, accessed April 2016.

(calculated for its model FL300) is approximately \$3.15 per square inch, or \$373 per kilo-lumen, not including the cost of the driver.

Increasingly, OLED panel manufacturers are offering flexible OLED lighting panels as unique and differentiating products. Figure 3.12 shows an example of such distinctive OLED lighting. Flexible products can be based on plastic (such as PET, polyethylene terephthalate) or ultra-thin glass (such as Corning’s Willow glass) substrates. Product specifications from LG indicate efficacy of 60 lm/W, similar to glass products, and L70 of 20,000 hours, about half of the glass products. The shorter L70 is likely due to encapsulation issues, which are generally more difficult to manage for flexible OLEDs. Higher moisture permeability in plastic materials and the lack of robust and cost-effective thin-film encapsulation methods are major issues in this case.

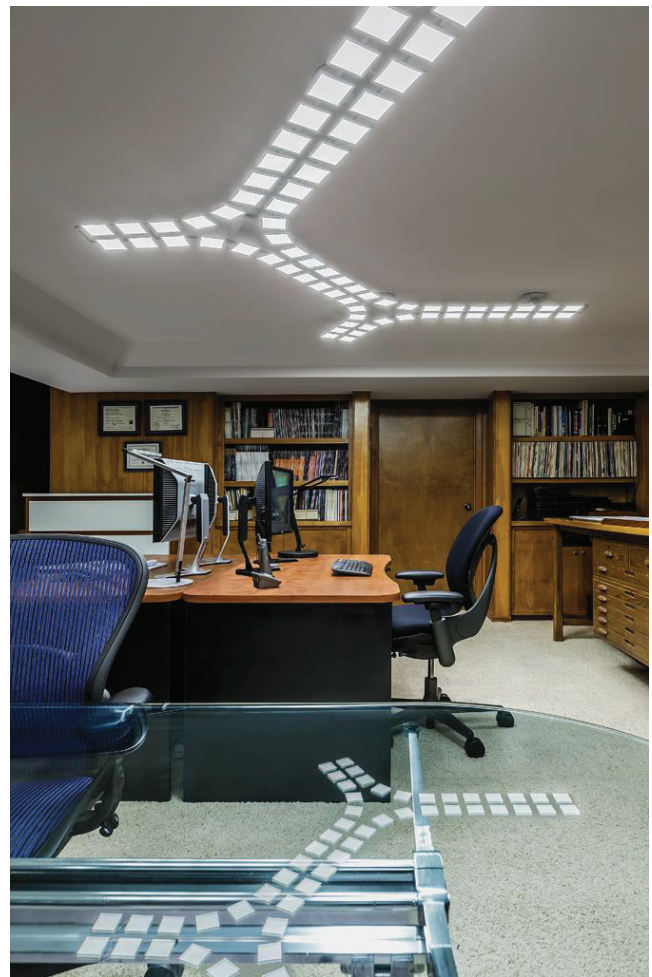

FIGURE 3.12 Example of organic light-emitting diode (OLED) panels. SOURCE: U.S. Department of Energy, “Gateway Demonstrations: OLED Lighting in the Offices of Aurora Lighting Design,” March 2016. Image courtesy of Acuity Brands.

Furthermore, current adoption of OLEDs in luminaires, mostly in custom-design and specialty lighting applications, is limited due to the high cost of OLED panels and insufficient demand. Custom-installed OLED lighting demonstration products such as DOE's Gateway Demonstrations (Figure 3.12) have been implemented to assess the viability of OLEDs as an alternative light source. A recently completed Gateway project (OLED lighting in the offices of Aurora Lighting Design, Ltd., March 2016) provides excellent light quality, eliciting comments from occupants such as "soft," "inviting," "desirable uniformity," and "comfortable." The project also revealed several performance issues, such as premature failure of some OLED panels due to electrical short, drive incompatibility, and related flickering—evidence that the OLED lighting industry is still in its early stages. *The high cost of OLED panels remains the key hurdle encountered in OLED lighting business today.*

Lifetime Issues

Achieving long shelf lifetimes requires assurance that the encapsulation scheme is sufficiently robust. This problem has been adequately solved for OLED displays, and approaches used for displays are expected to be of value for OLED SSL. Encapsulation approaches used in manufacturing include (1) glass to glass hermetic seals, (2) incorporation of desiccants inside the display panel, (3) thin-film encapsulation including atomic layer epitaxy (ALE), and (4) alternating soft/hard multilayered overcoat. The adoption of a specific approach for the thinner panels of OLED lighting will be cost driven.

Achieving a long operating lifetime principally relies upon a reduced current density through the OLED device, with a consequent reduction of electrochemical reactions (exciton-polaron interactions). The key means of reducing current density include (1) increasing the electroluminescence efficiency through molecular design and careful optimization of the device architecture; (2) improvement in light out-coupling efficiency, including the use of both internal and external light extraction layers, and preferred chromophore orientation; and (3) implementation of tandem device structures with multiple emitter units.

The short lifetime of blue emitters relative to green and red emitters is a major performance issue for OLED SSL products. Green and red emitters based on phosphorescent materials are commonly used in today's OLED display and SSL products; however, there is a lack of blue phosphorescent emitters that have sufficiently long lifetimes. Therefore, *fluorescent* emitters are used in the blue spectral range, which are not as efficient as phosphorescent emitters (see Box 3.B.1 in Annex 3.B). This limits the overall OLED luminous efficiency. For OLED SSL, the color balance between blue, green, and red emitters that is needed to produce white light of a specific color temperature is achieved by utilizing a tandem structure (see Annex 3.B). This incorporates a blue fluorescent OLED stacked with a phosphorescent yellow

OLED, emitting both green and red. By this means, the lifetime of white OLEDs has been significantly improved, and OLED SSL product lifetime (L_{70}) rated at 40,000 hours has been produced for rigid OLED product panels at an initial surface brightness of 3,000 cd/m² or equivalent light output of 9,425 lm/m². L_{95} of 5,000 hours at similar light output has been measured.

Manipulation of the tandem structure to include more than one blue stack provides a pathway to further improve the lifetime of the white OLED, and this also allows shifting the white spectrum to a higher color temperature. However, the lack of stable phosphorescent emitters has placed a limit of only about 40-60 lm/W on the luminous efficacy of these current OLED SSL products.

Best Research Results for OLED Lighting Panels

Achieving power efficient white OLEDs requires high internal quantum efficiency, low operating voltage, and high light out-coupling (extraction) efficiency. While internal quantum efficiencies in OLEDs have already approached 100 percent (Uoyama et al., 1998; Wang and Ma, 2010; Baldo et al., 1998), light out-coupling, which can be as low as 20 percent in conventional OLED structures, remains a primary challenge. The examples below show some recent, excellent performance in both efficacy and light-extraction from the R&D sector.

OLED lighting has achieved an efficacy of 133 lm/W in laboratory panels (10 cm × 10 cm) from Panasonic, 97 lm/W in development panels (10 cm × 10 cm) from LG, and 40 to 60 lm/W in product panels (up to 300 cm × 300 cm) from LG and other vendors. It should be noted that because the OLED is a diffuse surface emitter, the brightness of the surface is independent of the viewing angle, and the efficacy measured for an OLED "bulb" or panel may be or may not be equivalent to luminaire efficacy, depending on the luminaire design. Some further descriptions of those panel results are given below.

Panasonic has employed a novel high-index-of-refraction ($n = 1.8$) substrate together with high-index microstructure to carry out the light-outcoupling. A schematic of the device is shown in Figure 3.13 (Yamae et al., 2014). The panel incorporates all phosphorescent RGB emitters and operates with the highest reported values of EQE (56 percent per unit), as well as the highest efficacy reported, 133 lm/W for a large (10 cm × 10 cm) panel. The estimated L_{50} is greater than 150,000 hours.

LG's panel incorporates a hybrid design with fluorescent (blue) and phosphorescent (red and green) emitters, a dual extraction layer: one internal and one external (Jang et al., 2015). A pixelated anode (1 mm²/pixel) helps to eliminate electrical shorts and panel failures. The efficacy of this panel was 97 lm/W, with a measured L_{95} of 4,200 hours and a projected L_{70} of 40,000 hours. A schematic of the OLED structure is shown in Figure 3.14.

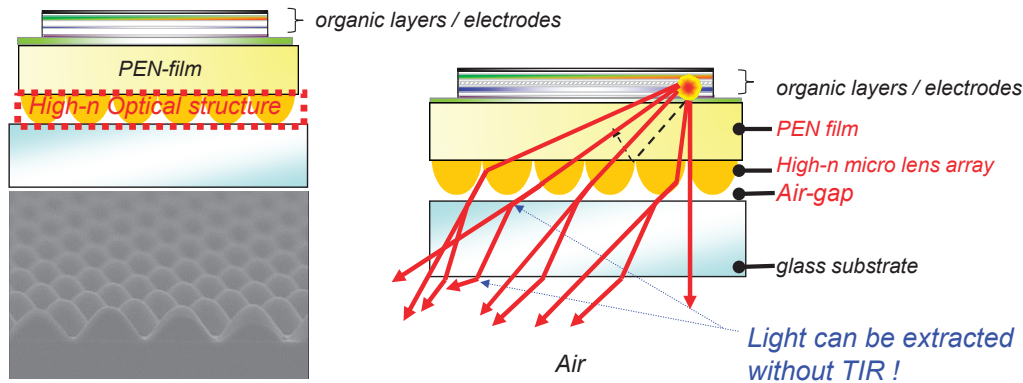

FIGURE 3.13 Light extraction scheme for a Panasonic panel, using (left) high-index substrate and (right) high-index microstructure; both external. SOURCE: K. Yamae, H. Tsuji, V. Kittichungchit, N. Ide, and T. Komoda, 2013, High-performance white-OLED devices for next-generation solid-state lighting, *SID Information Display* 29(5):38-44, September/October. ©2014 Society for Information Display.

Novel Approaches to Enhanced OLED Performance

The research community has also found approaches that quite naturally incorporate light out-coupling structures into the OLEDs. As shown in Figure 3.15, incorporation of nanostructures using soft-lithographic nano-printing for both internal and external light extraction in an OLED device has resulted in 54.6 percent EQE with 123.4 lm/W at 1,000 cd/m² (Ou et al., 2014). Other work has shown the benefits of aligning the molecular emitters for enhanced outcoupling of light through the substrate, resulting in improvements in external quantum efficiency (Kim et al., 2013). Consequently, new emitters have been developed, including blue hosts and dopants with molecular geometries that favor horizontal alignment (Kuma and Hosokawa, 2014).

FINDING: Major technological issues remain in improving the efficiency and performance of OLEDs, including efficient light extraction and reduced lifetime in the blue emitters. There is enough basic understanding of these issues to make progress in these areas. Some of the considered solutions have an important dependence on future manufacturing choices.

Challenges and Promises for OLEDs

Excellent progress has been made in achieving high OLED efficacy and long operational lifetimes in OLED panels for lighting applications. OLED panels as large as 320 cm × 320 cm are commercially available, with a tandem device structure and an integrated light extraction layer. These panels are rated at 60 lm/W and 40,000 hours. Efficacy as high as 133 lm/W has been demonstrated in the laboratory with further improvements in the light extraction scheme. Thin and lightweight OLED panels on plastic substrates with performance to OLED on glass are being produced,

Cathode
Phosphorescent unit
CGL
Fluorescent unit
CGL
Phosphorescent unit
HIL
TCO
Light extraction layer
Glass
Light extraction film

FIGURE 3.14 Hybrid fluorescent and phosphorescent three-unit tandem organic light-emitting diode (OLED), including two interconnecting layers (CGLs). The structure has one internal light-extracting layer and one external light-extracting layer. NOTE: HIL = hole injection layer; TCO = transparent conductive oxide. SOURCE: S. Jang, Y. Lee, and M.C. Park, 2015, OLED lighting for general lighting applications, *SID Symposium Digest of Technical Papers* 46(1):661-663. ©2015 Society for Information Display.

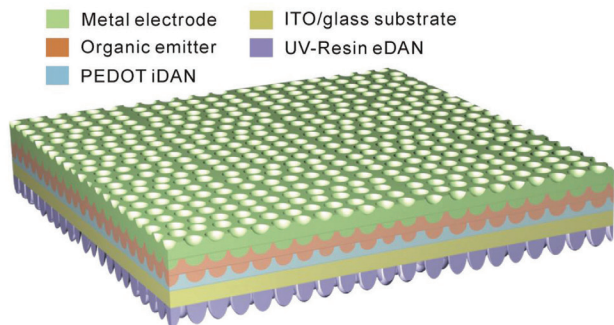

FIGURE 3.15 Schematic showing both internal and external scattering layers produced by soft-lithographic nano-imprinting. SOURCE: Q.-D. Ou, L. Zhou, Y.-Q. Li, S. Shen, J.-D. Chen, C. Li, Q.-K. Wang, S.-T. Lee, and J.-X. Tang, 2014, Extremely efficient white organic light-emitting diodes for general lighting, *Advanced Functional Materials* 24(46):7249-7256. © 2014 WILEY-VCH Verlag GmbH & Co. KGaA, Weinheim.

thus offering a new opportunity in the design of luminaires. However, the cost of OLED panels today remains too high (relative to LED products) to be a viable solution for general lighting applications. Current OLED panels are primarily used for decorative or specialty luminaires where the cost is determined by the luminaire’s design or unique features (thin, light, curvy, transparent), rather than practical utility. As such, the adoption of OLEDs for lighting has so far been minimal and will remain so until the cost of manufacturing OLED panels is significantly reduced. The long-term viability of OLEDs for SSL can only be established after the critical issues of manufacturing have been confronted and assessed.

FINDING: The luminous efficacy achieved in OLED lighting products is in the range of 40-60 lm/W, which is about a factor of two below that of general LED lighting products. This makes current OLED lighting products uncompetitive for general lighting applications.

SUMMARY AND COMPARISON OF LED AND OLED SSLS

Since the 2013 NRC report, LED and OLED SSL technologies have made substantial progress in demonstrated efficacies. Indeed, the widespread insertion of LED-based SSL has catalyzed a wealth of new lighting-based applications, as well as demands for higher quality of lighting. The development of OLED manufacturing for display technologies can provide substantial leverage for progress in the materials and performance of OLEDs for lighting, and there has been progress in providing commercially available OLED panels for lighting, with high efficacy and long operational lifetimes.

However, the costs of such panels are substantially higher than for LED SSL counterparts (Table 3.1), and the adoption of OLEDs for lighting has thus far been minimal.

Although there has been tremendous progress in the core technologies of both LEDs and OLEDs, many of the fundamental technological challenges are still dominant today (e.g., LED droop at high current densities, unequal efficiencies for different LED wavelengths, light extraction efficiency for OLEDs). In the case of LEDs, a highly competitive market promotes “working around” the technological challenges where possible (e.g., operating multiple LEDs at lower current densities to avoid droop). In the case of OLEDs, the costs of a manufacturable technology severely limit the current demand for OLEDs in SSL.

It is imperative that investments continue to be made in addressing and ameliorating the core technological challenges; indeed, these improvements will be even more critical for SSL to meet the second wave demands of smart, ultra-efficient SSL.

FINDING: Major technological issues remain to improve SSL efficiency, in both LEDs and OLEDs. Although there is a better understanding of the underlying mechanisms and possible solutions, the costs of implementing those solutions may be too expensive for industry to consider action. DOE has wisely focused on R&D priorities for core technologies that address the key technological challenges for high-efficiency SSL. These investments are critical.

TABLE 3.1 Comparison of Lighting Sources by Various Metrics

	Fluorescent	LEDs	OLEDs
Efficacy (laboratory demo)		231 lm/W (cold white) 150 lm/W (warm white)	133 lm/W
Efficacy (commercial)	90 lm/W	100-120 lm/W (white)	65 lm/W (warm white)
Color rendering index	80-85	85 (white) 95 (warm white)	Up to 95
Form factor	Long or compact gas-filled glass tube	Point source high-intensity lamp	Diffuse source, thin, lightweight, transparent, flexible
Lifetime (hours)	20,000	50,000	40,000@3000 cd/m ²
Cost (\$/klm)	1.0	3.0	100-250

NOTE: LED = light-emitting diode; OLED = organic light-emitting diode.

RECOMMENDATION 3-1: The Department of Energy should continue to make investments in core technology improvements for solid-state lighting technologies, both light-emitting diodes and organic light-emitting diodes, and should also consider solutions that will ultimately allow low-cost implementation and embody risks that industry is not likely to take. Early-stage investment in *disruptive* technologies represents high risks that industry is not likely to take.

REFERENCES

- Baldo, M.A., D.F. O'Brien, Y. You, A. Shoustikov, S. Sibley, M.E. Thompson, and S.R. Forrest. 1998. Highly efficient phosphorescent emission from organic electroluminescent devices. *Nature* 395:151.
- David, A. 2015. "Top Ten Challenges for Solid-State Lighting #9-Brightness." March 13. http://www.soraa.com/blog_entries/38.
- DOE (U.S. Department of Energy). 2016. *Solid-State Lighting R&D Plan*. DOE/EE-1418. Washington, D.C. May.
- Hurni, C.A., A. David, M.J. Cich, R.I. Aldaz, B. Ellis, K. Huang, A. Tyagi, R. DeLille, M.D. Craven, F.M. Steranka, and M.R. Krames. 2015. Bulk GaN flip-chip violet light-emitting diodes with optimized efficiency for high-power operation. *Applied Physics Letters* 106:031101.
- Jang, S., Y. Lee, and M.C. Park. 2015. OLED lighting for general lighting applications. *SID Symposium Digest of Technical Papers* 46(1):661-663.
- Kim, S.-Y., W.-I. Jeong, C. Mayr, Y.-S. Park, K.-H. Kim, J.-H. Lee, C.-K. Moon, W. Brütting, and J.-J. Kim. 2013. Organic light-emitting diodes with 30% external quantum efficiency based on a horizontally oriented emitter. *Advanced Functional Materials* 23(31):3896-3900.
- Kuma, H., and C. Hosokawa. 2014. Blue fluorescent OLED materials and their application for high-performance devices. *Science and Technology of Advanced Materials* 15(3):034201.
- Ou, Q.-D., L. Zhou, Y.-Q. Li, S. Shen, J.-D. Chen, C. Li, Q.-K. Wang, S.-T. Lee, and J.-X. Tang. 2014. Extremely efficient white organic light-emitting diodes for general lighting. *Advanced Functional Materials* 24(46):7249-7256.
- Tsao, J., M. Crawford, M. Coltrin, A. Fischer, D. Koleske, G. Subramania, G.T. Wang, J.J. Wierer, and R.F. Karlicek, Jr. 2014. Toward smart and ultra-efficient solid-state lighting. *Advanced Optical Materials* 2(9):809-836.
- Uoyama, H., K. Goushi, K. Shizu, H. Nomura, and C. Adachi. 2012. Highly efficient organic light-emitting diodes from delayed fluorescence. *Nature* 492:234-238.
- Wang, Q., and D. Ma. 2010. Management of charges and excitons for high-performance white organic light-emitting diodes. *Chemical Society Reviews* 39: 2387.
- Weisbuch, C., M. Piccardo, L. Martinelli, J. Iveland, J. Peretti, and J.S. Speck. 2015. The efficiency challenge of nitride light-emitting diodes for lighting. *Physica Status Solidi* 212:899-913.
- Wierer, J., and J. Tsao. 2015. Advantages of III-nitride laser diodes in solid-state lighting. *Physica Status Solidi A* 212(5):980-985.
- Yamae, K., V. Kittichungchit, N. Ide, M. Ota, and T. Komoda. 2014. Distinguished paper: Realization of outstandingly high efficacy white OLED by controlling evanescent mode and wide angular incident light. *SID 2014 Digest* 45(1):682-685.

ANNEX 3.A AN LED PRIMER

Introduction

Semiconductor light emitting diodes (LEDs) are a special kind of electronic device, which emit light upon the application of a voltage across the device. Silicon (Si) is probably the best-known semiconductor material, and the basis of the integrated circuits that underlie the fast and compact electronic devices, such as computers and cell phones, that are so critical to our daily lives. LEDs are based on a semiconductor material comprised of several different elements. This material is known as a compound semiconductor. The tremendous power of semiconductors lies in their ability to take on a wide range of conductivities, from metallic to insulator. This is brought about by “doping” the semiconductor with other elements that will donate either positively or negatively charged carriers to achieve a desired conductivity.

Semiconductors can also absorb and emit light, and the relevant wavelengths are related to the bandgap of the semiconductor (see Box 3.A.1). The general process for light emitted in this manner is referred to as electroluminescence. The first high-efficiency light-emitting devices were developed in the 1960s utilizing gallium arsenide (GaAs), aluminum gallium arsenide ($\text{Al}_x\text{Ga}_{1-x}\text{As}$), gallium phosphide (GaP) and gallium arsenide phosphide ($\text{GaAs}_x\text{P}_{1-x}$) (Hall et al., 1962; Nathan et al., 1962; Pankove and Massoulié, 1962; Woodall et al., 1972; Herzog et al., 1969). GaAs and AlGaAs LEDs produced light with infrared wavelengths, ~850 nanometers (nm), while the gallium phosphide-based LEDs produced light in the red and green wavelengths. In the early 1990s efficient blue LEDs based on III-nitride materials began to appear based on the work of Akasaki et al. (1992) and Nakamura et al. (1994). (The III refers to elements in the third column of the periodic table, indicating that these LEDs can be comprised of alloys of aluminum nitride (AlN), gallium nitride (GaN) and indium nitride (InN)). The bandgaps of these III-nitrides produce light emission across a range of wavelengths spanning the infrared to ultraviolet parts of the spectrum. The III-nitride LEDs have had an unusually rapid development and huge impact on appearance of SSL. Although the first GaN LED was reported by Pankove et al. (1971), almost two decades transpired before substantial further progress was made by Akasaki and Nakamura. Amano and Akasaki demonstrated that high crystal quality GaN could be grown by MOCVD using a novel low-temperature buffer (Amano et al., 1986) and later succeeded in using electron beams to activate Mg receptors (Amano et al., 1989). In 1992, Nakamura, working at Nichia, developed an industrially robust process for p-doping of GaN that led to the first high-brightness blue LEDs. This provided the understanding of the mechanisms that had limited the conductivity of p type material and allowed for the first time the fabrication of low-voltage p-n junction LEDs and eventually led to the commercialization of high-brightness blue and white LEDs for

SSL. The wider bandgaps of the III-nitrides enabled efficient LEDs emitting light at blue wavelengths, which together with green and red LEDs provided the basis for white light as well as full-color displays. The nitride blue emitters can also be coupled with phosphors to generate white light, which is currently the dominant approach to an SSL technology. The later introduction of blue LEDs, compared to their green and red counterparts, is the result of materials issues that are still of importance today: the lack of a well-matched material (substrate) upon which to form the LED structures, and some difficulties in controlling the electrical properties of the material. Nonetheless, the III-nitride materials have been pivotal in the success of inorganic SSL, and thus the committee will focus here on LEDs formed from those materials. There are several good reviews of LED device technology (see, for example, Schubert (2006) as well as III-nitride materials technology in Pankove and Moustakas (1998).

BOX 3.A.1 Light Emission Mechanism

Figure 3.A.1.1 gives a simple description of the basic light-emission process. Electrons fill up energy states in a valence band, which is separated in energy from a conduction band by an energy gap, with energy E_g (where there are generally no allowed states in which electrons can reside). Providing energy to an electron in the valence band can promote that electron to the higher-energy conduction band, also creating a (hole) (lack of electron) in the valence band. The electron can subsequently return to its lower-energy state: in *radiative recombination*, the electron returns to the valence band and releases a photon with the energy of the photon approximately equal to the energy E_g . In a light-emitting diode (LED), radiative recombination is the desirable outcome for an “energized electron,” but there are also numerous non-radiative recombination processes where the electron or hole may be trapped at defects or imperfections in the material. Such imperfections limit the efficiency of the light generation and, therefore, of the LED.

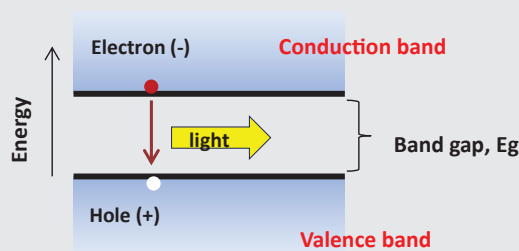

FIGURE 3.A.1.1 Light emission process.

The LED Device Structure

The basis of the LED device is a p-n junction diode, shown schematically in Figure 3.A.1. As the name implies, there is a junction between the N-type material (rich in electrons) and P-type material (rich in holes). Under forward bias (positive voltage applied to the P-region and negative voltage applied to the N region) large numbers of electrons are injected into the N region and large numbers of holes are injected into the P region.

Current flows in the device and the large number of injected electrons and holes can combine radiatively, producing significant light emission. The basic structure is modified in actual LEDs to (1) improve the efficiency of injection of electrons and holes and to (2) “localize” the electrons and holes and improve the likelihood of radiative recombination. This localization is accomplished by introducing multiple quantum wells (MQWs) in the region of the junction: the MQWs are indicated in the inset of Figure 3.A.1. These are thin slivers of lower bandgap-materials that, as their name implies, serve as wells that confine pools of electrons and holes to increase the probability that they will recombine radiatively. The multiplicity of the quantum wells ensures greater light output. Figure 3.A.2 provides some more detail of the multiple quantum well structures. Now electrons injected into the N region, and holes injected into the P region can be localized within the quantum wells until they recombine to emit light. Figure 3.A.2 also suggests that under conditions of high current injection (a large density of electrons and holes), the quantum wells may completely fill up, localization no longer takes place, and radiative recom-

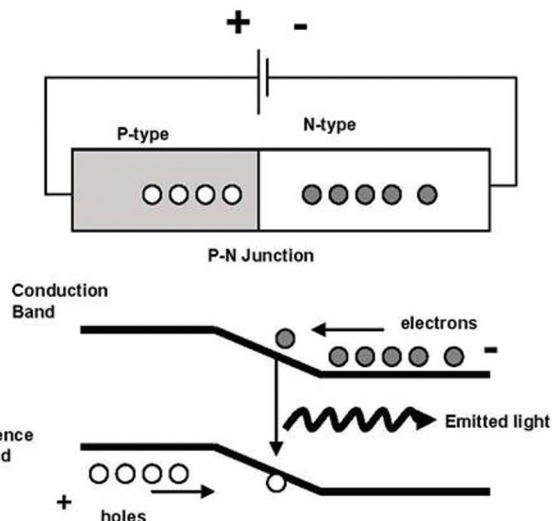

FIGURE 3.A.1 Schematic of p-n junction diode.

ination, or the emission of light, becomes inefficient. The over-filling of the quantum wells is related to the problems of droop at high current densities.

The external view of the typical LED structure is given in Figure 3.A.3, showing the N-type GaN, the InGaN quantum wells, and the P-type GaN. Most GaN LED devices are formed on a sapphire substrate through a process termed Metal Organic Chemical Vapor Deposition (MOCVD). Typically, one 4-inch diameter sapphire wafer can produce 5,000 individual devices or “dies.” The 16 percent mismatch in natural lattice size between the sapphire substrate and

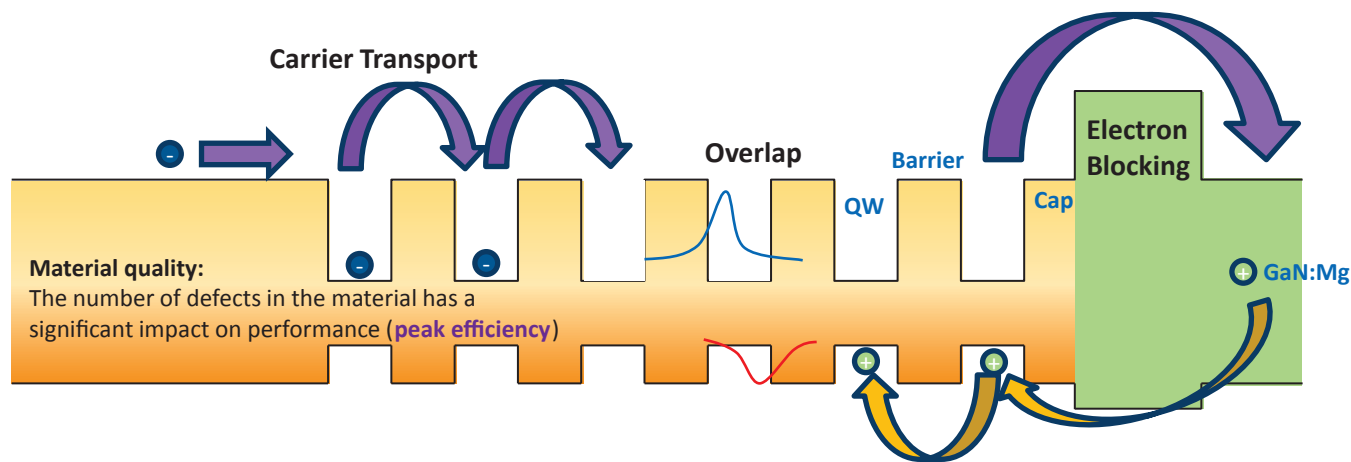

FIGURE 3.A.2 Schematic of a multiple quantum well (QW) region, showing injection of electrons (in purple, from left) and holes (in yellow, from right). The desired goal is recombination of electrons and holes to form photons. The schematic suggests the ways in which electrons and holes may be lost from the structure or otherwise not be able to recombine. SOURCE: Image courtesy Lumileds, Epitaxy Technology Group.

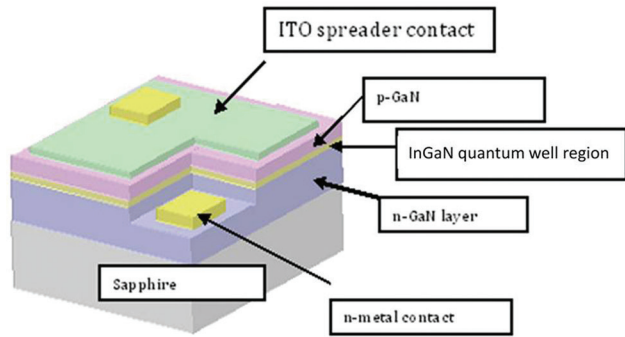

FIGURE 3.A.3 A typical GaN light-emitting diode (LED) chip.

the GaN overlayers has important consequences on device performance and on the uniformity of the dies grown from a single wafer. In order to connect the device to the outside world, metal contacts must be deposited by evaporation on the N and P regions. Figure 3.A.3 shows these metal contacts, as well as the transparent and conductive indium tin oxide (ITO) layer that extends the top-side electrical contact over the device surface. Both the sapphire substrate and the ITO spreader contact are transparent to the emitted light, as is necessary for the light to leave the device. High-quality electrical contacts are important to reduce loss due to resistance (R) to current flow (I) in the contact region. This is even more important when the device is operated at high currents or current densities, since loss of power due to resistive heating scales as I^2R . In the III-nitride materials, it is a challenge to dope the materials to a sufficient level so that resistances are low, particularly for P-type materials. The formation of

the device structure shown in Figure 3.A.3 is just a starting point for the fabrication of the final solid-state “light bulb.” An individual device must be further “packaged,” as shown in Figure 3.A.4, to better control its chemical, thermal and electrical environment and to better integrate it into the final luminaire.

The LED Module

The LED package is the structure in which the LED chip is mounted and through which access to the LED terminals is provided. It is an important part of the finished device. The package serves many functions: (1) the package passivates or protects the active semiconductor material from degradation due to the environment (principally moisture); (2) the package integrates an optical lens structure which determines the optical emission pattern of the structure; (3) the package removes heat from the device, protecting against degradation due to overheating; (4) the package protects the device from Electro Static Discharge (ESD) failure. The packaging processes include placement of the device in the chip carriers, attachment of the optical lens, as well as electrical and optical device testing and “binning.” Because of the variability in the color accuracy, color quality and color stability, each device must be individually tested and placed in performance bins. In addition, if phosphor coatings are used in connection with the LED to control the output color, the phosphor must be added to the device or package.

A schematic of a typical LED package is shown in Figure 3.A.4. A major element of the package is the lens/encapsulate assembly. The lens is integrated with a polymer encapsulation material which entirely encloses the chip. The plastic lenses/encapsulate material must have the required optical properties for light focusing as well be able to with-

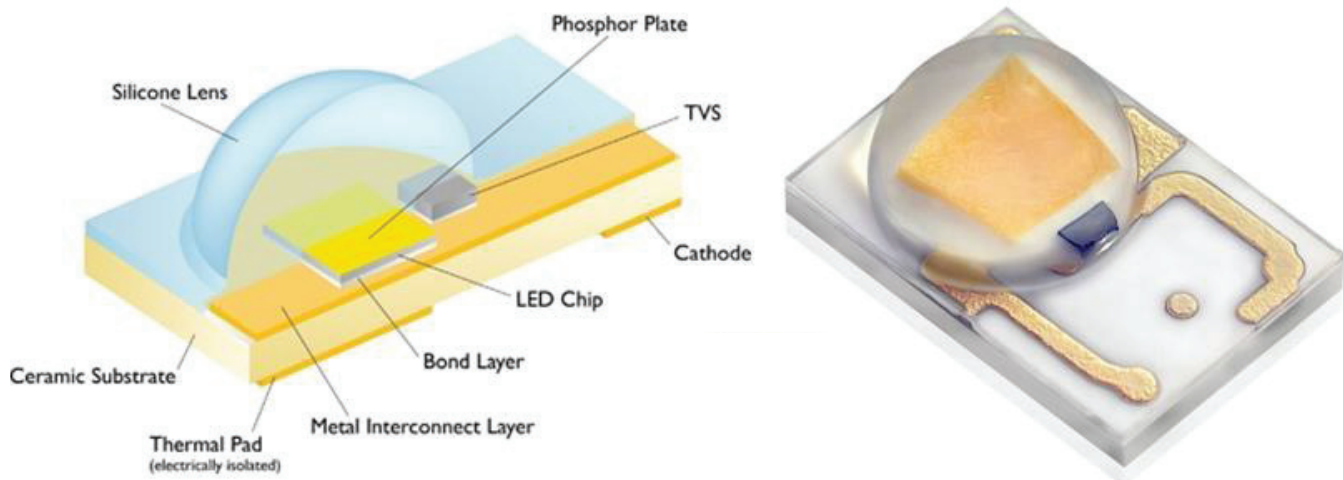

FIGURE 3.A.4 Schematic of a light-emitting diode (LED) module. SOURCE: Lumileds.

stand constant optical radiation and elevated operating temperatures without loss of transparency. The LED semiconductor chip or “die” is attached to a reflector cup (not shown explicitly in the Figure 3.A.4) which redirects all light to the plastic lens structure. The LED is attached to the reflector cup with a conductive epoxy. This process step is called die attachment. The conductive epoxy is usually loaded with silver (Ag) in order to increase the optical reflection. The reflector cup also contains the phosphor material, which is used to generate the additional wavelengths required for white light production. The package base produces two leads, which connect the LED to the outside world. Typically one package lead is integrated with the base of the package. The base of the package in turn is connected via conducting materials and conductive epoxy to one side of the LED die. The opposite side of the LED die is connected to the cathode by a second electrically isolated gold bond wire. The “silicon submount” structure shown in the figures incorporates devices that limit the build-up of static charge (“static electricity”) which could destroy the LED. The submount structure is attached to a copper slug, which serves as an efficient heat sink, preventing the loss of efficiency that occurs at very high temperature operation. This is necessary to maintain device reliability.

Metrics of Device Performance

Efficiency is an important metric of LED device performance, and some insights into efficient operation can be gained by tracing the life-cycle of the LED operation beginning with the injection of electrons and holes, shown in Figure 3.A.2, leading to the generation of photons within the device, and culminating with the emission (or extraction) of the photons from the device. A simple summary of the total external quantum efficiency (EQE, or η_{EQE}) of an LED can be expressed as

$$\eta_{EQE} = \eta_{IQE} \cdot \eta_{out}$$

where η_{IQE} is the internal quantum efficiency (IQE), and η_{out} is the outcoupling efficiency, which is discussed below.

Internal Quantum Efficiency

Not all electrons and holes that are injected into the LED (e.g., from a battery) will produce photons: for example, defects in the LED material can trap an electron or a hole, and prevent the formation of a photon. The percentage of photons generated, relative to current (of electrons or holes) that is injected into the device is reflected in the IQE. η_{IQE} can be maximized by using quantum well structures as described above, by utilizing defect-free semiconductor material, and by ensuring high-quality, very low resistance metal contacts to the device. η_{IQE} also sensitively depends on the quality of the LED material. Because the quantum well composition and strain varies with the desired emission wavelength, η_{IQE} varies with wavelength. At present, there are still large

differences in the power conversion efficiencies of blue (66 percent), green (22 percent) and red (44 percent) LEDs (DOE, 2016, p. 145), equal efficiency of LEDs at all colors is important, and further improvements towards 100 percent η_{QE} will require far better control of the material defects.

Current and Thermal Droop

As described in the section “Key Core Technology Challenges for LEDs,” two of the most important issues holding back efficiency at high illumination levels is the droop in efficiency as the LEDs is driven at higher currents and the effect of temperature. These issues are known in the industry as “current droop” and “thermal droop.” A fuller discussion of these factors is also given in “Key Core Technology Challenges for LEDs.”

Outcoupling Efficiency

Once the photons have been formed in the LED structure, care must be taken to ensure that they will exit the device. The ratio of photons leaving the device to the number generated within the device is called the outcoupling efficiency, or light extraction efficiency. Because the LED material has a higher index of refraction ($n \sim 2.5$) than air ($n = 1$), most photons incident on the GaN-air interface will be internally reflected and trapped within the LED structure or absorbed (lost) by other materials comprising the device (see Figure 3.A.5). A thin metal film can serve as a mirror to direct the light out through the “front surface” of the LED. The internal reflection and trapping of the light can be mitigated by forming a rough, rather than smooth top LED surface; one way of achieving this is through the immersion of the device structure in a simple wet chemical etchant (Fujii et al., 2004). Such techniques can improve the extraction efficiency from a few percent to values of 80 percent (Krames et al., 2007).

External Power Efficiency

Finally, the external power efficiency (η_p) is defined as the ratio of the total optical power output of the LED to the electrical power input. Low resistive power loss, high η_{IQE} and good design to maximize η_{out} produce high power efficiency in LEDs. Maximizing the power efficiency not only increases the efficacy of the LED but also reduces the heat removal problem.

References for Annex 3.A

- Akasaki, I., H. Amano, K. Itoh, N. Koide, and K. Manabe. 1992. GaN-based ultraviolet/blue light-emitting devices. *Institute of Physics Conference Series* 129:851-856.
- Amano, H., N. Sawaki, I. Akasaki, and Y. Toyoda. 1986. Metalorganic vapor-phase epitaxial-growth of a high quality GaN film. *Applied Physics Letters* 48(5):353-355.

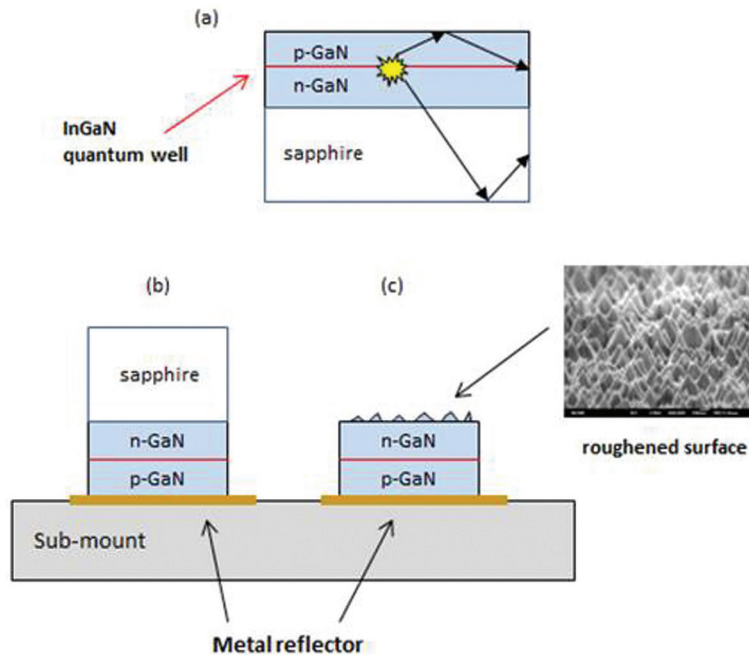

FIGURE 3.A.5 Improving light extraction efficiency. (a) Much of the light emitted from the quantum well is internally reflected (not extracted). (b) Flipping the light-emitting diode (LED) and placing it above a reflective surface helps to direct the light outwards. (c) Removing the sapphire substrate and then roughening the top of the LED surface. NOTE: p-GaN is P-type (i.e., positive) gallium nitride material (rich in holes); n-GaN is N-type (i.e., negative) gallium nitride material (rich in electrons).

Amano, H., M. Kito, K. Hiramatsu, and I. Akasaki. 1989. P-type conduction in Mg-doped GaN treated with low-energy electron-beam irradiation (Leebi) [in English]. *Japanese Journal of Applied Physics Part 2-Letters* 28(12):L2112-L14.

DOE (U.S. Department of Energy). 2016. *Solid-State Lighting R&D Plan*. DOE/EE-1418. Washington, D.C. May.

Fujii, T., Y. Gao, R. Sharma, E.L. Hu, S.P. DenBaars, and S. Nakamura. 2004. Increase in the extraction efficiency of GaN-based light-emitting diodes via surface roughening. *Applied Physics Letters* 84(6):855-857.

Hall, R.N., G.E. Fenner, J.D. Kingley, T.J. Soltys, and R.O. Carlson. 1962. Coherent light emission from GaAs junctions. *Physics Review Letters* 9:366.

Herzog, A.H., W.O. Groves, and M.G. Craford. 1969. Electroluminescence of diffused GaAs_{1-x}P_x diodes with low donor concentrations. *Journal of Applied Physics* 40:1830.

Krames, M.R., O.B. Shchekin, R. Mueller-Mach, G.O. Mueller, L. Zhou, G. Harbers, and M.G. Craford. 2007. Status and future of high-power light-emitting diodes for solid-state lighting. [in English]. *Journal of Display Technology* 3(2):160-175.

Nakamura, S., T. Mukai, and M. Senoh. 1994. Candela-class high-brightness InGaN/AlGaIn double-heterostructure blue-light-emitting diodes. *Applied Physics Letters* 64:1687.

Nathan, M.I., W.P. Dumke, G. Burns, F.H. Dill Jr., and G.J. Lasher. 1962. Stimulated emission of radiation from GaAs P-N junctions. *Applied Physics Letters* 1(3):62-64.

Pankove, J., and M.J. Massoulié. 1962. Injection luminescence from GaAs. *Bulletin of the American Physical Society* 7:88.

Pankove, J. I., and T. D. Moustakas. 1998. *Gallium Nitride (GaN) I*. Semiconductors and Semimetal Volume 50 (R.K. Willardson and E.R. Weber, eds.). New York: Academic Press.

Pankove, J.I., E.A. Miller, and H.E. Berkeyheiser. 1971. GaN electroluminescent diodes. *RCA Review* 32(3):383.

Schubert, E.F. 2006. *Light-Emitting Diodes*. Second ed. New York: Cambridge University Press.

Woodall, J.M., R.M. Potemski, S.E. Blum, and R. Lynch. 1972. Ga_{1-x}Al_xAs LED structures grown on GaP substrates. *Applied Physics Letters* 20(10):375.

ANNEX 3.B AN OLED PRIMER

Introduction

Organic light emitting devices (or OLEDs) are a new source of illumination wherein light is emitted uniformly over a large planar surface. They are primarily deployed today in very large numbers for displays on handheld appliances such as smart phones. The excitement surrounding OLED technology stems from several unique aspects of its manufacture and performance. They are inherently ultrathin film devices that can be deposited on any smooth substrate such as glass, flexible metal foil, or even plastic, and the devices themselves have very high performance: 100 percent internal quantum efficiency, custom tunable color from the blue to the near infrared, and extremely low temperature rise even when operated at very high brightness. In contrast to the inorganic semiconductor materials used for LEDs, organic materials are predominantly carbon-based, much the same as inks used in printing, or dyes used to color fabrics. Hence, in principle they are abundant, inexpensive and may have limited negative environmental impact. In addition, the materials used in fabricating OLEDs are used in very small quantities, and are deposited over large areas using low energy consumption processes given their low sublimation temperatures.

The OLED Device Structure and Operation

The first organic light emitting device was demonstrated in the 1960s by Pope et al. (1963), and later by Helfrich and Schneider (1965). Sandwiching the organic material, anthracene between contact electrodes, blue light was emitted at a relatively high efficiency (a few percent). Unfortunately, the voltage required was very high (~500 V). This situation changed dramatically in 1987 with the first low-voltage OLED. With an efficiency of approximately 1 percent, the voltage was dropped to <10 V, suggesting that a new and potentially efficient light source had been demonstrated (Tang and VanSlyke, 1987). While their first commercial applications of OLEDs have been in ultrathin, full color displays, their currently extremely high efficiency has led laboratories worldwide to explore their applicability as lighting sources.

A simplified OLED structure is shown schematically in Figure 3.B.1. In this diagram, the nomenclature used is typical of that used in OLEDs. Here, “ETL” is the organic electron transport layer that moves electrons from the cathode metal contact to the light emissive layer, or “EML.” This layer is typically composed of two different molecules, a charge conductive “host” into which is doped at very small concentration (~1 to 8 percent by weight) of a molecule that gives off light of the desired color (or wavelength), under excitation from electrons and holes in the device. This dopant is called the light emissive “guest.” The “HTL” is the

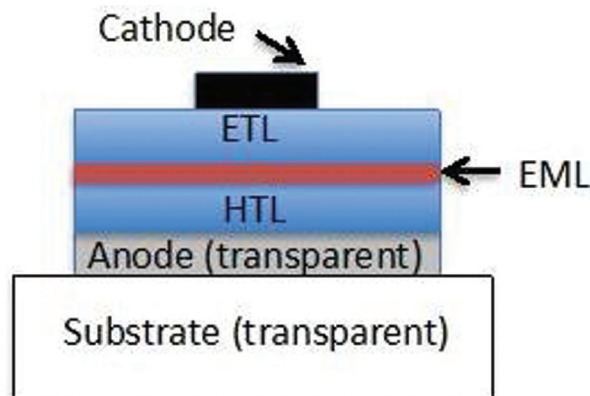

FIGURE 3.B.1 Archetype organic light-emitting diode structure. SOURCE: A.E. Willner, R.L. Byer, C.J. Chang-Hasnain, S.R. Forrest, H. Kressel, H. Kogelnik, G.J. Tearney, C.H. Townes, and M.N. Zervas, 2012, Optics and photonics: Key enabling technologies, *Proceedings of the IEEE* 100:1604. ©IEEE (2012). Reprinted, with permission from Proceedings of the IEEE.

hole transport layer whose purpose is to transport positively charged “holes” from the anode contact to the EML. The transparent conducting anode through which the light is viewed is invariably composed of indium tin oxide (ITO), and the cathode is a metal (such as aluminum doped with lithium) capable of forming an ohmic contact with the ETL for the efficient injection of electrons. Typical OLED structures used in high-efficiency and high-reliability applications are considerably more complex than the structure shown in Figure 3.B.1. However, in all cases, the total thickness of organic layers rarely exceeds 100 nanometers (1 nanometer = 10^{-7} centimeter). The committee also notes that in contrast to LEDs, OLEDs can be made integral to the luminaire or fixture, rather than being added to it, in contrast to all alternative lighting solutions. This structural adaptability provides new design possibilities for solid-state lighting.

The mechanism for light emission in organic thin film OLEDs (see Box 3.B.1) is fundamentally different than in inorganic semiconductor LEDs described earlier in this chapter. When an electron, and its oppositely charged counterpart, the hole, are conducted to the same molecule within the EML, they put the molecule into an “excited state.” This excitation is maintained for a brief period of time (from nanoseconds to microseconds). While it exists, the excitation can hop from molecule to molecule which are very densely packed within the EML. This mobile excitation (called an “exciton”) eventually decays by the recombination of the electron and the hole: i.e., the electron “falls into” the hole which is located on the same molecule as the electron. This decay process often emits light whose energy is equal to that of the difference in energies between the electron and hole. By changing the composition or structure of the molecule,

BOX 3.B.1 How Light Is Emitted in OLEDs

Shown in Figure 3.B.1.1 is a pictorial view of the light-emitting layer in an organic light-emitting diode (OLED). This layer is typically sandwiched between electron and hole transporting layers. The blue background represents the thin film that is comprised of a molecular species that transports the charges injected from contacts at the boundaries of the OLED itself. The red dots are the dopant molecules that are interspersed at low density within the charge transporting matrix. These dopants can either be fluorescent molecules or phosphorescent molecules. Phosphorescent molecules can produce devices with the highest internal quantum efficiency. A typical phosphor molecule is shown blown up in the lower left. It can be very inexpensive and is only used in trace amounts. Ultimately, it consists of carbon, nitrogen and hydrogen atoms (open circles) that are bonded together (lines) along with a heavy metal atom (typically iridium) in its center (red dot). Light emission occurs when an electron, injected from the cathode, travels to the same molecule as the hole (positive charge) injected from the anode. Light is then generated when the electron and hole (or exciton) recombines on the edges of the dopant molecule. This emission process is depicted by the yellow burst around the dopant molecule in the emitting region. By varying the structure of the molecule, the entire visible and near-infrared spectra can be accessed.

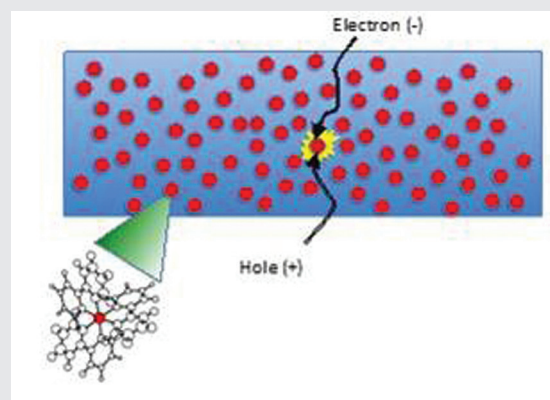

FIGURE 3.B.1.1 Pictorial view of the light-emitting layer of an organic light-emitting diode (OLED).

the wavelength (color) of light emission can be varied. In fact, only slight chemical modifications can result in the color emission being changed from the ultraviolet, through the blue and green, to the red. In all cases, the light emission can be extremely efficient (100 percent conversion of electrons to photons has been reported across the visible light spectrum).

Metrics of Device Performance

In a manner similar to the calculation of external quantum efficiency (EQE) of an inorganic LED, the EQE of an OLED depends on both an intrinsic efficiency, for the material and device, and an outcoupling or extraction efficiency.

$$\eta_{EQE} = \phi \cdot \gamma \cdot \eta_{out} \cdot \chi \quad (3.1)$$

where ϕ is the absolute efficiency of a molecule to emit light once excited, γ is the probability that every injected electron and a hole can simultaneously exist on a light-emissive molecule, η_{out} is the outcoupling efficiency to be discussed below, and χ is the ratio of emissive molecular excited states that an electron and hole can reside on in a single molecule to the total number of possible excited states. χ is also known as the excited state ratio. For the best emissive molecules, $\phi = 1$, which is often the case with state-of-the-art materials. Furthermore, $\gamma = 1$ in properly engineered device structures.

The power efficiency (η_P) of the light source is its most important operational parameter. Here the optical power out per the input electrical power is related to the quantum efficiency following:

$$\eta_P = \theta \eta_{EQE} \frac{V_\lambda}{V} \quad (3.2)$$

Here, θ is the overlap of the light source with the spectral sensitivity of the eye, and V_λ is related to the energy of the emitted photon. The operating voltage of the OLED is V : clearly the power efficiency decreases as V increases. For a given device geometry, the operating voltage is related to the device drive current and thus also has an important influence on the device lifetime.

In conventional OLEDs fabricated on glass substrates, through mechanisms similar to those in inorganic LEDs, much of the emitted light is trapped within the glass substrate, or absorbed in the layers that comprise the device (see Figure 3.B.2), resulting in an extraction or outcoupling efficiency of only ~20 percent. However, low-cost schemes have been reported that can increase this efficiency to 40 to 60 percent (see below). Nevertheless, one of the grand challenges facing OLEDs is how to extract more of the emitted light in a cost-effective and highly efficient manner. This is discussed further in the section “Novel Approaches to Enhanced OLED Performance,” above.

Finally, the excited state ratio is $\chi = 0.25$ for fluorescent emitting molecules, and $\chi = 1$ for phosphors, as will be discussed in the following section (Baldo et al., 1999). Putting all of the efficiencies together, it is demonstrated that $\eta_{EQE} = 20$ -60 percent in the very best cases. Even with these limitations, the power efficiency of phosphorescent white organic light emitting devices can exceed 150 lm/W, making them especially attractive for use as efficient lighting sources.

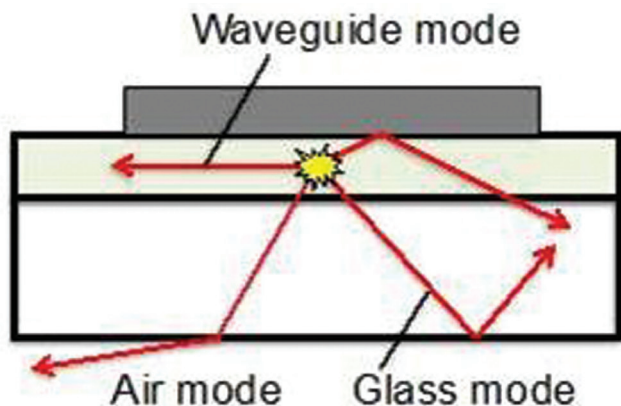

FIGURE 3.B.2 Illustration of the optical pathways taken by a photon following emission from a luminescent molecule (shown as yellow star).

Architectures for White-Light OLEDs (WOLEDs)

White light in OLEDs is generated by mixing red, green and blue emission from different regions of the OLED. Several schemes have been developed for OLED lighting applications that are both efficient and have a stable, predictable, and highly controllable white chromaticity. The highest performance is achieved using a variant of one of the three designs in Figure 3.B.3 depicts the striped white organic light emitting diode (WOLED), the fluorescent/phosphorescent (F/P) WOLED, and the stacked, or tandem WOLED. The latter design is most effective in achieving long lifetime and high brightness, and can be combined with the (F/P) design as well as others for illumination purposes.

Striped WOLEDs

This simple design places stripes of red (R), green (G), and blue (B) PHOLEDs (phosphorescent OLEDs) side-by-side. The R-G-B pattern is repeated on a very small scale so that the separate colors cannot be resolved by an observer. By injecting current into each stripe, the viewers will perceive the mixture of the three primary colors, which will appear white. An advantage of this design is that each of the three color elements can be separately optimized to emit with 100 percent internal efficiency, and variation of the current through each of the elements can be used to tune the color, from their constituent color to any desired white chromaticity. A disadvantage is the complexity of driving the WOLED with three different current sources.

F/P WOLEDs

This device is based on the recognition that approximately 25 percent of the color content of white light is blue. To achieve lower voltage operation and perhaps longer lifetime, this device uses a fluorescent blue segment, and harvests the remaining green and red excited states using phosphorescent molecular compounds. In principle, this particular device has the lowest drive voltage and hence highest efficacy of all alternative architectures. The F/P design can also be incorporated into stacked (tandem) and striped architectures. Hence, the device still achieves 100 percent internal quantum efficiency since all excitons are harvested by a combination of blue fluorescent dopants and red and green phosphors. Stacked WOLEDs (SOLEDs)

This compact design stacks two or three white emitting segments, with each segment separated by a very thin and transparent “charge generating layer.” In this case, a single

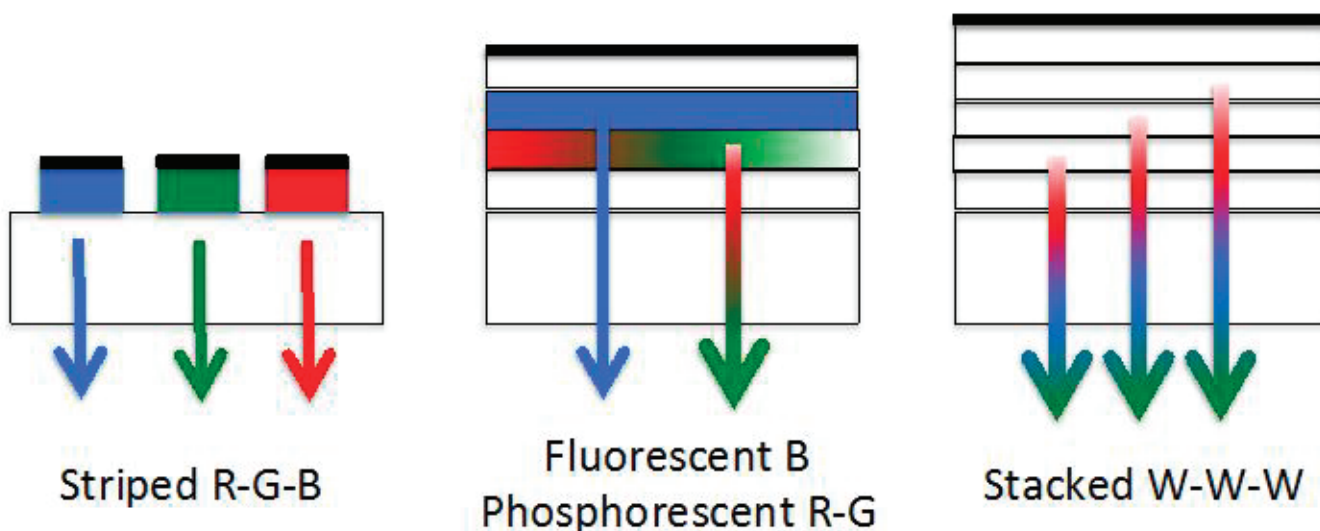

FIGURE 3.B.3 Three examples of white organic light-emitting diode designs.

injected electron can recombine with a positively charged hole in each segment, generating a photon. Thus, a 2 to 3 times higher quantum efficiency is achieved with this device compared to the other designs, but at 2 to 3 times higher voltage (where the multiplier is equal to the number of elements in the final stack). Hence, the efficacy of this device is no higher than that of the other designs shown, but there are significant benefits of increased device lifetime.

References for Annex 3.B

- Baldo, M.A., D.F. O'Brien, M.E. Thompson, and S.R. Forrest. 1999. The excitonic singlet-triplet ratio in a semiconducting organic thin film. *Physics Review B* 60:14422.
- Helfrich, W., and W.G. Schneider. 1965. Recombination radiation in anthracene crystals. *Physics Review Letters* 14(1965):229.
- Pope, M., H. Kallmann, and P. Magnante. 1963. Electroluminescence in organic crystals. *Journal of Chemical Physics* 38:2042.
- Tang, C.W., and S.A. VanSlyke. 1987. Organic electroluminescent devices. *Applied Physics Letters* 51:913.

4

SSL Applications

SOLID-STATE LIGHTING SYSTEMS

Solid-state lighting (SSL) products are *integrated systems* that consist of a number of subcomponents. Generally, these subcomponents include the following:

- A light-emitting diode (LED), an LED array, an integral lamp, or an organic light-emitting diode (OLED) panel;
- Secondary optics to control the distribution of the light;
- Heat sink, thermal management components, or thermal interface material; and
- Driver and control devices.

A very thorough discussion of the subcomponents, their performance, and needed areas of improvements was given in the 2013 NRC report *Assessment of Advanced Solid-State Lighting* (NRC, 2013), and some of the salient descriptions are included in the Annex 4.A. Important improvements remain for these SSL systems, particularly in regard to thermal managements and lighting control. Nevertheless, since the 2013 report, significant progress has been made in the design and manufacture of these systems, in terms of cost, efficacy, and compatibility with lighting controls. The applications described in this chapter, both for retrofit and emerging applications, will continue to demand increased energy efficiency, light quality, controllability, and reliability of these SSL systems.

As discussed in Chapter 2, the so-called “overnight potential” energy savings from retrofitting incandescent and fluorescent lamps in residential and commercial buildings is approximately 5 quadrillion British thermal units (quads), roughly 40 percent of the (source) energy consumed by lighting in the United States today. However, energy savings is not the only source of motivation for changing from legacy to SSL products. Light quality and the suitability of products for different applications also drive lighting design decisions.

CURRENT APPLICATIONS OF SSL

As discussed in Chapter 1, in 2015, 6.4 percent of the installed U.S. base of indoor lighting products were LED products, while outdoor lighting LED products accounted for 14 percent of the installed base. The first applications of LED products were for outdoor lighting because of the promise of a long life with subsequent reduced maintenance, and the total installed base of outdoor lighting represents less than 5 percent of the number of units in indoor lighting installations.

SSL is a growing technology and is now widely accepted by the design and commercial building industry, and is growing in popularity with the general public. During this relatively early stage of commercialization, most common SSL products are LED lamps and luminaires that replicate existing legacy form factors, such as medium screw-base lamps, recessed troffers, and cobra head-style¹ luminaires for street and roadway lighting.² These are used in similar applications as their legacy lamp predecessors, but with distinctly different appearances, such as heat sinking fins and multipoint light sources. Exceptions to this are retrofit LED lamps with medium screw-base that mimic the appearance of the incandescent filament of traditional lamps.³

Only in the last couple of years have new form factors been introduced to address lighting quality issues, such as reduced glare, diffuse distributions of emitted light, improved beam appearance, and color consistency. The use of light guides is gaining popularity, resulting in better optical control and reduced glare. Examples of LED products that use light

¹ So named because of the resemblance with the head of a cobra snake.

² See, for example, OVF LED Roadway Large Cobrahead website at http://www.cooperindustries.com/content/public/en/lighting/products/roadway_lighting/_182918.html.

³ See, for example, OSRAM, “LED Retrofit CLASSIC A,” https://www.osram.com/osram_com/products/lamps/led-lamps/consumer-led-lamps-with-filament-style-led-technology/led-retrofit-classic-a/index.jsp, accessed October 20, 2016.



FIGURE 4.1 Cree IG Series WaveMax. The luminaire uses optical waveguides to provide low-glare illumination. SOURCE: Cree, “LED Parking Structure: IG Series Outdoor Lighting,” <http://lighting.cree.com/products/outdoor/parking-structure/ig-series>, accessed August 9, 2016.

guides include indirect luminaires for commercial interiors⁴ and parking garage luminaires (see Figure 4.1).

OLED products have been introduced by a couple of manufacturers.⁵ Customers have appreciated the aesthetics of these products, especially in terms of shape, product sleekness, uniformity of light distribution, and smoothness of dimming performance. However, product efficacy is lower than LED products,⁶ and cost is an overwhelming barrier to widespread adoption of OLEDs for illumination applications (DOE, 2015).

The combination of LED and OLED technology into one luminaire leverages benefits from both of the technologies. An example of this (Figure 4.2) is a luminaire with both a direct and an indirect light distribution, with LEDs emitting light upward toward the ceiling and OLEDs emitting the light that is seen from below.

Color quality has increased with products offered in a wider range of correlated color temperatures (CCTs), and high color rendering index (CRI) R_a values. For example, products that are used for accent lighting in museums offer

⁴ See, for example, Lumination™ LED Luminaire—EP Series website at <http://www.gelighting.com/LightingWeb/na/solutions/indoor-lighting/suspended/lumination-ep-series.jsp>.

⁵ AcuityBrands, “Current OLED Light Products,” <http://www.acuitybrands.com/oled/products>, accessed March 7, 2017.

⁶ AcuityBrands, “Why OLED,” <http://www.acuitybrands.com/oled/why-oled>, accessed March 7, 2017.



FIGURE 4.2 Acuity Brands Duet SSL™ Technology luminaire. The luminaire combines an OLED that provides diffuse lighting combined with LED uplights that are the primary source of ambient light. SOURCE: Acuity Brands, “Inspiration Through Concepts: Coming Soon... Olessence™ by Peerless® Lighting—Introduced at LIGHTFAIR® International 2016,” <http://www.acuitybrands.com/oled/inspiration-through-concepts>, accessed August 9, 2016. Courtesy Acuity Brands.

quality colors without harmful infrared and ultraviolet light that can degrade the artwork.⁷

Lighting Control Trends

In residential lighting, LED lamps for wirelessly connected homes are becoming common, and there are many brands that can be purchased in home improvement stores (Colon and Torres, 2017). These products are intended to replace the standard incandescent or compact fluorescent light (CFL) lamps in homes and be controlled by smartphones or tablets. Control interfaces allow users to switch, dim, and change the color of the lighting. Some of these systems can be as simple as a lamp or group of lamps together that are paired with a remote control device.⁸ Others include a bridge that is also connected to the internet via the local Wi-Fi network. These bigger systems can control lighting in an entire house and include other devices, such as window shades and thermostats. The use of a bridge enables connection to a smartphone or tablet, which gives the user remote control capabilities when away from home. Different manufacturers use different communication protocols, such

⁷ National Gallery of Art, “Effects of Light Exposure,” <http://www.nga.gov/content/ngaweb/conservation/preventive/preventive-light-exposure.html>, accessed March 7, 2017.

⁸ Pairing is done either in the factory or during the installation.

FIGURE 4.3 Audi's Matrix laser headlights. SOURCE: L. Ulrich, 2015, Audi pixelated laser headlights light the road and paint it too, *IEEE Spectrum*, May 6, <http://spectrum.ieee.org/cars-that-think/transportation/advanced-cars/audi-headlights-the-road-with-pixelated-laser-headlights>.

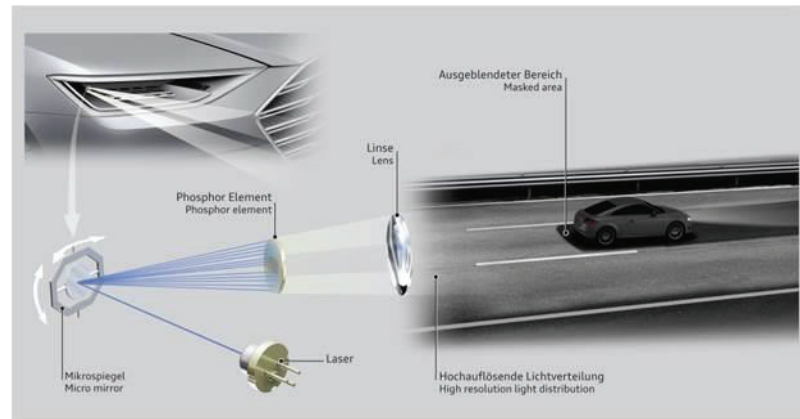

as ZigBee,⁹ Wi-Fi,¹⁰ Bluetooth,¹¹ or proprietary protocols. The lighting industry has formed a consortium called the Connected Lighting Alliance,¹² which has endorsed the use of ZigBee 3.0 as the preferred open protocol for manufacturers to adopt. One of the main concerns for smart home systems with a hub is security. Hackers can break into these systems and gain access to personal information (Moore, 2016; Halper, 2016; Grau, 2015).

The use of controls in municipal applications (e.g., roadways) is discussed in the section "Retrofit Applications." The use of controls in industrial applications is discussed in the section "Product Design and Specification."

Automotive Applications

Although automotive lighting applications do not directly contribute to the Department of Energy's (DOE's) energy savings goals, they do provide market opportunities for new technologies at early stages. With time, performance improvements and cost reductions allow these devices to be used in general illumination applications. During the past two decades, LEDs have found applications in cars and other vehicles, both inside and outside. According to Strategies Unlimited, LEDs will enjoy the most growth in general lighting and in automotive applications during the next several years (Pruitt, 2015).

New applications include headlamps using LEDs and laser diodes, car-to-car communication using visual light communication (VLC), and the use of OLEDs for aesthetics. Automakers have demonstrated the use of semiconductor lasers in cars (Figure 4.3). These laser lighting systems use phosphor conversion of the blue laser light to create white

light. Micromirrors break the beam into pixels that shine on the roadway and on road signs. This headlamp system can direct the light away from oncoming traffic to prevent blinding the drivers of other vehicles.

In cars, VLC will likely use low data rates and inexpensive sensors to make the overall cost affordable (Lewin, 2014). Some applications for OLEDs in cars include dashboard displays, heads up displays, inside digital rear-view mirrors, interior lights, such as dome lights, and external lights, such as tail lights and turn signals.¹³

Retrofit Applications

The majority of existing lighting applications use legacy products. Replacement of these products has slowly begun. The most common retrofit is a lamp replacement, with mixed results.¹⁴ For example, in commercial applications, linear fluorescent lamps can be replaced with tubular LED (TLED) lamps. The performance of TLEDs differs greatly from fluorescent tubes, including the spatial distribution of emitted light (Gavin, 2014). For example, GE Lighting's TLED has a beam angle of 130 degrees instead of the 360 degrees of a fluorescent tube (GE Lighting, 2014). Reflectors in fluorescent fixtures are designed specifically for 360 degree emission. The function of the reflectors is considered when the locations of the fixtures are specified, to achieve a reasonably uniform distribution of light. The use of TLEDs with different distributions in existing fixture installations can result in overly bright and dark patches throughout spaces. Other concerns include the use of ballasts (and associated safety concerns about disconnecting them), power quality, dimmability, and increased weight on the sockets (*LEDs*

⁹ See, for example, the ZigBee Alliance website at <http://www.zigbee.org>.

¹⁰ See, for example, the Wi-Fi Alliance website at <http://www.wi-fi.org>.

¹¹ See, for example, the Bluetooth Alliance website at <http://www.bluetooth.com>.

¹² See, for example, the Connected Lighting Alliance website at <http://www.theconnectedlightingalliance.org>.

¹³ See OLED-Info, "Automotive OLEDs: An Introduction and Market Status," <http://www.oled-info.com/oled-cars>, accessed October 27, 2016.

¹⁴ J. Benya, "The TLED, an LED Replacement Lamp for the Fluorescent Tube," *Focus on Energy*, http://www.uslamp.com/TLED_Article_Jim_Benya.pdf, accessed October 27, 2016.

Magazine, 2014). The Underwriters Laboratory (UL) classifies TLEDs into three types: Type A TLEDs operate on existing fluorescent ballasts, so they serve as direct replacements for fluorescent tubes. Type B TLEDs connect directly to a building's line power and require the removal of the ballast from the circuit. Type C TLEDs require a separate driver, requiring the existing ballast to be replaced by a driver in the luminaire. Type B TLEDs raise a specific concern, which is not shared by all in the lighting industry, because the lamp sockets for linear fluorescent lamps are typically not rated for line power connections, leading to potentially unsafe installations, unless lamp sockets are replaced.¹⁵ In addition, some Type B TLEDs have the same pin configurations as the fluorescent tubes they replace. This leads to concerns that, in the future, a TLED could be replaced with a fluorescent tube, which requires a ballast that would not otherwise be present. A final consideration for all types of TLEDs is that the energy and financial savings from these retrofits are very small because of the high efficacy and inexpensive prices of fluorescent lamps they are replacing.

In exterior lighting, early street lighting replacements have experienced some negative public feedback, especially due to increased glare and blue light appearance (Sciigliano, 2013; Andrews, 2015). Dark Sky advocates also are encouraging either minimal or no short-wavelength (blue) light in exterior lighting to minimize skyglow (IDA, 2010). Exterior applications have greatly improved with more attention on warmer CCTs, reduced glare, and increased use of dimming controls to adjust light intensity during periods of low activity (GE Lighting, 2015; Hill, 2016). Municipalities are limiting CCT and allowing adaptive lighting controls to dim the LED street lighting late at night.¹⁶ The American Medical Association (AMA, 2016) has written a position statement—discussed below in the section “Lighting for Health”—on the effects of street lighting on the circadian rhythms of people, recommending that street lights have CCTs of 3,000 K or less.

In residential and commercial applications, smooth, flicker-free dimming is typically expected. This can be very difficult to achieve when LED lamps are operated with existing incandescent dimmers. Many lamps are either non-dimmable or need to operate on a dimmer designed specifically for LED loads. LED loads draw low power, and incandescent dimmers typically have a minimum load rating of 20–40 W, which the LED load often does not satisfy. In addition, so called “smart dimmers” (which continue to operate when the

lamp light output is off) require the lamps to allow current to flow through, to allow the dimmer to function, without turning on the LEDs. Both of these situations are addressed by the National Electrical Manufacturers Association (NEMA) SSL 7A standard (NEMA, 2016), as discussed in the section, “Industry Standards,” in Chapter 2. The installation of replacement luminaires in existing ceilings has challenges beyond legacy dimming systems, including limited ceiling access and existing electrical distribution systems not being designed for nonlinear loads.¹⁷

CURRENT CHALLENGES

Lighting designers still struggle with specifying SSL technology, especially as the technology continues to evolve. These issues were highlighted in a DOE Lighting Designer Roundtable report (DOE, 2016a):

- There is a need for a method to compare products easily, especially when there is a specification requirement to name a primary product plus two alternative products from different manufacturers.
- There is a lack of transparency with regard to warranty coverage as market and sourcing remains unsettled. Some users have suggested the LED Lighting Facts label include such warranty information.
- It is difficult to evaluate products from data. Designers want to physically see each product.
- Information on drivers is needed, since driver failures are a problem.
- There is a lack of information and protocols on compatibility with controls.
- Products change so rapidly (during the design process and construction process) that catalog numbers are no longer current or the products are discontinued.

The lighting specifiers also discussed product data they need in order to specify projects, which is sometimes difficult to obtain. Data includes specifications for drivers and controls, color properties, information about optics, and many general information items, including flicker rate, code compliance, chip/module type, and manufacturer information.

Users are comparing SSL retrofit products with legacy lamps and luminaires and expecting equal or better performance. For instance, users expect smooth, flicker-free dimming and, in some applications, a warmer color appearance as the lamps dim.¹⁸ There is also confusion over luminaire and lamp compatibility with control systems (DOE, 2016a). Designers still have little knowledge of and information about power supplies or drivers. They rely on the luminaire manufacturers for control system compatibility information.

¹⁵ Several manufacturers (e.g., Maxlite, Premier Lighting, LaMar Lighting) market Type B TLEDs listed to UL 1598C. For a contrary opinion, see, for example, GE Lighting, 2014, “Considering LED Tubes,” 16339 (Rev 07/28/14), http://www.gelighting.com/LightingWeb/na/images/16339-GE-LED-Tube-Lighting-Refit-Solutions-Whitepaper_tcm201-69385.pdf. There is no consensus within NEMA on this issue, and therefore no white paper exists.

¹⁶ See Smalley (2013), Los Angeles Bureau of Street Lighting (2014), and San Francisco Water Power Sewer, “LED Street Light Wireless Control Pilot Project,” <http://sfwater.org/index.aspx?page=746>, accessed August 9, 2016.

¹⁷ National Electric Code (NEC) 310.15(B)(5)(c) and NEC 210.4 (A) Informational Note No. 1.

¹⁸ Ann Kale, Ann Kale Associates, Inc., presentation to the committee on February 23, 2016.

Frustration over the lack of driver standards and choices is evident (DOE, 2016a). As discussed in Chapter 2, the lighting industry has made some progress in these areas recently, and this issue is also addressed in the section “Retrofit Applications.”

SSL products can fall short of promises made, which is a further source of dissatisfaction of some users. As some of the earliest commercialized products age, evidence of long-term effects, such as color shifts, power supply failure, and shorter-than-expected product lifetimes (Poplawski, 2013; Royer, 2013; Miller, 2013) is starting to appear. SSL products sold today have most certainly improved over those that were commercialized first, but the industry nevertheless has to contend with some of these negative impressions.

LED System Lifetime

LED lighting product life is one of the least understood factors of system performance. As a result, any lifetime claim for a complete LED lighting system, such as a lamp or luminaire, is essentially a guess. According to current industry standards, LED system lifetime is defined based on LED package lifetime (L70) in hours. The LED used in the product is tested according to IES LM-80, and the operation time to reach the 70 percent of initial luminous flux is projected according to IES TM-21. However, there are more components in an LED product than just the LED package, and currently there are no agreed-upon tests for larger systems such as light engines or luminaires. The failure of any component will result in product (i.e., luminaire) failure (DOE, 2013; NGLIA, 2014), the import being that components have an influence on the lifetime of the luminaire.

In general, LED lighting system failure can be parametric or catastrophic. When an LED system functions in the intended manner but outside the normal operating limits, failure is referred to as parametric. Lumen depreciation and chromaticity shifts are examples of parametric failure. When an LED system fails to produce light, this is referred to as catastrophic failure. LED failures due to closed or open circuits that cause complete loss of light are examples of catastrophic failure. In an LED system with many components, thermal expansion mismatch produces mechanical stresses that can cause material fatigue and lead to failure.

In LED applications, typically a lighting system is turned on and off. Research studies have shown that on-off cycling of an LED system can cause increased catastrophic failure compared to continuous-on only operation (Narendran and Liu, 2015). Therefore, LED system life testing should include on-off cycling. A recent life-test study investigated the impact of environment temperature and system use (on-off) pattern on LED product lifetime.¹⁹ Contrary to the

common belief that the operating life of an LED product is unaffected by switching, results show that life is impacted by the application environment and on-off switching pattern.²⁰ The International Electrotechnical Commission (IEC) is currently developing an SSL reliability standard.²¹

FINDING: The lifetimes of LED lamps and luminaires are estimated to be the time at which the luminous flux of the lighting product is expected to be 70 percent of initial luminous flux, based on continuous operation tests of the LED packages. Since LED systems are switched on and off during operation and are composed of many components, a proper LED system life test method should test the entire system with on-off cycling. Furthermore, both lumen maintenance and catastrophic failures should be considered when reporting product lifetime.

RECOMMENDATION 4-1: The Department of Energy should support light-emitting diode system lifetime research and encourage the Illuminating Engineering Society to develop a standardized system lifetime test method.

EMERGING SSL APPLICATIONS

SSL technologies offer advantages that legacy technologies lack, such as small size, spectral flexibility, increased controllability, and high product efficacy. SSL also provides opportunities to develop new feature-rich products that provide additional benefits to users, with functions beyond illumination. Products designers, as well as lighting designers, are exploring new ways of using SSL products in innovative, dynamic lighting designs (DOE, 2016a). Dynamic lighting includes features such as changeable spatial distributions of emitted light, spectral tuning, and schedule programming, in addition to intensity variation.

However, light can be used for other purposes, some of which are becoming more widespread. Strictly speaking, some of these applications, such as agricultural lighting, are unlikely to reduce energy consumption and have the potential to do the opposite. However, if growth of these applications is inevitable, DOE may wish to consider ways of maximizing efficiency. Some of these applications, such as visible light communication, have the potential to increase the functionality of lighting that is also used for illumination. Growth of these applications may present new business opportunities for lighting manufacturers. In the following sections, the committee reviews both technology-enabled illumination applications as well as several non-illumination applications and explains the value propositions for each. Where applicable, the status and appropriateness of energy efficiency standards tailored to these applications is discussed.

¹⁹ See Narendran et al. (2016) and Lighting Research Center, “Developing a Predictive Life Test for LED Systems,” <http://www.lrc.rpi.edu/programs/solidstate/LEDSystemLife.asp>, accessed March 7, 2017.

²⁰ Ibid.

²¹ IEC 62861, private communication with Karen Willis, Senior Lighting Program Manager at NEMA, June 23, 2016.



FIGURE 4.4 Holophane Tunnel Lighting Pro Beam Fixture. SOURCE: Acuity Brands Lighting, Inc., http://www.signalcontrol.com/products/holophane/Holophane_Tunnel_Predator.pdf, accessed August 9, 2016.

Spatial Distribution and Form Factors

Changeable spatial distributions of light can be achieved by single luminaires that adjust the pattern of emitted light through a control system. For instance, instead of having separate accent lights and wall washers, one luminaire could accomplish both of these lighting effects. A hand-held control device may have a photo of the interior space; a user just has to touch the area that requires lighting, and the luminaire responds. An example of this is OSRAM's OmniPoint luminaire (OSRAM, 2015). In exterior lighting, a pole-mounted luminaire could illuminate the street with an asymmetric "pro-beam" distribution (Figure 4.4) where light only is distributed in the direction of traffic (extension of headlamps), similar to what is done in some tunnel lighting, and provide separate sidewalk illumination when a pedestrian is present.

OLEDs have the potential to facilitate unique applications of light. In order for OLED products to be widely adopted, several barriers, such as cost and efficacy, need to be overcome.²² In the future, OLED products may be transparent, be available in dynamic shapes, be available in larger size panels, and feature spectral tuning.²³ In these ways, OLEDs have the potential to offer aesthetic possibilities that cannot be readily achieved with other technologies. Further developments in OLED luminaire technologies are uncertain, since

²² Office of Energy Efficiency and Renewable Energy, "SSL R&D Challenges," <http://energy.gov/eere/rd-challenges>, accessed October 27, 2016.

²³ Sebastian Suh, "LG Display," presentation to the committee on February 24, 2016.

OLEDs are being developed by the display industry and currently have very little presence in the lighting industry.²⁴

Since the goal of the DOE SSL program is to reduce the energy consumed by lighting, the focus has primarily been on existing uses of light. These are predominantly illumination applications in which the intended function of the light is to enable people to visually perceive illuminated objects.

Lighting for Health

DOE has identified addressing physiological responses to light as one of the key issues and challenges for LEDs. In the core technology research and development (R&D), DOE (2016b) has identified blue light hazard, health, and productivity for humans as the particular challenges. The AMA (2016) outlines several health concerns associated with excessive short-wavelength (blue) light, including disability glare and possible retinal damage. In addition, they are concerned with environmental disruption for many nocturnal species, as well as human circadian rhythms disruption, by blue light at night. Circadian disruption from outdoor street lighting, indoor room lighting, and electronic devices (e.g., computer monitors and mobile devices such as cell phones) during the evening has been associated with sleep disruption, obesity, impaired daytime functions, and increased cancer risks. The AMA strongly recommends warm white light (3,000 K or less) for nighttime lighting, shielded lights to

²⁴ Ibid.

prevent light trespass into homes, and dimming or turning off outdoor lighting when not needed.

The spectral power distribution of illumination can be adjusted, to minimize the potential negative effects of light, by tuning the spectral power distribution of light emitted by luminaires. Spectral tuning can be implemented as white tuning (blending warm white and cool white LEDs in different proportions) or as a variation on red-green-blue (RGB) color mixing. There is some research on the effects of light source spectrum on circadian rhythms²⁵ and ecological consequences²⁶ of certain wavelengths during periods of darkness. The effects of exposure duration, wavelength, and intensity are still being investigated, while broad assumptions about these effects are already being addressed by voluntary standards (IES, 2008; DIN, 2015).²⁷ Given the current lack of consensus, further research is needed in order to provide product developers, lighting designers, and consumers with guidelines (Brainard, 2001, 2012; Figueiro et al., 2004, 2008, 2013, 2014, 2016; Figueiro and Rea, 2012; Figueiro, 2015, 2016; Rea et al., 2005; Rea and Freyssinier, 2013; Sahin and Figueiro, 2013; Thapan et al., 2001; Wood et al., 2013; Young et al., 2015).

An experiment is under way to regulate the circadian rhythms on astronauts on the International Space Station (ISS) with light. Since the cycle of sunlight and darkness occurs every hour on the ISS, it is difficult to use daylight for regulation of melatonin. A team of researchers (Brainard et al., 2012) have developed a dynamic spectrum lighting system that changes the color of light to help the astronauts fall sleep in their sleeping compartments. Instead of using medications to go to sleep, light that is void of short wavelengths is used.

FINDING: Although there is clear evidence that circadian rhythms are impacted by short-wavelength (blue) light, the consequences of these impacts are not fully understood. DOE has an R&D program that prioritizes investigations of physiological impacts of light.

Horticultural Lighting

Photosynthesis, the process by which plants convert carbon dioxide and water into carbohydrates (energy) and oxygen, requires chlorophyll pigments to absorb light. While this light traditionally comes from the Sun, there are numerous reasons to consider the use of electric lighting for horticulture. Food is transported an average of 4,200 miles throughout its life cycle, accounting for 11 percent of its

carbon footprint (Weber and Matthews, 2008). Transportation from the food producer to the retailer is responsible for only 4 percent of the carbon emissions, however. Increased globalization of food production also makes countries vulnerable to food insecurity as a result of political conflict and natural disasters in other parts of the world (Weber and Matthews, 2008). The ability to grow crops outside of their natural climate zones and in spaces smaller than conventional farmland can reduce the energy consumed by transportation and reduce the risk of food shortages due to the global events.

Many crops appear green in color because they reflect more of the middle wavelengths of the visible spectrum (green light) and absorb more of the longer (red) and shorter (blue) wavelengths of light. Light throughout the visible spectrum can induce photosynthesis, but research has shown that crop yield is most heavily impacted by spectral power of relatively long wavelengths (red) and, to a lesser extent, spectral power of relatively short wavelengths (blue) (McCree, 1972).

Electric lighting technologies, particularly fluorescent and metal halide lamps, have successfully been used to grow plants indoors for decades (Helson, 1965; Duke et al., 1975). More recently, research has explored the use of the LEDs for horticultural lighting. The study of one plant species showed that a combination of red and blue LEDs resulted in greater plant mass, leaf area, and chlorophyll content than a broadband fluorescent lamp or illumination by either single color (Kim et al., 2004).

Luminous efficacy, with the unit of lumens per watt, has meaning only in the context of human vision. The unit of luminous flux is the lumen, which is a function of the radiant flux of a light source, its spectral power distribution, and the visual system's sensitivity to the different wavelengths in the visible spectrum. As such, it is not applicable to any other animal species (e.g., livestock) or to plant species. The need for different standards for the plants and livestock is not well understood by some in the building and lighting industries—Washington State has adopted a minimum luminous efficacy requirement for lighting used for plant growth.²⁸ Unfortunately, this has the potential to unnecessarily increase energy use, with no benefit to the plants. There was also a proposal to the International Energy Conservation Code (IECC) 2018 to adopt a minimum luminous efficacy standard for lighting products used in plant growth. Fortunately, the code panel did not accept this proposal and a new, better-informed proposal will be developed. Lighting efficacy standards for such applications remain a work-in-progress.

The photosynthetic absorption spectrum of a typical plant is shown in Figure 4.5. The sensitivity of the human visual

²⁵ G.C. Brainard, and J.P. Hanifin, Thomas Jefferson University Light Research Program, "Ecology, Physiology, Human Health and Light," presentation to the committee on February 24, 2016.

²⁶ Travis Longcore, "Ecology, Physiology, and Solid State Lighting," presentation to the committee on February 24, 2016.

²⁷ International Well Building Institute, "WELL Building Standard®," <https://www.wellcertified.com>, accessed October 28, 2016.

²⁸ Private communication with Duane Jonlin, Energy Code and Energy Conservation Advisor to the City of Seattle, May 10, 2016. The 2015 WA State Code requires a luminous efficacy of at least 90 lm/W for lighting for plant growth or maintenance. Mr. Jonlin was able to change the requirement for the City of Seattle to a minimum requirement for the photosynthetic photon flux per watt of the light source, which makes more sense.

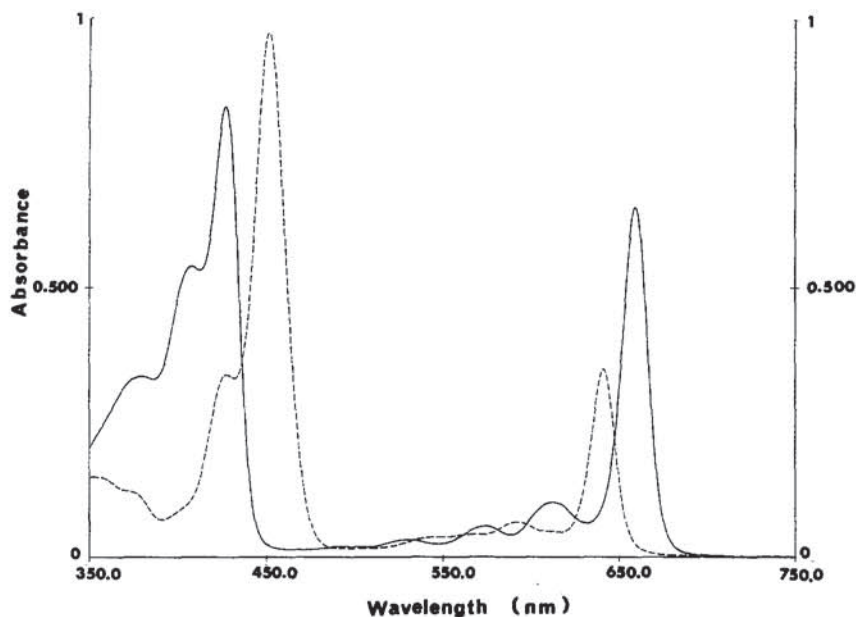

FIGURE 4.5 The photosynthetic absorption spectrum of a typical plant is shown. There is very little absorption in the middle (green) wavelengths where the human visual system is the most sensitive (555 nm). SOURCE: H. Lichtenhaler, 1987, Chlorophylls and carotenoids: Pigments of photosynthetic biomembranes, *Methods in Enzymology* 148:350-382. Courtesy of Professor Dr. Hartmut Lichtenhaler.

system, not shown, peaks at 555 nm. At this wavelength, plants have very little photosynthetic absorption. Optimizing for luminous efficacy clearly makes little sense when designing lighting products for plant growth.

Some plants thrive when lighted with blue and red grow lamps, such as shown in Figure 4.6.

The quality of light for plants is an active field of research among plant scientists. In addition to photosynthesis, researchers are interested in photomorphogenesis, which is a study of light-mediated development in plants, such as seed-formation, seedling development, and blooming. As is the case for lighting spaces used by people, it is important to strike the right balance between energy efficiency of the lighting system and the quality of light for the needs of plants. It is too early to develop standards for plant growth lighting in terms of some form of efficacy. Furthermore, such efficacy will most likely be species-dependent.

Livestock Lighting

Lighting also has an impact on the development of animals used for food. For example, days with longer exposure periods to light (photoperiods) increase the amount of milk produced by dairy cows (Peters et al., 1978; Dahl et al., 2000). Cattle, sheep, and deer also show increased growth with longer photoperiods (Forbes, 1982). In many instances, longer photoperiods induce more food consumption, which accounts for the growth (Forbes, 1982). Some research has shown that, when the amount of food consumption was controlled for, animals with longer photoperiods were larger, but not heavier, than those with shorter photoperiods (Peters et al., 1978). However, other research has found that increased

photoperiods increased the weight of cattle without increasing their food consumption (Peters et al., 1978).

Increased photoperiods have not been universally found to be beneficial. For instance, the sudden onset of excessively long photoperiods (23 hours per day) has been linked to increased incidences of growth abnormalities and mortality in broiler chickens (Classen and Riddell, 1989).

The effect of light intensity on animal growth has not been thoroughly studied. Broiler chickens exposed to higher intensities of light (150 lux [lx]) had lower body fat and higher body protein than those exposed to lower intensities (5 lx) (Charles et al., 1992). Illuminances greater than 5 lx during rearing do not appear to impact the rate of sexual maturation of broiler chickens raised for breeding (Lewis et al., 2008). Illuminance also does not have an impact on egg production, provided it is at least 10 lx (Lewis et al., 2008).

Similarly, limited research has investigated the impact of light color on animal behavior and growth. One study (Prayitno et al., 1997a) has found that chickens raised under white light demonstrated more walking than those reared under red, blue, or green light. Those raised under red light displayed more pecking at the floor, wing-stretching, and aggression than those illuminated by the other colors. However, growth and food consumption was not impacted by light color. Another study (Prayitno et al., 1997b) exposed adult chickens to white, red, blue, and green light in alternation. No significant difference in behavior or energy expenditure was found as a result of illumination by the different colors.

While most of the research on the impact of light on livestock focused on food production, animal preferences can inform the design of lighting systems that maximize animal welfare. A study of the illuminance preferences of pigs found



FIGURE 4.6 Some plants grow well under lighting that would not appeal to humans and has very poor luminous efficacy as expressed in lumens per watt. SOURCE: Neil Mattson, Cornell University, “LED Lighting for Plant Applications,” presentation to the committee, February 24, 2016.

that they significantly preferred the lowest illuminance available to them (2.4 lx) to the other available illuminances (4 lx, 40 lx, and 400 lx) (Taylor et al., 2006). When cattle were taught to control electric lighting in their enclosure, they chose to be illuminated about half (54 percent) of the time (Phillips and Arab, 1998). In these cases, research on animal behavior suggests that less lighting consumption can be beneficial to animal health and have co-benefits for reduced energy consumption for illumination. DOE’s 2016 R&D Plan (DOE, 2016b) discusses livestock production briefly, and the impacts of lighting on livestock production are included in its prioritized investigation of physiological impacts of lighting. DOE speculates that LED lighting could have benefits for animal behavior and well-being because of the ability to tune

the color of the light, in addition to reducing energy costs, compared to incandescent lighting.

FINDING: Some state and local building energy codes are starting to consider efficacy requirements for lighting in applications other than illumination, such as plant growth. DOE has an R&D program that prioritizes investigations of physiological impacts of light (DOE, 2016b), including plant and livestock responses to light.

RECOMMENDATION 4-2: The Department of Energy should consider initiating a broad stakeholder project to develop appropriate energy efficiency metrics for the most important emerging lighting applications, including horti-

culture and livestock, that are not for illumination of spaces used by people.

Smart Lighting

Smart lighting can deliver traditional illumination and provide new functionality. The Internet of Things (IoT), connected lighting, and smart lighting are terms commonly used in the lighting industry today. In the initial period of SSL advancement, LED light sources succeeded in saving energy in most lighting applications. Now, with better lighting controls and connectivity to a network, LED lighting is evolving toward the IoT to provide greater value to end users (O'Malley, 2015; Harbers and Manney, 2014).

To address security concerns and bandwidth limitations of communications systems, communication using visible light is being considered and studied. This is called Visual Light Communication (VLC) and has also been given the name Li-Fi (Light Fidelity) by the IEEE standardization committee,²⁹ whose scope covers this technology.

Li-Fi systems are networked two-way data communication systems that use visible light by switching the current to the LEDs on and off at high temporal frequencies, beyond the flicker fusion frequency of the human visual system. Li-Fi has potential to be very high speed, perhaps as much as 100 times faster than Wi-Fi, with demonstrations claiming to have achieved data transmission rates of from 500 megabits per second (Grobe et al., 2013) to 9 gigabits per second (Gbps) (Chi et al., 2015) and on up to 200 Gbps (*BBC News*, 2015). Because communication uses visible light, it is limited to a line-of-sight, meaning that it cannot be used to communicate through walls or other such opaque obstacles. This limits the communication range compared to radio transmission, but has the benefit of not being detectable outside enclosed walls and is not easily subject to eavesdropping.

In addition to building systems communication,³⁰ VLC also can be used to communicate with occupants via smart devices. Today several companies are developing VLC systems for shoppers at stores.³¹ In these systems, a shopper's smartphone works with the LEDs in the light fixtures in the store. These sensors can detect the shopper's location within the store, identify the displayed items being viewed by the shopper, and transmit promotional materials to the shopper's smartphone with the hope of aiding businesses to increase sales.³²

Commercial lighting IoT is promising to transform the way spaces are illuminated with some systems focusing on total energy reduction through a variety of strategies (such

as occupancy sensing, daylight harvesting, dimming, etc.). Light fixtures, with sensors and a network connection, can sense the environment and send commands to the LEDs to change lighting characteristics to cater to the needs of the application. Sensors can detect not only that a room is occupied but also by how many people are in the room, so that the ventilation system can be adjusted accordingly, for instance. In outdoor applications, "smart cities" is a popular term these days.³³ In this application, outdoor light poles and street and area light fixtures are outfitted with sensors and cameras that can be networked to make cities more energy efficient and safe (Murthy et al., 2015) by detecting crimes and reporting them automatically to the police. Likewise, for indoor applications, several companies have launched add-on systems to help existing building management systems conserve energy and service failed hardware. Despite the enthusiasm in the industry and potential benefits, IoT lighting has many challenges to overcome before gaining widespread use. These include privacy and security concerns, standards and interoperability of lighting products, and regulations. The concern about regulations is also discussed in Chapter 2.

Lighting companies have begun collaborating with information technology (IT) companies, including GE, Apple, and, in a joint venture, Acuity and Qualcomm.³⁴ Since the United States is strong in IT, this is a potential area of lighting in which U.S. industry can excel.

FINDING: The number of applications in which SSL is being used has greatly increased since the National Research Council's 2013 report *Assessment of Advanced Solid-State Lighting* was released. These new applications that go beyond illumination are attracting a diverse set of companies from adjacent markets.

IMPEDIMENTS TO INNOVATION

Some impediments to innovation are simply the result of the relative immaturity of the SSL. For instance, the commercialization of OLED lighting products is limited by a lack of basic measurement methods. There are no industry standards for the measurement of luminous flux, luminous efficacy, chromaticity, spectral power distribution, color rendering, or lumen maintenance of OLED luminaires. This is obviously problematic for the specification of OLEDs, but it also makes it difficult to track technological developments of OLEDs and compare their performance to other lighting technologies. Consensus standards do not exist for the measurement of basic photometric and colorimetric quantities of

²⁹ IEEE 802.15.7r1.

³⁰ See, for example, Lux, 2016, "World's First Li-Fi Office Opens in Paris," June 27, <http://luxreview.com/article/2016/06/world-s-first-li-fi-office-to-open-in-paris?cmpid=LUXproducts06302016>.

³¹ See, for example, LaMonica (2014).

³² *Wikipedia, The Free Encyclopedia*, "Li-Fi," last update March 7, 2017, <https://en.wikipedia.org/wiki/Li-Fi>.

³³ Silver Spring Networks, "Silver Spring Networks for Smart City Street Lighting," <http://www.silverspringnet.com/article/silver-spring-networks-expands-smart-city-infrastructure-platform-through-new-collaboration-with-street-lighting-pioneer-selc/>.

³⁴ Marc Saes, Acuity Brands, and Aleksandar Jovicic, Qualcomm Inc., "LED Lighting as a Platform for Indoor Positioning for Mobile Devices," presentation to the committee on February 24, 2016.

OLED lighting products. Such standards do exist for LEDs, including LM-80-15: IES Approved Method: Measuring Luminous Flux and Color Maintenance of LED Packages, Arrays and Modules; as well as TM-21-11: Projecting Long Term Lumen Maintenance of LED Light Sources. These apply to LED sources, only.

Though problematic, impediments like these are not insurmountable. Test methods can be developed if there is sufficient demand and commitment. Other challenges are more insidious, however. Current lighting design practices may be inhibiting the industry's ability to develop truly innovative applications with SSL.

Lighting Metrics

Many of the methods, measurements, and norms used in lighting design arose from the characteristics and limitations of old lighting technologies. For instance, the most commonly used measure of chromaticity for white light sources is CCT, which indicates the temperature of a blackbody radiator that is most similar in chromaticity to the light being described. The spectral power distributions (SPDs) of incandescent lamps approximate the spectra from blackbody radiators, but more modern lighting technologies are vastly spectrally different. There is no scientific evidence to support the premise that the chromaticities produced by incandescent sources are optimal for illumination. In fact, the limited research on this topic suggests that they are not (Rea and Freyssinier, 2013; Ohno and Fein, 2014). Nonetheless, product performance standards for chromaticity pressure manufactures to develop products with chromaticities most like incandescent technologies,³⁵ although changes to the SSL chromaticity standard are currently being considered.³⁶ Similarly, current color rendering metrics, including the CRI (CIE, 1995) and the new method described in IES TM-30 (IES, 2015), are rooted in the assumption that the appearances of colored objects are ideal when illuminated by an incandescent-like SPD for many chromaticities. Light sources that render color appearance differently are penalized, even though evidence suggests that these blackbody spectra do not lead to the most natural or attractive appearance of colored objects (Jost-Boissard et al., 2009; Ohno et al., 2015). Although color quality is widely believed to be an important aspect of consumer acceptance, the metrics used are quite rudimentary and based on the presumption that the first widely commercialized lighting technology was perfect.

Product Design and Specification

Throughout the lighting design process, the intrinsic traits of incumbent technologies still dictate the shape and

size of lighting products, patterns of emitted light, and ways in which lighting products are integrated into buildings. Even the role of lighting designers in design teams and the stage at which they are engaged with design projects are consequences of traditions that were shaped by the technologies available long ago. For instance, legacy products such as fluorescent luminaires and dimming ballasts come in standard options and are easy to specify and commission. Designers can select the same dimming ballast for many fluorescent luminaires. With SSL, each luminaire must be tested with a specific driver to obtain a UL certification, limiting the choices of equipment. As discussed in Chapter 2, UL has started a Class P LED driver program, which will harmonize the handling of these products with the way that the industry handles fluorescent lamp ballasts. The program is just starting, so it is premature to comment on results. Another example is the incompatibility between various light engines, drivers, and control systems. The interface between the light engine and the LED driver needs to be understood by the designer because there are two categories of LED drivers: constant current output and constant voltage output. When the former is used, it is possible to add LED modules in series up to the total power rating of the driver. But if constant voltage output is employed in the driver, each module must be rated for that voltage, and additional loads are added in parallel to each other up to the power rating of the driver. The interface between the control system and the driver is equally important for the designer to understand and specify. Common control inputs to the driver include phase-cut dimming (NEMA, 2016), DALI (digital) control,³⁷ DMX control³⁸ (another form of digital control commonly used in theatrical lighting), and 0-10 V analog control.³⁹ As a result, designers must now act as control integrators in order to commission and troubleshoot problems in the field. Lighting control designs now need to include specifications of scenes, locations of automatic and dynamic controls, communication with fully networked devices, and the integration of Internet-connect and/or mobile apps (Weissman, 2014). This adds responsibilities that traditionally were not part of typical design scope and fees.⁴⁰

FINDING: The lighting industry has developed standards for control interfaces for LED drivers, and there are industry conventions for driver output ratings. In addition, UL, in collaboration with the lighting industry, has started its Class P driver program to allow designers more flexibility with driver choices.

³⁵ See, for example, ANSI (2015).

³⁶ Yoshi Ohno, NIST, "Color Metrics: Where Are We? Where Are We Going To?," presentation to the committee on February 24, 2016.

³⁷ See, for example, IEC (2014).

³⁸ Entertainment Services and Technology Association, DMX512-A standard.

³⁹ ANSI C137.1, in the process of being published.

⁴⁰ Chip Israel, "Lighting Design Alliance," presentation to the committee on February 23, 2016.

Similarly, approaches to the regulation of lighting products are outdated and, in some instances, hinder innovation. The development of connected (smart) lighting systems may provide additional functions that benefit users, such as lighting that aims to enhance the health of occupants. Some of these functions have little to do with providing illumination, but some of these operations have the potential to drastically reduce the energy consumed by lighting. These systems will consume a small amount of power, depending on the service that they provide, even when the lighting is off. At this time, regulators do not appear to understand these developments sufficiently.⁴¹ Instead, they are focusing on the luminous efficacy of the lighting system when illumination is provided and standby power consumption when the lighting is switched off. If the function of the standby mode is only to power the lighting equipment sufficiently to get input from sensors and other devices to turn lighting on when it's needed, limiting standby power consumption to a reasonable level makes sense. But when regulators extend the same approach to connected lighting products, there is a risk that restrictive regulations will impede innovation of these types of products. The IEC has started to study these needs in their standards and is separating the needs of standby power consumption and power consumed by secondary devices or functions.⁴²

FUTURE APPROACHES TO REDUCING ENERGY CONSUMPTION

Scientists and engineers, with support of DOE, have made remarkable progress increasing the luminous efficacy of lighting hardware (DOE, 2016b). DOE supports a goal of 200 lumens per watt (lm/W) luminaire efficacy by 2025, and this has been achieved in laboratory demonstrations. However, the energy consumed by lighting depends both on the luminous efficacy of the lighting technologies and the way in which those technologies are used to illuminate spaces. In illumination applications, the purpose of light is to enable users to see illuminated surfaces of objects, such as walls, floors, furniture, people, books, food, vehicles, etc. Only the light that reflects off illuminated objects and enters the eyes of viewers is useful—the rest of the light emitted is essentially wasted. From this perspective, the application efficacy of a lighting installation can be considered, both temporally and spatially. For example, if a room is lighted, but is unoccupied, energy is wasted, regardless of the luminous efficacy of the luminaires. Similarly, if a large space is illuminated, but occupants are not looking at all parts of it,

energy is being consumed needlessly to light portions of the space that are not viewed.

Some strategies to increase application efficacy are already widely used in lighting design. For example, lighting control systems that dim electric lights when daylight is present and systems that automatically turn lights off when spaces are unoccupied, are common in commercial spaces (Williams, 2012). However, current approaches to increasing application efficacy are predominantly the same as those used for legacy technologies. The unique characteristics of LEDs, including ease of digital control, optical properties, and spectral flexibility, enable more radical approaches to minimizing the energy consumed by lighting. For example, some manufacturers have capitalized on the small source size of the LED and developed optics with maximized efficiency to direct light only to the places where it is needed (Narendran et al., 2015).

Suggestions have been made that the computer graphics method of light-field mapping, in which the relationship between the lighting and the appearance of all illuminated objects within a viewer's field-of-view is determined in real time (Chen et al., 2002), could be leveraged in illumination applications. If an advanced lighting system were able to determine the visual field of all occupants in a building and tailor the lighting so that only the viewed surfaces were illuminated, application efficacy could be drastically improved (Tsao et al., 2014). In current lighting design practice, spaces are fairly uniformly lighted, a convention that is largely an artifact of the limitations of earlier technologies. Since occupants rarely view all portions of a space at any given time, much light is unseen and, therefore, wasted. Another proposed approach to increasing application efficacy suggests that the amount of light absorbed by illuminated surfaces can be reduced. Light absorption has traditionally been thought to be unavoidable in lighting design—the color and lightness of a surface determines the relative amount of light reflected to the observer and the amount absorbed and converted to heat. However, if each surface in a space were illuminated by light with a customized spectral power distribution that maximizes the amount of light reflected, application efficacy could be significantly increased (Durmus and Davis, 2015). Other approaches to increasing application efficacy could be simpler to implement. For instance, since the trade-off between luminous efficacy and color quality is known (Ohno, 2005), lighting systems could be developed that change these characteristics based on occupancy (Thompson, 2007). For instance, in spaces in which it is inappropriate to switch off lights in unoccupied zones (e.g., retail, hospitality, stairwells), high-efficacy, low-color-quality lighting could illuminate unoccupied areas. When occupancy is detected, the lighting could switch to higher-color-quality, lower-efficacy illumination. These instances show the opportunity to increase so-called application efficacy, above and beyond the improvement achieved from the luminaire (i.e., the product) by itself. These approaches to lighting are a significant

⁴¹ California Energy Commission, "Notice of Commission adoption hearing, availability of revised 15-day language, and opportunity for comment," January 7, 2016, http://docketpublic.energy.ca.gov/PublicDocuments/15-AAER-06/TN207218_20160107T132138_Notice_and_Revised_15Day_Language.pdf.

⁴² IEC 60598-1 8th Edition 2nd Amendment.

departure from current lighting design practice. Before they could realistically be implemented, a better understanding of the impact of lighting on the appearance of illuminated spaces is needed. Ideas for increasing application efficacy raise questions about the perception of lighting in peripheral vision, the detectability of temporal changes of lighting, and the impact of SPD on light absorption and color appearance. To minimize the energy consumed by lighting, lighting applications research is needed to complement advances in technology efficacy.

FINDING: The energy consumed by lighting is a function of both the luminous efficacy of lighting products and application efficacy of installations. DOE does set targets for light utilization for advanced luminaire systems in its R&D program, but its approach is still product focused.

RECOMMENDATION 4-3: The Department of Energy should develop strategies for supporting broader research that enables more efficient use of light in such a way that the *application efficacy* is maximized, with attention to both the lighting design process and the design of lighting products.

REFERENCES

- AMA (American Medical Association). 2016. *Report of the Council on Science and Public Health*. CSAPH Report 2-A-16. Chicago, Ill.
- Andrews, C. 2015. Are LED street lights a bright idea? *Houston Chronicle*. February 23. <http://www.houstonchronicle.com/local/gray-matters/article/Are-LED-street-lights-a-bright-idea-6837009.php>.
- ANSI (American National Standards Institute). 2015. American National Standard for Electric Lamps—Specifications for the Chromaticity of Solid State Lighting (SSL) Products. ANSI C78.377-2015. Rosslyn, Va.: National Electrical Manufacturers Association.
- BBC News. 2015. Li-Fi 100 times faster than Wi-Fi. November 27. <http://www.bbc.com/news/technology-34942685>.
- Brainard, G.C., J.P. Hanifin, J.M. Greeson, B. Byrne, G. Glickman, E. Gerner, and M.D. Rollag. 2001. Action spectrum for melatonin regulation in humans: Evidence for a novel circadian photoreceptor. *Journal of Neuroscience* 21:6405-6412.
- Brainard, G.C., W. Coyle, M. Ayers, J. Kemp, B. Warfield, J.C. Maida, C. Bowen, C. Bernecker, S.W. Lockley, and J.P. Hanifin. 2012. Solid-state lighting for the International Space Station: Tests of visual performance and melatonin regulation. *Acta Astronautica* 92(1):21-28.
- Charles, R.G., F.E. Robinson, R.T. Hardin, M.W. Yu, J. Feddes, and H.L. Classen, 1992. Growth, body composition, and plasma androgen concentration of male broiler chickens subjected to different regimens of photoperiod and light intensity *Poultry Science* 71(10):1595-1605.
- Chen, W.C., J.Y. Bouguet, M.H. Chu, and R. Grzeszczuk. 2002. Light field mapping: Efficient representation and hardware rendering of surface light fields. *ACM Transactions on Graphics (TOG)* 21(3):447-456.
- Chi, Y., D. Hsieh, C. Tsai, H. Chen, H. Kuo, and G. Lin. 2015. 450-nm GaN laser diode enables high-speed visible light communication with 9-Gbps QAM-OFDM. *Optics Express* 23:13051-13059.
- CIE (Commission Internationale de l'Éclairage). 1995. *Method of Measuring and Specifying Colour Rendering Properties of Light Sources* (CIE 13.3). Vienna, Austria.
- Classen, H.L., and C. Riddell. 1989. Photoperiodic effects on performance and leg abnormalities in broiler chickens. *Poultry Science* 68(7):873-879.
- Colon, A., and T. Torres. 2017. The best smart light bulbs of 2017. *PCMag.com*. January 9. <http://www.pcmag.com/article2/0,2817,2483488,00,asp>.
- Dahl, G.E., B.A. Buchanan, and H.A. Tucker. 2000. Photoperiodic effects on dairy cattle: A review. *Journal of Dairy Science* 83(4):885-893.
- DIN (Deutsches Institut für Normung). 2015. Optical Radiation Physics and Illuminating Engineering—Part 100: Melanopic Effects of Ocular Light on Human Beings—Quantities, Symbols and Action Spectra. DIN SPEC 5031-100:2015-08. Berlin, Germany.
- DOE (U.S. Department of Energy). 2013. *Hammer Testing Findings for Solid-State Lighting Luminaires*. Report prepared by RTI International for the U.S. Department of Energy. Washington, D.C. December.
- DOE. 2015. *Solid-State Lighting R&D Plan*. Washington, D.C. May.
- DOE. 2016a. *Chicago Round Table for Lighting Specifiers—Summary Report*. Washington, D.C.
- DOE. 2016b. *Solid-State Lighting R&D Plan*. Washington, D.C. June.
- Duke, W.B., R.D. Hagin, J.F. Hunt, and D.L. Linscott. 1975. Metal halide lamps for supplemental lighting in greenhouses: Crop response and spectral distribution. *Agronomy Journal* 67(1):49-53.
- Durmus, D., and W. Davis. 2015. Optimising light source spectrum for object reflectance. *Optics Express* 23(11):A456-A464.
- Figueiro, M.G. 2015. Individually tailored light intervention through closed eyelids to promote circadian alignment and sleep health. *Sleep Health: Journal of the National Sleep Foundation* 1:75-82.
- Figueiro, M.G. 2016. Delayed sleep phase disorder: Clinical perspective with a focus on light therapy. *Nature and Science of Sleep* 8:91.
- Figueiro, M.G., and M.S. Rea. 2012. Preliminary evidence that light through the eyelids can suppress melatonin and phase shift dim light melatonin onset. *BMC Research Notes* 5:221.
- Figueiro, M.G., J.D. Bullough, R.H. Parsons, and M.S. Rea. 2004. Preliminary evidence for spectral opponency in the suppression of melatonin by light in humans. *Neuroreport* 15:313-316.
- Figueiro, M.G., A. Bierman, and M.S. Rea. 2008. Retinal mechanisms determine the subadditive response to polychromatic light by the human circadian system. *Neuroscience Letters* 438:242-245.
- Figueiro, M.G., A. Bierman, and M.S. Rea. 2013. A train of blue light pulses delivered through closed eyelids suppresses melatonin and phase shifts the human circadian system. *Nature and Science of Sleep* 5:133-141.
- Figueiro, M.G., B. Plitnick, A. Lok, G.E. Jones, P. Higgins, T.R. Hornick, and M.S. Rea. 2014. Tailored lighting intervention improves measures of sleep, depression and agitation in persons with Alzheimer's disease and related dementia living in long-term care facilities. *Clinical Interventions in Aging* 9:1527-1537.
- Figueiro, M.G., L. Sahin, B. Wood, and B. Plitnick. 2016. Light at night and measures of alertness and performance: Implications for shift workers. *Biological Research for Nursing* 18:90-100.
- Forbes, J.M. 1982. Effects of lighting pattern on growth, lactation and food intake of sheep, cattle and deer. *Livestock Production Science* 9(3):361-374.
- Gavin, J. 2014. Totally tubular: Linear LEDs. *Electrical Contractor*. February. <http://www.ecmag.com/section/lighting/totally-tubular-linear-leds>.
- GE Lighting. 2014. "LED T8 Tubular Lamps." October. http://www.gelighting.com/LightingWeb/emea/images/LED-T8-Tubular-Lamps-Data-sheet-EN_tcm181-67008.pdf.
- Grau, A. 2015. How to build a safer Internet of Things. *IEEE Spectrum*. February 25. <http://spectrum.ieee.org/telecom/security/how-to-build-a-safer-internet-of-things>.
- Grobe, L., A. Paraskevopoulos, J. Hilt, D. Schulz, F. Lassak, F. Hartlieb, C. Kottke, V. Jungnickel, and K.-D. Langer. 2013. High-speed visible light communication systems. *IEEE Communications Magazine* 51(12):60-66.
- Halper, M. 2016. Warning: The IoT is not secure. *LEDs Magazine*. February 2. <http://www.ledsmagazine.com/articles/2016/02/warning-the-iot-is-not-secure.html>.

- Harbers, G., and S. Manney. 2014. 'Internet of Lights' meets Industrial Internet of Things. *Photonics Media*. November. <https://www.photonics.com/Article.aspx?AID=56860>.
- Helson, V.A. 1965. Comparison of gro-lux and cool-white fluorescent lamps with and without incandescent as light sources used in plant growth rooms for growth and development of tomato plants. *Canadian Journal of Plant Science* 45(5):461-466.
- Hill, J.S. 2016. Cree continues to reinvent LED street lighting. *Clean Technica*. April 20. <http://cleantechnica.com/2016/04/20/cree-continue-reinvent-led-street-lighting/>.
- IDA (International Dark-Sky Association). 2010. *Visibility, Environmental, and Astronomical Issues Associated with Blue-Rich White Outdoor Lighting*. Tucson, Ariz.
- IEC (International Electrotechnical Commission). 2014. Digital Addressable Lighting Interface—Part 102: General Requirements—Control Gear. IEC 62386-102:2014. Geneva, Switzerland.
- IES (Illuminating Engineering Society). 2008. *Light and Human Health: An Overview of the Impact of Light on Visual, Circadian, Neuroendocrine and Neurobehavioral Responses*. TM-18-08. New York.
- IES. 2015. IES Method for Evaluating Light Source Color Rendition. TM-30-15. New York.
- Jost-Boissard, S., M. Fontoynt, and J. Blanc-Gonnet. 2009. Perceived lighting quality of LED sources for the presentation of fruit and vegetables. *Journal of Modern Optics* 56(13):1420-1432.
- Kim, S.J., E.J. Hahn, J.W. Heo, and K.Y. Paek. 2004. Effects of LEDs on net photosynthetic rate, growth and leaf stomata of chrysanthemum plantlets in vitro. *Scientia Horticulturae* 101(1):143-151.
- LaMonica, M. 2014. Philips creates shopping assistant with LEDs and smart phone. *IEEE Spectrum*. February 18. <http://spectrum.ieee.org/tech-talk/computing/networks/philips-creates-store-shopping-assistant-with-leds-and-smart-phone>.
- LEDs Magazine*. 2014. How do plug-and-play T8s stack up against ballast-bypass LED lamps? July 22. <http://www.ledsmagazine.com/articles/print/volume-11/issue-6/features/led-tubes/how-do-plug-and-play-t8s-stack-up-against-ballast-bypass-led-lamps.html>.
- Lewin, S. 2014. LEDs bring new light to car-to-car communication. *IEEE Spectrum*. August 20. <http://spectrum.ieee.org/transportation/advanced-cars/leds-bring-new-light-to-car-to-car-communication>.
- Lewis, P.D., R. Danisman, and R.M. Gous. 2008. Illuminance, sexual maturation, and early egg production in female broiler breeders. *British Poultry Science* 49(6):649-653.
- Lichtenhaler, H. 1987. Chlorophylls and carotenoids: Pigments of photosynthetic biomembranes. *Methods in Enzymology* 148:350-382.
- Los Angeles Bureau of Street Lighting. 2014. The City of Los Angeles LED Streetlight Replacement Program. February 24. <http://bsl.lacity.org/led.html>.
- McCree, K.J. 1972. The action spectrum, absorptance and quantum yield of photosynthesis in crop plants. *Agricultural Meteorology* 9:191-216.
- Miller, N.J. 2013. Managing Risks: Flicker. Paper presented at the DOE SSL Market Introduction Workshop, Portland, Ore., November 12-14.
- Moore, N. 2016. Smart home' security flaws found in popular system. *Phys.org*. May 2. <https://phys.org/news/2016-05-smart-home-flaws-popular.html>.
- Murthy, A., D. Han, D. Jiang, and T. Oliveria. 2015. Lighting-enabled smart city applications and ecosystems based on the IoT, pp. 757-763 in *2015 IEEE 2nd World Forum on Internet of Things (WF-IoT)*. <http://www2.cs.uh.edu/~donny/papers/lighting-wfiot2015.pdf>.
- Narendran, N., and Y. Liu. 2015. LED Life versus LED System Life. Paper 62-2 in SID '15 Digest of Technical Papers, SID Display Week 2015: International Symposium, Seminar and Exhibition, May 31-June 5.
- Narendran, N., J.P. Freyssonier, and Y. Zhu. 2015. Energy and user acceptability benefits from improved illuminance uniformity of parking lot illumination. *Lighting Research and Technology* 48(7):789-809.
- Narendran, N., Y. Liu, X. Mou, D. Thotagamuwa, and O. Eshwarage. 2016. Projecting LED Product Life Based on Application. Paper No. OP220-28 in *Fifteenth International Conference on Solid State Lighting and LED-based Illumination Systems*. SPIE Optics and Photonics. August 28 to September 1.
- NEMA (National Electrical Manufacturers Association). 2016. "Phase-Cut Dimming for Solid State Lighting—Basic Compatibility." SSL 7A. Rosslyn, Va.
- NGLIA (Next Generation Lighting Industry Alliance). 2014. *LED Luminaire Lifetime: Recommendations for Testing and Reporting*. Third edition. September. http://energy.gov/sites/prod/files/2015/01/f19/led_luminaire_lifetime_guide_sept2014.pdf.
- NRC (National Research Council). 2013. *Assessment of Advanced Solid-State Lighting*. Washington, D.C.: The National Academies Press.
- O'Malley, L. 2015. Smart lighting: The gateway to the connected home and IoT markets. *MaRS Discovery District*. September 29. <https://www.marsdd.com/news-and-insights/smart-lighting-the-gateway-to-the-connected-home-and-iot-markets/>.
- Ohno, Y. 2005. Spectral design considerations for white LED color rendering. *Optical Engineering* 44(11):111302-111302.
- Ohno, Y., and M. Fein. 2014. Vision experiment on acceptable and preferred white light chromaticity for lighting. Pp. 192-199 in *Proceedings of CIE 2014 Lighting Quality & Energy Efficiency, Kuala Lumpur, Malaysia*. CIE x039:2014. <http://www.cie.co.at/index.php/Publications>.
- Ohno, Y., M. Fein, and C. Miller. 2015. Vision experiment on chroma saturation for color quality preference. Pp. 60-69 in *Proceedings of the 28th Session of the CIE, 28 June – 4 July 2015, Manchester, United Kingdom*. CIE 216:2015. <http://www.cie.co.at/index.php/Publications>.
- OSRAM. 2015. OSRAM SYLVANIA Unveils OmniPoint—The Future of Flexible Controllable Light—at LIGHTFAIR International. May 5. <https://www.osram-america.com/en-us/newsroom/press-releases/Pages/OSRAM-SYLVANIA-Unveils-OmniPoint-the-Future-of-Flexible-Controllable-Light-at-LIGHTFAIR-International.aspx>.
- Peters, R.R., L.T. Chapin, K.B. Leining, and H.A. Tucker. 1978. Supplemental lighting stimulates growth and lactation in cattle. *Science* 199(4331):911-912.
- Phillips, C.J.C., and T.M. Arab. 1998. The preference of individually-penned cattle to conduct certain behaviours in the light or the dark. *Applied Animal Behaviour Science* 58(1):183-187.
- Poplawski, M. 2013. Managing Risks: Dimming. Paper presented at the DOE SSL Market Introduction Workshop, Portland, Ore., November 12-14.
- Prayitno, D.S., C.J. Phillips, and D.K. Stokes. 1997a. The effects of color and intensity of light on behavior and leg disorders in broiler chickens. *Poultry Science* 76(12):1674-1681.
- Prayitno, D.S., C.J. Phillips, and H. Omed. 1997b. The effects of color of lighting on the behavior and production of meat chickens. *Poultry Science* 76(3):452-457.
- Pruitt, S. 2015. What 'other' LED application will win in the next 5 years? *Strategies Unlimited*. September 14. <http://www.strategies-u.com/articles/2015/09/what-other-led-application-will-win-in-the-next-5-years0.html>.
- Rea, M.S., and J.P. Freyssonier. 2013. White lighting. *Color Research and Application* 38(2):82-92.
- Rea, M.S., M.G. Figueiro, J.D. Bullough, et al. 2005. A model of photo-transduction by the human circadian system. *Brain Research Reviews* 50:213-228.
- Royer, M.P. 2013. Managing Risk: Color Shift. Paper presented at the DOE SSL Market Introduction Workshop, Portland, Ore., November 12-14.
- Sahin, L., and M.G. Figueiro. 2013. Alerting effects of short-wavelength (blue) and long-wavelength (red) lights in the afternoon. *Physiology and Behavior* 116-117:1-7.
- Scigliano, E. 2013. Seattle's new LED-lit streets: Blinded by the lights. *Crosscut.com*. March 18. <http://crosscut.com/2013/03/streetlights-seattle-led/>.

- Smalley, E. 2013. Insights from Installations: City of Seattle LED Street Lighting Conversion. Paper presented at 2012 DOE Solid-State Lighting R&D Workshop, Atlanta, Ga., January 31 to February 2.
- Taylor, N., N. Prescott, G. Perry, M. Potter, C. Le Sueur, and C. Wathes. 2006. Preference of growing pigs for illuminance. *Applied Animal Behaviour Science* 96(1):19-31.
- Thapan, K., J. Arendt, and D.J. Skene. 2001. An action spectrum for melatonin suppression: Evidence for a novel non-rod, non-cone photoreceptor system in humans. *Journal of Physiology* 535:261-267.
- Thompson, M.D.R. 2007. Psychophysical evaluations of modulated color rendering for energy performance of LED-based architectural lighting. Doctoral dissertation. Massachusetts Institute of Technology, Cambridge, Mass.
- Tsao, J.Y., M.H. Crawford, M.E. Coltrin, A.J. Fischer, D.D. Koleske, G.S. Subramania, G.T. Wang, J.J. Wierer, and R.F. Karlicek. 2014. Toward smart and ultra-efficient solid-state lighting. *Advanced Optical Materials* 2(9):809-836.
- Weber, C.L., and H.S. Matthews. 2008. Food-miles and the relative climate impacts of food choices in the United States. *Environmental Science and Technology* 42(10):3508-3513.
- Weissman, D. 2014. LEDs: Taking control. *Architectural Lighting*. December 8. http://www.archlighting.com/technology/leds-and-taking-control_o.
- Williams, A. 2012. A meta-analysis of energy savings from lighting controls in commercial buildings. *Leukos* 8(3):161-180.
- Wood, B., M.S. Rea, B. Plitnick, and M.G. Figueiro. 2013. Light level and duration of exposure determine the impact of self-luminous tablets on melatonin suppression. *Applied Ergonomics* 44:237-240.
- Young, C.R., G.E. Jones, M.G. Figueiro, S.E. Soutière, M.W. Keller, A.M. Richardson, B.J. Lehmann, and M.S. Rea. 2015. At-sea trial of 24-h-based submarine watchstanding schedules with high and low correlated color temperature light sources. *Journal of Biological Rhythms* 30:144-154.

ANNEX 4.A SUBCOMPONENTS OF AN SSL PRODUCT

SSL products in the commercial market employ a variety of LED white light sources, including an array of phosphor-converted LEDs (blue LED chips covered by a coating of phosphor); an array of cool white (i.e., high color temperature) LEDs combined with red LEDs to create a warmer white and feedback control to maintain light output and color; and an LED array with a mixture of multicolored (red, green, blue, etc.) LEDs. These LEDs or LED arrays are mounted on a heat sink to minimize the heat at the LED junction(s) and are powered by an electronic driver that produces power of the form required by the LED. In some cases, secondary optics are used to direct the beam in a specific manner. If the LEDs are packaged as an integral lamp to replace a traditional light source, the lamp envelope (i.e., glass bulb) is designed to mimic the form of the traditional source and includes a specific connector (e.g., an American National Standards Institute [ANSI] standard base).

LED and LED Array

As described in Chapter 3, white LEDs are commonly made by dispersing phosphor(s) in the encapsulant surrounding the blue (or near-ultraviolet) LED chip. The process of combining phosphors with the LED chip has evolved over the years. Some packages still use the original method of mixing phosphor(s) into an epoxy or silicone medium. Other packages use a layer of phosphor coated on the chip, while newer LED packages and products consist of phosphor layer(s) separated from the LED chip(s), commonly referred to as a remote-phosphor LED or product (Hoelen et al., 2008; Narendran et al., 2005). Remote phosphor-type LEDs minimize heat-induced efficiency loss in phosphors (provided the phosphor conversion efficiency is not very low as well as the absorption of phosphor-converted photons by the blue LED chip). An LED array is created by mounting and interconnecting individual LED devices on a printed circuit board, which is then connected thermally to the heat sink.

OLED Panel

A unique feature of OLED lighting is that the device itself can form the installable fixture, because of its ability to be fabricated on any particular substrate or shape. Indeed, OLEDs can be fabricated directly on plastic blocks, flexible metal or plastic foils, or glass. In its configuration as an area lighting source, as discussed in Chapter 3, the luminaire itself operates without a significant increase in temperature above the room ambient. That is, in appropriately packaged devices, at a high surface luminance of 3,000 cd/m², the luminaire temperature rise can be only a few degrees centigrade, creating no local or distributed heat load on the room environment.

Secondary Optics

In an LED lighting product, secondary optics are needed to tailor the output beam of a lighting product. LED products commonly designed for illumination applications have LEDs arranged in several different ways together with secondary optics. These designs include an LED array placed inside reflector(s) and behind total internal reflection (TIR) lenses. These methods help the collection and distribution of light in a specific manner. Refractive optics, commonly referred to as lenses, reflective optics, or reflectors, are generally designed as non-imaging optics to be used in illumination products for beam shaping. Researchers have designed and used complex optics to achieve difficult beam shapes (Tsais and Hung, 2011). Typically, no secondary optics are required for OLED panels.

Reliability of Optics

Lens materials are usually made from glass, polymers, epoxies, or silicones. Material selection is very important, especially when designing long-life products. Some optical materials degrade when exposed to radiation (more specifically, short wavelengths like ultraviolet and “blue” radiation) and heat. This spectrally dependent light output deterioration is one of the main ways that LEDs degrade.

Thermal Management

Thermal management is very important to enable reliable, long-life LED products, and the thermal management components in an LED product constitute a large fraction of product cost. A high-temperature LED junction can negatively impact LED life and optical performance, and as discussed in Chapter 3 in Annex 3.A, “An LED Primer,” this places considerable demands on the plastic lens and encapsulant material. At higher p-n junction temperatures, the amount of photons emitted decreases and the spectral power distribution shifts to longer wavelengths. Furthermore, the degradation of the encapsulant and the LED chip, over time, decreases the luminous flux. Electrical energy not converted to light contributes to the heat at the p-n junction. To keep the LED junction temperature low, all heat transfer methods, including conduction, convection, and radiation, must be considered. Heat conducted to the environment from the p-n junction encounters several interfaces and layers. Therefore, to keep the junction temperature low, the thermal resistance of every layer and interface must be very low.

Thermal Management Component and Strategies

An LED chip is typically encapsulated in a transparent material, such as epoxy, polymer, or silicone. These materials have very low thermal conductivities. As a result, the majority of the heat produced at the p-n junction is conducted

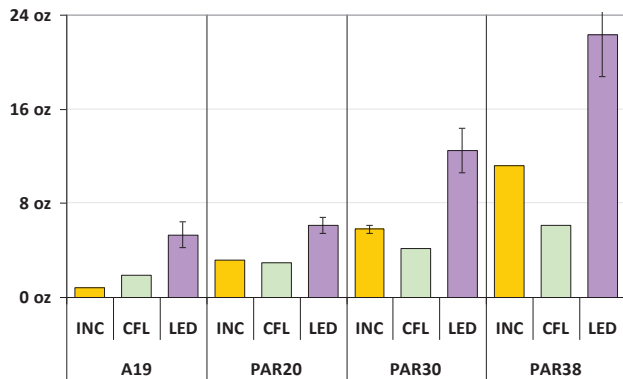

FIGURE 4.A.1 Weight comparisons among incandescent (INC), compact fluorescent (CFL), and LED lamps for A19, PAR20, PAR30, and PAR38 lamp types. SOURCE: N. Narendran, Y. Gu, J.P. Freyssinier-Nova, and Y. Zhu. 2005. Extracting phosphor-scattered photons to improve white LED efficiency. *Physica Status Solidi A* 202(6):R60-R62.

through the metal substrate below the chip and not through the transparent encapsulant. Usually, a high-power LED is mounted on a metal-core printed circuit board (MCPCB). When creating a product, an LED (or an array of LEDs) mounted on an MCPCB is attached to a metal heat sink using a TIM. Usually these heat sinks have extended surfaces, such as fins, which dissipate the heat to the environment by convection and radiation. Currently, a few manufacturers have started to mount the LED directly onto the heat sink to further reduce the thermal resistance from the junction to the environment and also to reduce the overall cost.

Common thermal interface materials are solder, epoxy, thermal grease, and pressure sensitive adhesive. Parameters that can influence thermal resistance include surface flatness and quality of each component, the applied mounting pressure, the contact area, and the type of interface material and its thickness. Adding conducting particles and carbon nanotubes (CNTs) to TIM to reduce thermal resistance has been studied (Fabris et al., 2011).

Most manufacturers exploit both conduction and convection methods to reduce LED junction temperature. Usually the heat sinks have a very large metal surface area, and, as a result, the integral lamp or the entire luminaire is much heavier than its traditional counterpart. Figure 4.A.1 shows typical weights for incandescent, CFL, and LED lamps of different types.

To make the weight of LED products comparable to traditional lamps, lightweight materials, like polymers and composites, with very high thermal conductivity are needed. The thermal conductivity of plastic materials can be increased by using fillers such as ceramics, aluminum, graphite, and so on. Injection-molded polymer parts of high thermal conductivity are an economical approach for cool-

ing high-power LED products. Some also have investigated techniques such as heat pipes, like those used in computers, to keep LED junctions cooler.

While these passive cooling methods work well for certain types of SSL products, higher power LED lighting products (1,500 lumens and above) pose significant thermal management challenges. Passive heat sinks are not sufficient to keep the LED junction sufficiently cool. Therefore, to achieve desired lumen values in a small form factor (e.g., A-lamp, PAR lamp, MR16, etc.), active cooling may be required to dissipate the heat. Even though mechanical fans have been used in some high-power LED lighting products,¹ they are not desirable for many reasons, including short life, acoustic noise, attraction of dust, and increased energy use. Over the past several years, other active cooling techniques have been investigated for managing the heat in high-power electronics, including synthetic jet and piezoelectric fan technologies. Synthetic jet technology uses a moving diaphragm that produces air movement by suction and ejection of air. Rapidly fired pulses of air are directed to where cooling is needed, such as heat sink fins, to improve cooling efficiency. Piezoelectric fans have several advantages, including longer life, lower acoustic noise, and lower power demand (Zhang et al., 2011). These techniques have shown promise and are worthwhile for further development for high-power LED cooling (Acikalin et al., 2007). Even though active cooling may be necessary for some products in some applications, for the majority of the applications, passive cooling is more desirable.

There is a strong interaction among LED device efficacy, the requirement placed on the thermal management system, and the cost of SSL. Increased efficacy reduces the heat generated per lumen, allowing either a shrinking of the necessary heat sink, and thus a reduction in cost and weight, or an increase in lumen output for the same physical luminaire.

References for Annex 4.A

- Acikalin, T., S.V. Garimella, A. Raman, and J. Petrosk. 2007. Characterization and optimization of the thermal performance of miniature piezoelectric fans. *International Journal of Heat and Fluid Flow* 28(4):806-820.
- Fabris, D., M. Rosshirt, C. Cardenas, P. Wilhite, T. Yamada, and C.Y. Yang. 2011. Application of carbon nanotubes to thermal interface materials. *Journal of Electronic Packaging* 133:020902.
- Hoelen, C., H. Borel, J. de Graaf, M. Keuper, M. Lankhorst, C. Mutter, L. Waumans, and R. Wegh. 2008. Remote Phosphor LED Modules for General Illumination: Toward 200 lm/W General Lighting LED Light Sources. Paper presented at the Eighth International Conference on Solid State Lighting. Bellingham, Wash.: SPIE.
- Narendran, N., Y. Gu, J.P. Freyssinier-Nova, and Y. Zhu. 2005. Extracting phosphor-scattered photons to improve white LED efficiency. *Physica Status Solidi A* 202(6):R60-R62.

¹ See Peters (2012) and Ecomaa Lighting, Inc., "New 80W LED PAR Lamp with Fan Inside," <http://ecomaa.en.ecplaza.net/ecomaa-new-80w-ledpar--258939-1872324.html>, accessed September 5, 2012.

- Peters, L. 2012. Are MR16 LED lamps ready for the 50W-halogen switch? *LEDs Magazine*. June.
- Tsais, Y.P., and C. Hung. 2011. Design of optical components for a light emitting diode zoom illumination system. *Optical Review* 18(2):224-230.
- Zhang, K., D.G.W. Xiao, X. Zhang, H. Fan, Z. Gao, and M.M.F. Yuen. 2011. Thermal performance of LED packages for solid state lighting with novel cooling solutions, pp.1/7-7/7 in *2011 12th International Conference on Thermal, Mechanical and Multi-Physics Simulation and Experiments in Microelectronics and Microsystems (EuroSimE)*. Piscataway, N.J.: Institute of Electrical and Electronics Engineers.

5

Manufacturing

INTRODUCTION

In the 3 years following the release of *Assessment of Advanced Solid-State Lighting* (NRC, 2013), the price of light-emitting diode (LED) lamps and luminaires has dramatically declined (see Figure 2.9). A dislocation of the LED market has been caused by significant oversupply created by the rise of a subsidized industry in China and the decline in the requirements for LEDs for the display market, due to the replacement of LED-lit liquid crystal displays (LCDs) by organic LED (OLED) displays in the hand-held market, and the need for a smaller number of higher-power LEDs in large LCD displays. LED-based lamps are now available for only a few dollars a lamp, with efficacies that are comparable or better than compact fluorescent lamps (CFLs). The cost and reliability of LED lamps and luminaires is signaling the end of incandescent bulbs, and replacement of fluorescent and other lighting, particularly in hospitality and retail. A restructuring of the solid-state lighting (SSL) industry has begun, precipitated by declining margins and a dissociation of the low-priced, high-volume commodity lighting business from the higher-profit-margin, lower-volume specialty lighting business. (See discussion in the section “Economic Drivers in the United States, Europe and Asia” below.) In addition, new applications of SSL (e.g., smart lighting and Li-Fi [Light Fidelity]) are providing new business opportunities for SSL manufacturers.

Key issues for SSL that relate to manufacturing include the supply chain, packaging (both at the package and luminaire level), system reliability, and lumen maintenance.

THE MANUFACTURING SUPPLY CHAIN AND ECONOMIC DRIVERS

LEDs

The supply chain is critical to the success of the manufacturing operation. Figure 5.1 shows a schematic of the

manufacturing supply chain. The LED manufacturing process (shown in blue) is comprised of a sequence of relatively independent manufacturing steps (e.g., wafer fabrication, packaging, etc.) that are performed in the United States or offshore, mostly in Asia (see Table 5.1). The first step in the manufacturing process is epitaxial growth—the growth of the active device layer on a substrate. Epitaxial growth is performed using metal-organic chemical vapor deposition (MOCVD) reactors, as described in the section, “An LED Primer,” in Chapter 3. Because it is a highly proprietary technology, wafer fabrication, which includes epitaxial growth active films on a substrate wafer (usually sapphire), wafer dicing, and contact metallization, is usually done in-house by SSL manufacturers to safeguard their know-how. LED device fabrication, although primarily an in-house operation, particularly for the manufacture of high-power (HP) LEDs, is largely located in Asia for cost and supply chain reasons. For mid-power (MP) and low-power (LP) LEDs, there is a parallel supply chain with merchant LED die providing low-cost die to the major lighting product manufacturers and to packaging companies (e.g., Lextar, Taiwan). By far the largest suppliers of MP and LP LEDs are Epi Star in Taiwan and San’an in China.

The type of LED packages—containing separate LED die, phosphors, and encapsulation—depends on the power rating and optical characteristics of the LED. Details of several common LED packages are discussed in the section, “Packaging and Packageless LEDs.” Initial LED packaging is usually done in-house because of the proprietary nature of phosphor application, light extraction, and heat sinking technology inherent to the package design. Final packaging and testing of the completed LED are done in-house or outsourced to contract manufacturing suppliers. These various stages of packaging are almost exclusively done in facilities located in Asia.

The wafer fabrication and LED packaging processes are supported by a chain of suppliers, including manufacturing

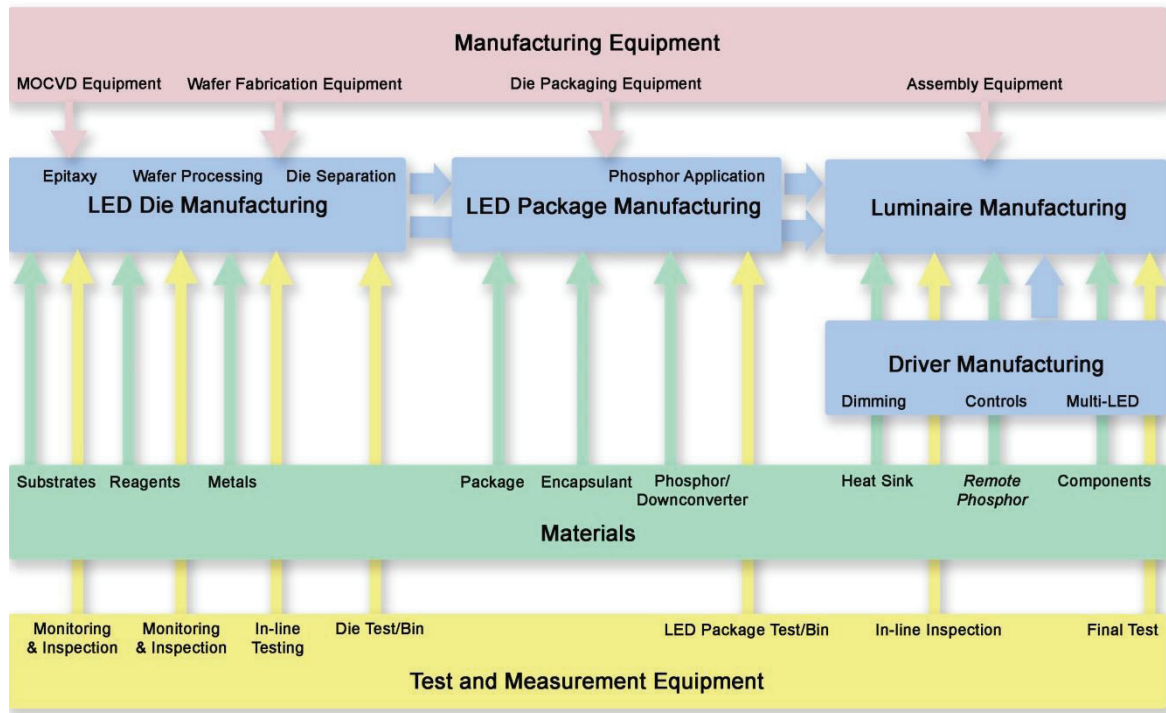

FIGURE 5.1 Light-emitting diode (LED)-based manufacturing supply chain. SOURCE: DOE (2015).

TABLE 5.1 Light-Emitting Diode (LED) Die, Packaging, and Luminaire Manufacturers

Supply Chain	North America	Europe	Asia			
Die manufacturing	<ul style="list-style-type: none"> • Cree • Lumileds • Bridgelux 	<ul style="list-style-type: none"> • Soraa • SemiLEDs • Luminus Devices 	<ul style="list-style-type: none"> • OSRAM Opto Semiconductors • Optogan • Plessey Semiconductors 	<ul style="list-style-type: none"> • Nichia • Toyoda Gosei • Toshiba • Sharp • Epistar • SemiLEDs Optoelectronics • MLS Lighting 	<ul style="list-style-type: none"> • OptoTech • FOREPI • Everlight • Lumens • Kingbright • Samsung 	<ul style="list-style-type: none"> • LG Innotek • Seoul Semiconductor • Elec-Tech Opto • Epilight • HC SemiTek • Sanan Optoelectronics
LED package manufacturing	As above	As above	<ul style="list-style-type: none"> • Lite-On • Unity Opto • Lextar 	<ul style="list-style-type: none"> • Nationstar • Shenzhen Jufei • Honlitrionic • Refond 		
Luminaire manufacturing	<ul style="list-style-type: none"> • GE Lighting • Eaton/Cooper Lighting • Hubbell Lighting • Soraa • MSi • Kim Lighting 	<ul style="list-style-type: none"> • Acuity Brands • Cree • Lighting Science Group • Feit 	<ul style="list-style-type: none"> • Phillips • OSRAM Sylvania • Zumtobel 	<ul style="list-style-type: none"> • Panasonic • Toshiba • Sharp • LG • Samsung • Forest Lighting 	<ul style="list-style-type: none"> • Kingsun • Zhejiang Yankon • Shenzhen Changfang • Opplle Lighting • PAK Corp • Nationstar • NVC Lighting Tech Corp • FSL 	

SOURCE: DOE (2016, p. 165).

equipment (shown in pink in Figure 5.1), testing (shown in yellow), and materials (shown in green).

There are several materials critical to LED manufacturing:

- *Substrates.* Substrates are the base material onto which the active layers are epitaxially grown. Substrates are 2 to 6 inches in diameter, with Sapphire growing to 8 inches and gallium nitride (GaN) available at 2 inches. In most cases, sapphire is the material of choice for the substrate, although some manufacturers use silicon carbide (SiC) and GaN.¹ Sapphire wafers are available from global suppliers in all regions. SiC wafers are primarily sourced from the United States and used for LEDs by Cree, Inc.
- *MOCVD precursors.* The MOCVD precursors are the chemicals that are reacted in the gas phase to produce the epitaxial films that form the active layer structure of the LED. These precursors are organometallic compounds, which are available from suppliers located in all regions and are sourced globally (i.e., externally) by major manufacturers.
- *Packaging materials.* The specific materials used for the packages are dependent on the package design. For HP LED packages, aluminum nitride (AlN, a ceramic material) is generally used. These materials are primarily sourced in Asia. For MP and LP LEDs, plastic packages with copper lead frames (to carry electrical signals to/from the die) are used, which are also primarily sourced in Asia.
- *Phosphor/down converters.* The phosphor is a chemical compound that emits light of a certain frequency when excited by a light “pump.” There are a broad range of source materials available to make up the phosphors used for LEDs. Some phosphors are sourced internally (i.e., within the company) by major manufacturers, while others are provided by commercial suppliers located across the regions. The phosphor composition is often proprietary to the LED manufacturer.
- *Encapsulation materials.* The encapsulation materials are used to enhance light extraction and protect the device and the phosphors from the environment. Encapsulation materials are primarily silicones. In LP and MP devices, the phosphor is integrated with the silicone. These materials are sourced globally and provided by a number of suppliers located across all regions.

PACKAGING AND PACKAGELESS LEDS

LED packages provide mechanical support, heat removal, and electrical contact. The term LED means the active light-

¹ Including freestanding GaN substrates (for example, those offered by Sora).

emitting device, which is the semiconductor device or the device covered with color conversion medium such as a phosphor. Packaging approaches have been developed for three broadly used categories of LEDs: (1) HP LEDs, which operate at power levels greater than 1 W; (2) MP LEDs, which operate at power levels between 0.25 W and 1 W; and (3) LP LEDs, which operate at less than 0.25 W. In addition, a new type of package technology called chip scale packaging (CSP; see the section, “Package-Free Technology,” below), also called package-free LEDs because they can be bonded directly to printed circuit boards, is gaining attention.

Low-Power and Medium-Power Packages

The largest quantities of LEDs used in illumination and LCD backlighting applications are of typically 0.5 W or lower power (i.e., MP or LP LEDs). These LEDs employ a device structure where light is emitted laterally through the edge of the die. With this structure, the light can more effectively couple into the phosphor converter. The schematic of the package is shown in Figure 5.2. The light emitted from the die travels into a plastic package “cup” with a silvered interior filled with phosphor material (shown in Figure 5.2b). The silvered cup also serves as a reflector to trap and couple the light to the phosphor. Due to its extremely low cost, this package is sometimes used for MP LEDs of powers higher than 0.5 W. Multiple lateral MP LED die can be arrayed together in a larger package, referred to as a “chip on board” (COB). These COBs have been rapidly gaining acceptance and created a lower cost solution compared to higher cost HP LEDs for directional lighting, such as polished aluminum reflector (PAR) lamps.

High-Power Packages

HP LEDs are packaged such that light is emitted from the top surface and are generally classed as “surface emitters.” In this design (shown in Figure 5.3), the sapphire substrate is removed from the epitaxially grown active layer, leaving a thin film of GaN containing the LED. The thin-film LED is then attached to a silicone, germanium, or ceramic carrier and covered in phosphor. The LED is then attached to a tile or interposer. This is the dominant packaging technology for HP LEDs, which can be implemented for flip-chip mounting, as shown in Figure 5.4. These architectures also often use a patterned sapphire substrate to improve light extraction.

Package-Free Technology

The CSP is a stand-alone package die, which can be bonded directly to a printed circuit board. The CSP technology is illustrated in Figure 5.5. In this design the patterning of the sapphire substrate allows the sapphire to remain on the die as a structural support, while at the same time allowing light to be extracted through the top of the device. The

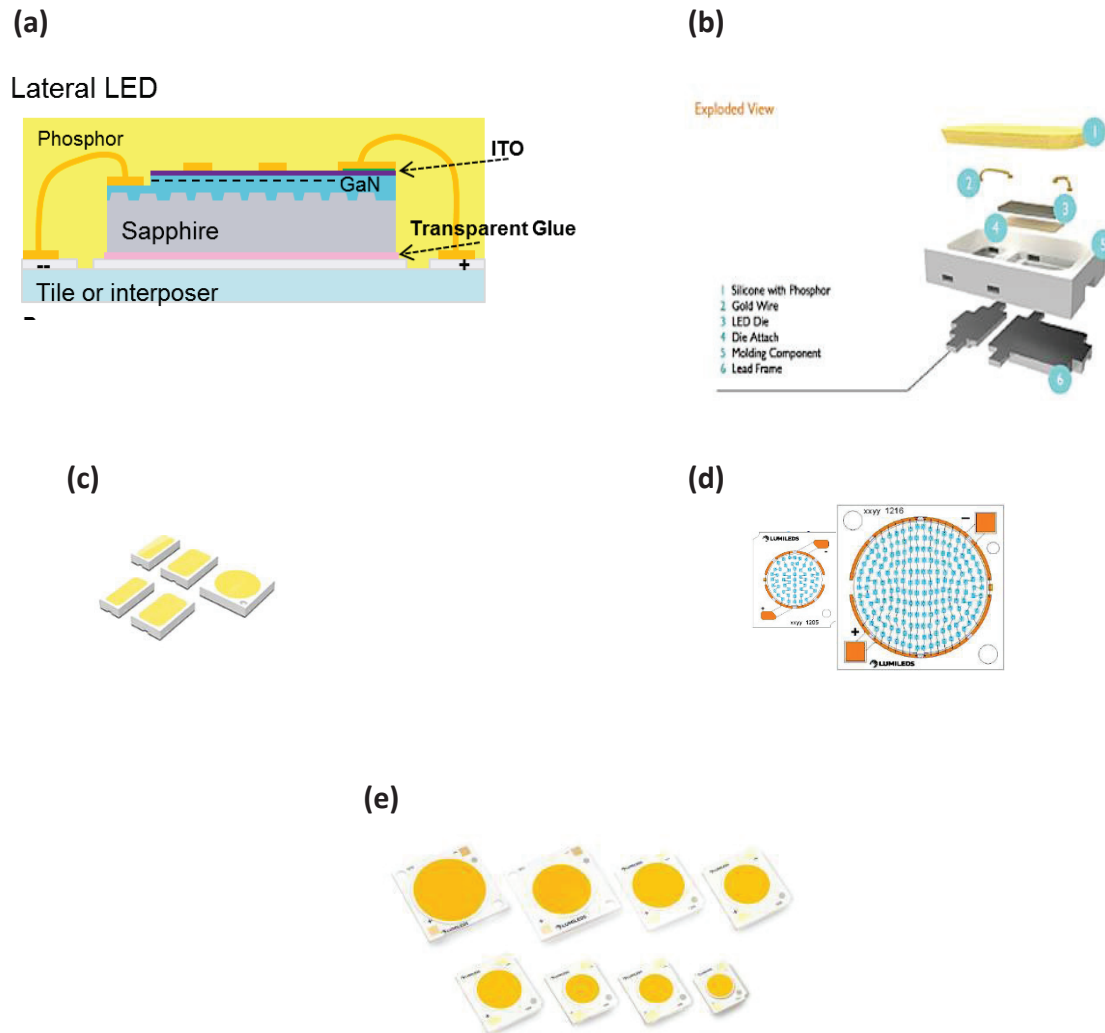

FIGURE 5.2 Lateral or edge-emitting package LED schematics. (a) mid-power (MP) or low-power (LP) light-emitting diode (LED) cross-section. The sapphire provides robust structure, and the low-cost package has the maximum extraction for non-directional applications. It is non-ideal for directional applications and has poorer heat sinking due to the use of transparent glue. The wire bond complicates phosphor integration; (b) MP/LP package schematic; (c) packaged MP/LP LED of varying sizes; (d) COB (chip-on-board) showing lateral die arrays; and (e) completed COB. NOTE: ITO = indium tin oxide. SOURCE: (a), (d), and (e) Courtesy of Lumileds; (b) and (c) Philips LSI Product Catalog, 2013 Version 1.0.

patterned sapphire substrate die has been critical in enabling CSP. These “package-free” die are low cost (compared with the thin film design in 5.3) and has a small size that can be packed at high density in a COB configuration as shown in 5.2d and operated at high power. This is the lowest cost packaging for HP LEDs.

A further advantage of this package is high device density, which results in a small light-emitting surface. The main disadvantage of the approach is that the light extraction efficiency is generally lower than the thin-film packages.

LAMPS AND LUMMINARES

The LED lighting industry is clearly separating the traditional lamp-based and luminaire-based business. Major

players have taken steps to divest their lamp-based business, or at least separate their lamp-based business from their luminaire-based business. The lamp-based products are now seen as a commodity business with low profitability and insufficient product differentiation from various manufacturers. The luminaire-based business is increasingly being viewed as a better opportunity to drive increased values through technology integration (connectivity) and design innovation. Examples of this trend are GE, which separated its lamps business from its luminaire business by creating two new business units (Black, 2015), and OSRAM, which created a separate company into which it divested its general lighting lamps business (Prodhan, 2015).

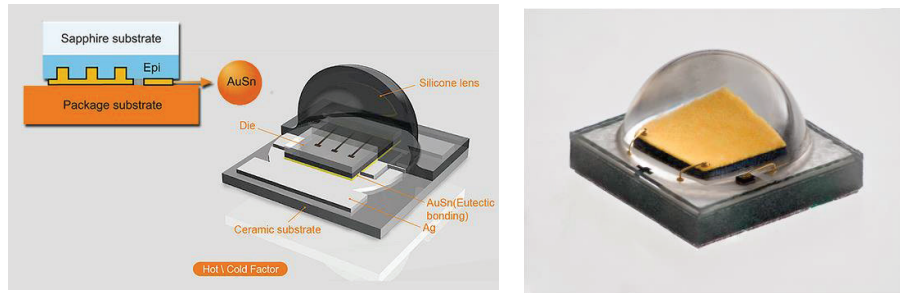
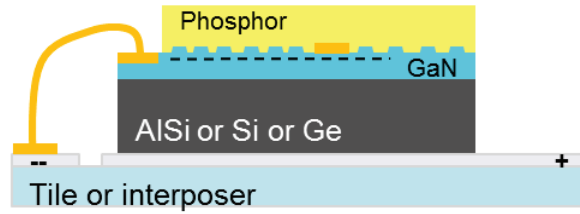
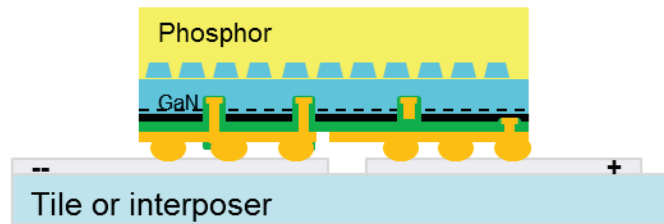

FIGURE 5.3 Vertical thin-film high-power (HP) light-emitting diode (LED) package. (a) Cross-section schematic. Advantages include high luminance light source for directional applications and an excellent heat sinking for HP applications. Nonetheless, the thin-film structure requires careful handling, and the wire-bond complicates phosphor integration. (b) Vertical thin-film HP LED. Schematic and final packaged HP LED with silicone dome. SOURCE: (a) Courtesy of Lumileds. (b) Courtesy of Cree.

(a)



(b)



FIGURE 5.4 Thin-film flip-chip (TFFC) package. (a) Cross-section of TFFC. The package provides high luminance light source for directional applications. The contact/heat-sinking does not interfere with the light emission. The thin-film structure requires careful handling. (b) Domed and undomed light-emitting diode (LED). SOURCE: Images courtesy of Lumileds.

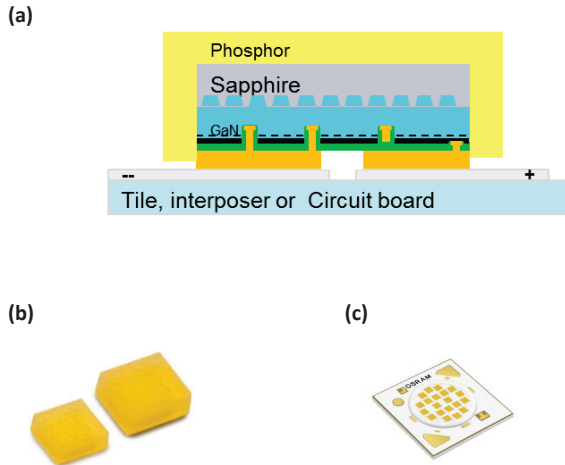

FIGURE 5.5 Chip scale package (CSP). (a) Cross-section of CSP. The contact/heat sinking does not interfere with light emission, and the sapphire provides robust structure for direct attachment; (b) 1 mm and 2 mm CSP parts for direct attachment; and (c) CSP-based arrays on boards—similar to chip-on-board, but with higher output. SOURCE: (a and b) Lumileds; (c) Osram GmbH.

Lamps/Lamp-Based Luminaires

LED lamps and LED lamp-based luminaires (luminaires with replaceable LED lamps) will continue to penetrate the general market because prices are currently low, even from top-tier manufacturers. It is expected that over time all conventional lamp types will be replaced by solid-state equivalents, including high-intensity discharge (HID) and linear fluorescent lamps. These conventional products offer little opportunity for differentiation.

In the LED lamp market, the focus is likely to be on further cost reduction. However, the investment in technology to drive the cost reduction is going to be limited, as the major players cannot realize appropriate returns. Instead, manufacturing of these commodity products has been moved to the lowest-cost locations. Already, LED lamp products are almost entirely manufactured in Asia. In spite of the limited investment in LED-based commodity lamps manufacturing, the price continues to decrease and the efficacy continues to rise, probably due to the fact that more-efficient LEDs are used along with smaller energy efficient electronics and smaller, more effective heat sinks.

FINDING: The domestic manufacturing of LED lamps and lamp-based luminaires is financially unattractive, as evidenced by U.S.-based manufacturers having either divested themselves of these product lines or segregated them operationally.

LED Luminaires (1st Generation)

Since the 2013 NRC report, the adoption of LED luminaires (luminaires with LED light engines²) has accelerated, particularly in areas such as outdoor, retail, hospitality, and industrial lighting. This financially attractive market is served by all SSL manufacturers, including many new entrants. It is being driven in part by specifications and regulations for energy efficient lighting in new installations and construction, as discussed in Chapter 2. This business space is becoming increasingly cost competitive and cannot indefinitely be viewed as a high-return business at the undifferentiated base-grade level.

Large-volume commercial and consumer luminaires are made in low-cost regions (see right-hand side of Figure 5.1). For specification- and architectural-grade luminaires, such as large, heavy outdoor fixtures, and low-volume professional configurable products, manufacturing is situated in regions close to the customer base, due to lead-time, shipping cost, and inventory management considerations. To this end, companies like GE and Philips are moving their manufacturing of these classes of products from the Far East back to North America.

LED Luminaires (Next Generation)

The next generation of LED luminaires will be defined by a combination of new design, performance, and control and connectivity features.

- Design (look and feel)—slim, transparent, unique form factor;
- Performance—light quality, control, efficacy; and
- Control and connectivity—integrating lighting functional control, other non-lighting features.

There is a strong belief that these products can reward innovation and offer differentiation. Often these luminaires will be low volume, highly customized, and project- or application-specific. The luminaire manufacturers can exploit the unique capabilities of LEDs to provide custom light appearance in retail applications as well as in adjacent markets of health care and horticulture. In addition, using luminaires based on edge-lit, light-guiding LEDs can create uniform light emitting surfaces similar to those created by OLED luminaires at a fraction of the cost. All these next-generation luminaires will be increasingly manufactured locally due to their complexity and customized features.

Luminaire product categories include the following:

- *Base grade*—products which meet limited specifications—often referred to as “consumer grade”;

² LED light engines are LEDs with integrated drive electronics and/or optics.

TABLE 5.2 Ranking of LED Manufacturers by Revenue: The Largest 10 Players in the LED Industry Saw Their Revenues Shrink or Stay Level

Rank	Company	Location	2015 Revenues (\$)	2015 Share (%)	Growth in \$USD (%)	Growth in Local Currency (%)
1	Nichia	Japan	2,297	15	-6	7
2	OSRAM Opto	United States/Europe	1,248	8	-4	15
3	Lumileds	United States/Europe	1,196	8	4	4
4	Samsung	South Korea	960	6	-18	-18
5	Seoul Semiconductor	South Korea	801	5	0	7
6	Cree	United States/Europe	655	4	-16	-16
7	LG Innotek	South Korea	625	4	-29	-24
8	Everlight	Taiwan	590	4	-6	-6
9	Mulinsen (MLS)	China	561	4	2	2

SOURCE: Stephanie Pruitt, 2016, presentation at Strategies in Light, Santa Clara, Calif., March 1-3.

- *Specification grade*—products that meet specifications higher than base grade and are generally designed for professional installation; and
- *Statement or architectural grade*—the highest performance products from the perspectives of both performance and design.

ECONOMIC DRIVERS IN THE UNITED STATES, EUROPE, AND ASIA

Globally, government support for manufacturing varies widely from country to country. In the United States and Europe, the support has been focused on R&D and targeted manufacturing technology improvements, which represents encouraging but not significant sums. In stark contrast, from 2009/10 to the present, China has disrupted the global balance of the LED industry through massive subsidies to its domestic producers. In particular, China has provided huge subsidies for MOCVD reactors—the capital equipment for epitaxial growth, resulting in massive overcapacity of LED production and a rapid decline in LED price in recent years. The LED industry now sees marginal and even “irrational” pricing (product sold below cost), which is becoming an unsustainable norm, as the Chinese government continues to bolster its domestic LED industry through subsidies. Industry consolidation appears to be inevitable with an increasing number of LED companies merging or failing in the Chinese market.

China has also influenced the supply chain in the past by restricting the export of rare earth elements used in the phosphors. The response was an uproar worldwide, which also helped create new mining operations for rare elements in Australia and the United States.

Few companies in the LED lamp business are growing. It remains questionable whether the lamp and lamp-based luminaire market will offer a return on investment attractive to these companies in the short to medium term, or even in the long term, due to the reduced replacement market and the long life of LEDs. The data in Table 5.2 clearly illustrates this conclusion, showing that only two companies experienced growth in U.S. dollar-denominated revenue in 2015.

The conclusion that LED companies are not growing in the illumination business is reinforced by the actions of EPI Star in its recent downsizing of production capacity (Wang, 2016) and its announcement that for the first time it will increase LED die prices in June and then in July 2016. San’an, the largest Chinese supplier, is also taking steps to increase prices. Such moves are indicating that LED manufacturers are unwilling to sell so far below cost just to maintain their market shares. Samsung, Philips, and others have taken actions in the past 2 years in restructuring their illumination-focused LED and lighting businesses.³ On the other hand, OSRAM (which separated from Siemens in 2013) has committed to investing heavily in the optoelectronics business with the belief that such investment in LED capacity and research will be justified in the long run (OSRAM, 2015).

To drive growth and profitability, LED companies are looking to high-value adjacent markets including infrared LEDs, ultraviolet LEDs, curing, connected lighting, horticulture, and medical applications. These adjacent markets are attractive as areas of potentially significant growth and profitability. Such technology-based markets in the past have been exploited with great success in the United States

³ The LED Lighting Exodus: Samsung Joins Philips and Siemens,” Memoori Smart Building Research, release date November 24, 2014.

through venture capital and entrepreneurial start-ups. SSL-based electronic products are an excellent fit to the venture model that relies on innovative product design and market acumen to drive new LED applications.

In addition to adjacent markets, the commercial and architectural luminaire business seems to be growing and remains financially attractive. Future markets, such as the Internet of Things, home and office controls, and ubiquitous information systems, are of great interest, and the luminaire may be an important hub for such systems. GE and other companies are enhancing their lighting businesses with development activities in these areas.

FINDING: Subsidies for China's LED industry from the Chinese government have significantly impacted the global LED market, driving an oversupply of LEDs and resulting in price collapse and a rapid shift to a commoditized industry.

FINDING: The commoditization of the illumination market for LEDs has created an environment that is challenging for the LED industry and offers, in the short to medium terms, an unattractive return on investment for companies with business in LEDs.

OLEDs

The cost of OLED SSL products remains high at 20 to 25 times the \$/lumen of comparable LED-based products. The capability of unique OLED products remains intriguing because, unlike LEDs that are a directional point source, the OLED is a diffuse-area light source distinguished by its spectral quality. Produced generally in the form of rigid or flexible tiles, OLED panels can be readily integrated to create luminaires without significant losses in efficacy or spectral quality. Because they are thin-film devices, OLEDs have the possibility of mass production by a high-speed, roll-to-roll process at a low cost. Compared to LED SSL products, OLED SSL products are in a very early stage of development, but they have made significant progress in that they are being produced by a number of manufacturers worldwide and sold in big-box stores. In terms of performance, commercial OLED SSL products have achieved an efficacy of 60 to 65 lm/W and a lifetime (L70) of 40,000 hours operating at a nominal surface luminance of 3,000 cd/m².

OLED-SSL Products

Currently, the OLED-SSL business is very small compared to the LED SSL business. Worldwide, there are fewer than a dozen OLED panel manufacturers and even fewer OLED luminaire makers. LG Display of Korea, with business mainly in LCD and OLED displays, is the leading

OLED-SSL manufacturer, after it acquired the OLED-SSL business from LG Chem in 2015. OLEDWorks is the sole OLED-SSL manufacturer in the United States. Begun as an R&D enterprise in Rochester, New York, it became a global OLED-SSL manufacturer after acquiring the OLED-SSL business and manufacturing facilities from Philips of Germany in 2015. Konica-Minolta, First-O-Lite, and OSRAM are other key players in Japan, China, and Germany, respectively. In Table 5.3, representative OLED-SSL products from these and other manufacturers are listed along with their product specifications.

It can be seen that there are significant variations in the key performance metrics—efficacy and lifetime—among OLED-SSL products from various manufacturers, reflecting that OLED products are far from standardized, and their commercialization is still at an early stage. The highest efficacy is 60 to 65 lm/W (by LGD and First-O-Lite), and the longest lifetime (L70) is 40,000 to 50,000 hours (by LGD and Kaneka) for nominal operation of about 3,000 cd/m² in surface luminance. The color rendering index for OLED-SSL is generally high, ranging from 80 to more than 90 for all products. The drive voltage varies over a large range (from 6 V to over 20 V) due to the adoption of various tandem structures in OLED-SSL products. LGD products have a 2- or 3-stack tandem structure, which requires a drive voltage of 6.1 V and 8.5 V, respectively, whereas OLEDWorks products incorporate a six-stack tandem structure, resulting in a much higher drive voltage of 20 V (and also a proportionally higher luminance). While the adoption of tandem structures is essential to achieving high brightness and long lifetime in OLED-SSL products, it also incurs extra cost in manufacturing due to the increased complexity of the tandem structures and the requirement of extra deposition chambers.

OLED-SSL Product Cost

The high cost of OLED-SSL products has been the key barrier to their adoption for general lighting applications. While the cost of conventional LED-SSL products has dropped precipitously and their mass adoption is being rapidly realized, the cost of OLED-SSL products has remained extraordinarily high by comparison, and their utility so far is limited to specialty lighting. In benchmarking the lumen cost of LED and OLED products, the customary metric dollar per kilo-lumen (\$/klm) is used. Table 5.4 lists the high, low, and average lumen cost values for 10 LED-SSL edge-lit panel products available today from Amazon.com. For comparison, the costs of four OLED-SSL products (two from Acuity Brands sold at Home Depot and two from the OLEDWorks catalog) are also listed.

The high cost of OLED-SSL is largely due to the high cost of manufacturing OLED panels. A recent study by Bardsley has provided an estimate of the breakdowns of the

TABLE 5.3 Comparison of LED and OLED Product Specifications

Company:	LGD	LGD	LGD	OLEDWorks	OSRAM	Kaneka	Lumiotec	Mitsubishi Chemical	First-O-Lite
Product Model:	N6SD30C	P6BD30A	FL300	SDW058	KNPP4BF3 0	P04B0405L A13A	Velve 52800	FOLB002	
Substrate type	Glass	Plastic	Glass	Glass	Glass	Glass	Glass	Glass	Glass
Shape	Square	Rectangle	Square	Square	Square	Square	Square	Rectangle	Rectangle
Lit size (mm × mm)	300 × 300	41 × 394.2	102 × 102	105 × 105	80 × 80	125 × 125	123 × 123	102.4 × 47.5	
Lit area (m ²)	0.0900	0.0162	0.0104	0.011	0.0064	0.0156	0.0151	0.0048	
Flux (lumen)	800	150	300	68	60	145	48	45	
Efficacy (as quoted) (Lm/W)	600	50	40-50	40	42	none	31	65	
CCT (Deg K)	3,000	3,000	3,000	3,400	3,000	2,800	2,700-6,500	3,000	
CRI	90	85	80	80	86	80	>80	>90	
LT70 (as quoted) (Hr)	40,000	20,000	10,000	10,000	50,000	10,000	20,000	20,000	
DC volt (V)	8.5	6.1	20	6	6.8	8	24	8.6	
DC current (mA)	1600	490	358	285	210	450	110	80.8	
Power (W)	13.60	2.99	7.16	7.71	1.43	3.60	2.64	0.69	
Current density (Cal) (mA/cm ²)	1.78	3.03	3.44	2.59	3.28	2.88	0.73	1.67	
Luminance (cd/m ²)	2829	2954	9178	1975	2984	2954	1010	2960	

NOTE: LGD = LG Display.

TABLE 5.4 Comparison of the Lumen Cost Between Light-Emitting Diode (LED) and Organic Light-Emitting Diode (OLED) Solid-State Lighting (SSL) Products

High-Low and Average of \$/klm	High	Low	Average
LED SSL (luminaires) ^a	50.6	17.5	33.5
OLED-SSL (mix of luminaires and lamps)	1463	237	735.1

^a Edge-lit panel.

various costs associated with the manufacture of OLED-SSL products.⁴

Table 5.5 shows the projected cost reductions from 2014 to 2025, assuming essentially the economy of scale in terms of large increases in production capability and lowering the bill of materials. These assumptions include the scaling of the factory size from the current Generation 2 (G2) factory for substrate area of 0.17 m² to the G8 factory for substrate area of 5.5 m². The overall cost reduction goal is almost 20

growth in the OLED display industry. The most recent (4Q 2015) cost estimate for a 5” full-high-definition active-matrix OLED (FHD AMOLED) display (for smartphones) by IHS is \$14.30, which is—for the first time—lower than the cost of an equivalent LCD display. Using this cost figure and assuming conservatively that one-third of the AMOLED panel cost is due to the OLED component (i.e., excluding thin film transistor backplane, drivers, red, green, blue pixelation), the cost of the OLED component is \$697/m² or 74 \$/klm in terms of lumen cost. Based on this cost assessment and assuming that OLED-SSL is equivalent to or no more expensive than the OLED component of the AMOLED display, Bardsley’s 2015 cost target of \$1,850/m² or 196 \$/klm for OLED-SSL products has been more than substantiated. However, the cost of OLED-SSL products remains too high to be competitive with today’s LED-SSL products. Further steep cost reductions, as targeted in Bardsley’s report, will be needed for OLED-SSL products to emerge as a viable business in general or specialty lighting sectors.⁵

TABLE 5.5 The Department of Energy’s Cost Reduction Goals

	2014	2015	2017	2020	2025
Substrate area	0.17	0.17	1.38	2.7	5.5
Capital cost (\$ million)	75	75	200	300	400
Cycle time (minutes)	3	2	2	1	1
Capacity (1,000 m ² /year)	14	25	300	1,000	2,400
Depreciation (\$/m ²)	1,050	600	125	60	35
Organic materials	200	150	100	35	15
Inorganic materials	200	200	120	50	30
Labor	150	100	20	10	5
Other fixed costs	75	50	15	10	5
Total (unyielded) (\$/m ²)	1,675	1,100	355	160	90
Yield of good product (%)	50	60	70	80	90
Total cost (\$/m ²)	3,350	1,850	550	200	100

SOURCE: J.N. Bardsley, 2016, “OLED Manufacturing Challenges,” presented at DOE Solid-State Lighting R&D Workshop, Raleigh, N.C., February 3.

fold from \$1,850/m² in 2015 to \$100/m² in 2025. In terms of lumen cost (assuming a Lambertian emitter of 3,000 cd/m²), the equivalent reduction is from 196 \$/klm to 10.6 \$/klm. It is interesting to note that the estimated value of 196 \$/klm for 2015 from Bardsley is in approximate agreement with the low-end cost value of 237 \$/klm for OLED-SSL products in Table 5.5.

It is expected that the cost of OLED-SSL products will continue to fall in future years as a result of the explosive

FINDING: Very aggressive manufacturing cost reductions will be necessary for OLED-SSL to be a successful entrant to the general lighting markets in the near future.

OLED-SSL Manufacturing

The manufacturing supply chain for OLEDs mainly includes equipment for thin-film deposition and encapsulation and chemical materials for the OLED layers. Asian companies are clearly dominant in the area of equipment, although there are some recent notable entries from the

⁴ J. Norman Bardsley, 2016, “OLED Manufacturing Challenges,” presented at DOE Solid-State Lighting R&D Workshop, Raleigh, N.C., on February 3.

⁵ Ibid.

TABLE 5.6 Major Companies in OLED Manufacturing

Category	Companies
Deposition/ Encapsulation	Cannon Tokki, Ulvac, Seiko Epson, AP Systems, Sunic, SNU, SFA Engineering, AMAT, Kateeva, Axitron
Materials	Samsung SDI, LG Chemical, Dooson, SFC, Duksan, Idemitsu Kosan, Hodogaya, Toyo Ink, UDC, Dow Chemicals, Merck

United States, whereas the chemical business is more globally distributed.

Table 5.6 lists the major companies in these two sectors. Almost all of these companies target OLED display industry as the key business, as the OLED lighting industry is so far miniscule in comparison. The equipment business is dominated by only a few companies, notably Canon Tokki of Japan and Sunic of Korea—both supply production-scale OLED thin-film deposition equipment of G6 and above. U.S. equipment makers include large companies such as AMAT, which provides large-area physical-vapor-deposition equipment for both OLED and the TFT backplanes, and small start-ups such as Kateeva, which provides large-area inkjet deposition equipment for RGB patterning and encapsulation. The material business is considerably more fractured compared to the equipment business, largely due to the need for a large number of different emitting and charge-transport materials comprising the multi-layers in the OLED stack. Material suppliers tend to limit their business to specific categories of materials. Idemitsu Kosan of Japan, for instance, is known as the major supplier for blue fluorescent materials, including both host and dopant molecules. To a large extent, their business is supported by their strong intellectual property (IP) position in the blue fluorescent emitter technology. Likewise, Universal Display Corp. (UDC), a U.S.-based company, has dominated the business of phosphorescent OLED materials due to their strongly held IP position in iridium-based emitters.

Current OLED-SSL products are manufactured using G2 vapor-deposition tools (capable of handling mother-glass size of 370 mm × 470 mm). Planned installation of G5 tools for OLED-SSL products (1,100 mm × 1,200 mm) was recently announced by LGD. Estimated capital cost, including clean rooms and support facilities, is \$75 million for a G2 tool, \$200 million for G5, and \$400 million for G8 (2,200 mm × 2,500 mm).⁶ To reduce capital cost, high-speed, roll-to-roll solutions or vapor-deposition processes are being developed for the manufacture of flexible OLED-SSL products. Konica Minolta and Sumitomo Chemical of Japan are leading such efforts with focus on solution-processed, polymer-based OLEDs by the latter. Unlike OLED display products, OLED-SSL products are more suited for roll-

to-roll manufacturing as they do not require high-density pixilation. Although it promises to significantly reduce cost, the roll-to-roll process has yet to be adopted as a production tool for flexible OLED-SSL products. Today's flexible commercial OLED products, including displays and SSL, are manufactured using a standard vapor-deposition process involving rigid plates.

Huge investments are being made in the OLED display industry to lower the cost of producing OLED displays, including developments in alternative substrates, lower-cost materials, large-area inline tools, reduced tact time, and robust thin-film encapsulation, all of which are transferrable to the development of OLED-SSL products. Rapid cost reduction in OLED-SSL manufacturing is to be expected with the maturity of the OLED display industry.

Both OLED-SSL and OLED-TV products are based on white tandem OLED technology and share similar manufacturing processes. OLED-SSL will directly benefit from the advances made in OLED-TV in terms of technology development and cost reduction.

Light extraction is an essential component in OLED-SSL that is not shared by OLEDs for displays. Internal light extraction is deemed to be important, but robust and low-cost methods for its implantation in OLED-SSL has not yet been developed.

FINDING: OLED-SSL manufacturing cost is high due to high cost of capital equipment and materials. The rapid growth of the OLED display industry should have a positive impact on the cost reduction of OLED-SSL products in the near future.

REFERENCES

- Black, T. 2015. GE splits lighting to form LED unit as \$5 billion in sales seen. *Bloomberg*. October 7. <https://www.bloomberg.com/news/articles/2015-10-07/ge-splits-lighting-to-form-led-unit-as-5-billion-in-sales-seen>.
- DOE (U.S. Department of Energy). 2015. *Solid-State Lighting R&D Plan*. Washington, D.C. May.
- DOE. 2016. *Solid-State Lighting R&D Plan*. Washington D.C. June.
- OSRAM. 2015. "Investments of About €3 Billion Create New Growth Prospects for Osram." Press release. November 11. https://www.osram.com/osram_com/press/press-releases/_business_financial_press/2015/investments-of-about-3-billion-create-new-growth-prospects-for-osram/index.jsp.
- Prodhon, G. 2015. Osram to separate from lamps and focus on automotive. *Reuters*. April 21. <http://www.reuters.com/article/us-osram-licht-divestiture-idUSKBN0NC1NG20150421>.
- Wang, L. 2016. Epistar announces plan to shut down Taoyuan production. *Taipei Times*. May 24. <http://www.taipeitimes.com/News/biz/archives/2016/05/24/2003646961>.

⁶ Ibid.

Appendixes

A

Committee Biographical Information

JOHN G. KASSAKIAN, *Chair*, is professor emeritus of electrical engineering and former director of the Laboratory for Electromagnetic and Electronic Systems at the Massachusetts Institute of Technology (MIT). His expertise is in the use of electronics for the control and conversion of electrical energy, industrial and utility applications of power electronics, electronic manufacturing technologies, and automotive electrical and electronic systems. Prior to joining MIT, he served in the U.S. Navy. Dr. Kassakian is on the boards of directors of a number of companies and has held numerous positions with the Institute of Electrical and Electronics Engineers (IEEE), including founding president of the IEEE Power Electronics Society. He is a member of the National Academy of Engineering (NAE), a life fellow of the IEEE, and a recipient of the IEEE's William E. Newell Award for Outstanding Achievements in Power Electronics (1987), the IEEE Centennial Medal (1984), and the IEEE Power Electronics Society's Distinguished Service Award (1998). He has served on a number of committees of the National Academies of Sciences, Engineering, and Medicine, including the Committee on Assessment of Solid-State Lighting, Phase One, the Committee on Overcoming Barriers to the Deployment of Plug-in Electric Vehicles, and the Committee on Light-Duty Vehicle Technologies to Improve Fuel Economy. He has an Sc.D. in electrical engineering from MIT.

EVELYN L. HU, *Vice Chair*, is the Tarr-Coyne Professor of Applied Physics and Electrical Engineering in the Harvard University School of Engineering and Applied Sciences. Prior to her appointment at Harvard, Dr. Hu was the scientific co-director of the California Nanosystems Institute, a University of California, Los Angeles–University of California, Santa Barbara (UCSB), collaborative California Institute for Science and Innovation. Her research focuses on high-resolution fabrication of compound semiconductor electronic and optoelectronic devices, candidate structures for the realization of quantum computation schemes, and novel device structures formed through the heterogeneous integration of

materials. Dr. Hu is a member of the American Academy of Arts and Sciences, the National Academy of Sciences (NAS), the NAE, and *Academica Sinica*. She is a recipient of the American Association for the Advancement of Science (AAAS) Lifetime Mentor Award and was named a National Science Foundation (NSF) Distinguished Teaching Scholar. She was named the 2005 UCSB Faculty Research Lecturer. She is a fellow of the IEEE, the American Physical Society (APS), and the AAAS, and holds an honorary doctorate of engineering from the University of Glasgow. From 1975 to 1981, Dr. Hu was a member of technical staff at Bell Laboratories in Holmdel, New Jersey. From 1981 to 1984, she served as a supervisor for VLSI (very-large-scale integration) patterning processes at Bell Laboratories in Murray Hill, New Jersey. In 1984, she joined UCSB as a professor of electrical and computer engineering. She received her B.A. in physics (*summa cum laude*) from Barnard College and her M.A. and Ph.D. in physics from Columbia University.

IAIN BLACK is senior director, Operations Matrix Platform, at Philips Lumileds. In this capacity he leads a team including several sub-con operations in Asia and a dedicated L2 factory in Penang, with the objective of building “up integrated” LED solutions in the illumination market. Previously, Mr. Black served as vice president, World Wide Manufacturing Engineering, Technology and Innovation, and focused on providing structure, vision, and direction for innovation, cost down, capacity expansion, dfx, and new product and technology introduction. He was general manager of the Lumileds San Jose plant from 2008 to 2010. Prior to his arrival at Lumileds, Mr. Black was for 8 years at Anadigics in Warren, New Jersey, where he was director of supply chain and a member of the senior management staff for wafer fabrication operations. From 1989 to 2000, he was with National Semiconductor UK where his duties focused on manufacturing lithography and etch fabrication. He holds a B.Sc. (honors) in electrical and electronic engineering from the University of Dundee.

NANCY CLANTON is founder and president of Clanton & Associates, a lighting design firm specializing in sustainable design. She is a fellow of the Illuminating Engineering Society of North America (IES, formerly the IESNA) and is a LEED-accredited professional. Ms. Clanton is a past member of the board of directors of the International Association of Lighting Designers (IALD) and the International Dark Sky Association (IDA) and serves as chairperson for the IES Outdoor Environmental Lighting Committee, the IES/IDA Model Lighting Ordinance Task Force, and the IES Mesopic Committee. Additionally, she serves as a member of the advisory committee of *Environmental Building News*, the professional advisory board for the Engineering Department at the University of Colorado, Boulder, and the U.S. Green Building Council. Ms. Clanton is a topic editor for the *IESNA Lighting Handbook* (9th edition), and her committee was responsible for the production of the IESNA Recommended Practices on Outdoor Lighting. She was group leader for the “Greening of the White House” initiative and received the 1999 Contribution to the Built Environment Award from the Colorado North Chapter of the American Institute of Architects (AIA). In 2001, Ms. Clanton served as a final editor for the *Advanced Lighting Guidelines* written by the California Energy Commission. She speaks throughout the nation on topics relating to sustainable design, energy efficiency, and light pollution. Her firm’s lighting design projects reflect her sustainable philosophy, and 10 of its projects have been named to the AIA Committee on the Environment Earth Day Top Ten List. Projects for which Clanton & Associates designed the lighting are LEED rated and several current projects are registered, certification pending. She obtained her B.S. in architectural engineering, illumination emphasis, from the University of Colorado, Boulder, and she is a registered professional engineer in the states of Colorado and Oregon.

WENDY DAVIS is an associate professor in lighting, the director of illumination design, and the associate dean (education) in the faculty of Architecture, Design and Planning at the University of Sydney. Prior to this appointment, she spent 7 years as a vision scientist in the Lighting and Color Group at the National Institute of Standards and Technology (NIST) in the United States. Dr. Davis’s research focuses on lighting and color, with a particular interest in novel illumination applications of emerging and next-generation energy efficient lighting technologies. She is a member of the IES Color Committee, was the chair of the CIE (International Commission on Illumination, the Commission Internationale d’Eclerage) technical committee 1-69, “Colour Rendition by White Light Sources,” and was a member of the National Academies’ Committee on Assessment of Advanced Solid-State Lighting. With a colleague at NIST, she developed the color quality scale (CQS) to evaluate the color rendering properties of light sources for general illumination, leading to a 2009 U.S. Department of Commerce Silver Medal Award

for Scientific/Engineering Achievement for developing measurement methods and technical standards to accelerate the commercialization of energy efficient, solid-state lighting products. Dr. Davis earned her Ph.D. (2004) and M.S. (2001) degrees from the University of California, Berkeley, in vision science after completing her B.A. (1999) in psychology and physiology at the University of Minnesota.

MICHAEL ETTEMBERG is currently working with New York University (NYU) as a presidential fellow to help improve the educational process and create new opportunities for commercialization of NYU’s technologies. He retired from Sarnoff Corporation (formerly RCA Laboratories) after 35 years, ending as senior vice president in charge of all of Sarnoff’s device research, including a small silicon integrated circuit fabrication, TV displays, optoelectronics, and cameras. Dr. Ettenberg was elected to membership in the NAE for his work on optoelectronic components, including the evolution of practical and reliable semiconductor lasers. He also has extensive experience with III-V materials and optoelectronic devices. He developed the dielectric mirrors used on all of today’s laser diodes. Dr. Ettenberg has published 110 papers and has been awarded 35 patents, mainly in the area of optoelectronics. He also was president of the IEEE Lasers and Electro-Optics Society and was a member of the Defense Science Board. He received his B.S. from the Polytechnic Institute of Brooklyn and his M.S. and Ph.D. from NYU.

PEKKA HAKKARAINEN is vice president of government and industry relations at Lutron Electronics. He has held several technical, market development, and business development positions since joining Lutron in 1990. Dr. Hakkarainen has been involved in National Electrical Manufacturers Association (NEMA) activities since the mid-1990s, and he is the immediate past chair of the Lighting Systems Division. He currently chairs the High Performance Building Council as well as the Daylight Management Council. Dr. Hakkarainen has also served on the board of the Global Lighting Association and is the current chair of the General Assembly of the Connected Lighting Alliance. He is also a voting member of the ASHRAE 90.1 Committee and a member of the IES. Dr. Hakkarainen has served on two committees for the National Academies charged with evaluating public spending on solid-state lighting. He received B.A. and M.A. degrees in mathematics from Cambridge University, England, and a Ph.D. in plasma physics from MIT. He holds seven U.S. patents.

NADARAJAH NARENDRAN is director of research at the Lighting Research Center (LRC) and professor in the School of Architecture at Rensselaer Polytechnic Institute. He spearheads LRC’s Solid-State Lighting program with concentrated research efforts in the areas of light-emitting diode (LED) lighting performance, packaging, and appli-

cation. Dr. Narendran is a fellow member of the IES and organizes the Alliance for Solid-State Illumination Systems and Technologies. He has been awarded the Taylor Technical Talent Award for Best Technical Paper from the IES and the Pew Teaching Leadership Award. Dr. Narendran received a B.S. in physics from the University of Peradeniya, Sri Lanka, and a Ph.D. and M.S. in physics from the University of Rhode Island.

MAXINE SAVITZ is a retired general manager of technology partnerships at Honeywell, Inc. Dr. Savitz was vice president of the NAE from 2006 to 2014. She has managed large research and development (R&D) programs in the federal government and the private sector. Some of her positions include the following: chief, Buildings Conservation Policy Research, Federal Energy Administration; professional manager, Research Applied to National Needs, NSF; division director, Buildings and Industrial Conservation, Energy Research and Development Administration; deputy assistant secretary for conservation, U.S. Department of Energy; president, Lighting Research Institute; and general manager, Ceramic Components, AlliedSignal, Inc. (now Honeywell). Dr. Savitz has extensive technical experience in materials, fuel cells, batteries and other storage devices, energy efficiency, and R&D management. She is a member of the NAE, a fellow of the American Academy of Arts and Science, and has been, or is serving as, a member of numerous public- and private-sector boards and has served on many energy-related and other National Academies committees. She has a Ph.D. in organic chemistry from MIT.

MICHAEL G. SPENCER is professor of electrical engineering at the Cornell University. His research interests are in the epitaxial and bulk growth of compound semiconductors, such as GaAs, SiC, and AlN (growth techniques include molecular beam epitaxy, vapor phase epitaxy, liquid phase epitaxy, and sublimation); microwave devices; solar cells; and electronic materials characterization techniques (including deep level transient spectroscopy and photoluminescence). His particular interest has been in the correlation of device performance with material growth and processing parameters. Dr.

Spencer's work has emphasized wide bandgap materials, and his group was the first to produce conducting AlN and thick films of beta SiC grown by the bulk sublimation technique. More recently, he has been involved with two-dimensional materials graphene and boron nitride. He is a recipient of the Presidential Young Investigator Award for 1985, the Alan Berman Research Publication Award from the Naval Research Laboratories in 1986 (for research leading to the first identification of a self interstitial defect in AlGaAs), the White House Initiative Faculty Award for Excellence in 1988, a Distinguished Visiting Scientist appointment at Jet Propulsion Laboratories in 1989, and a 1992 recipient of a NASA Certificate of Recognition. He is on the permanent committee for the Electronic Materials Conference and the Compound Semiconductor Conference, and he helped initiate and form the International Conference on Silicon Carbide and Related Materials.

CHING TANG is professor of chemical engineering at the University of Rochester. His research interests lie in the general areas of chemical and condensed matter physics and, in particular, organic electronics. Dr. Tang has been recognized for the invention of the high-efficiency organic light-emitting diodes (OLEDs). Based on this key invention, a superior flat-panel display technology has been developed for electronics display applications from cellular phones to large-area high-definition television screens. He has also been recognized for the discovery of the organic hetero-junction diode. This discovery has been recognized as a milestone contribution to the field of organic electronics and opto-electronics. The hetero-junction device structure has been found to be the key to obtaining high performance in organic-based, thin-film devices, including OLEDs and solar cells. Dr. Tang's recent research projects include the following: applications of organic electronic devices, OLEDs, solar cells, photoconductors, image sensors, and photoreceptors; basic studies of organic thin-film devices (charge injection, transport, recombination and luminescence properties) and metal-organic and organic-organic junction phenomena; and development of flat-panel display technology based on OLEDs. He has a Ph.D. from Cornell University.

B

Committee Meetings and Presentations

NOVEMBER 11-12, 2015, WASHINGTON, D.C.

Briefing on DOE Solid-State Lighting Program
Jim Brodrick, Lighting Program Manager,
U.S. Department of Energy (DOE)

LED and Control Compatibility
Ethan Biery, LED Engineering Leader, Lutron

Lighting and LEDs Market Overview and Forecast
Stephanie Pruitt, Senior Analyst, Strategies Unlimited

NAS Issues for Committee Input
Jim Brodrick, Lighting Program Manager, DOE

JANUARY 5-6, 2016, WASHINGTON, D.C.

ENERGY STAR Certification and Market Share Lighting
Products
Kathleen Vokes, Environmental Protection Agency
(EPA)

ENERGY STAR Lighting: Overview of Lighting
Specifications
Daniel Rogers, ICF International, on behalf of EPA

LED and OLED SSL Manufacturing Value Chain and
Related DOE SSL Program R&D
P. Morgan Pattison, President, SSLS, Inc., and Senior
Technical Advisor, DOE Solid-State Lighting Program

Future Directions in Solid-State Lighting: Next Generation
LEDs and Laser Lighting
Steven DenBaars, University of California and Soraa
Inc.

FEBRUARY 22-24, 2016, IRVINE, CALIFORNIA

Solid-State Lighting: The Interaction Between Incentives
and Standards
Mary Anderson, Pacific Gas and Electric Company

Bringing OLED Lighting to Market
Michael Boroson, OLEDWorks

Desirable Future of Lighting
Jim Brodrick, DOE

NAS Symposium on Solid-State Lighting
Ken Rider, California Energy Commission

Assessment of Solid-State Lighting—Industry Experience
Ralph C. Tuttle, CREE

Untitled Presentation
Sebastian Suh, Manager, OLED Light, LG Display

Ecology, Physiology, Human Health, and Light
George C. Brainard and John P. Hanifin,
Thomas Jefferson University Light Research Program

Plenary Presentation: National Academy of Sciences
Symposium
Jed Dorsheimer, CANACCORD Genuity

Effects of Light on Human Health and Wellbeing:
Research and Applications
Mariana G. Figueiro, Lighting Research Center,
Rensselaer Polytechnic Institute

Input for NAS Symposium on LED Lighting
Noah Horowitz, Center for Energy Efficiency
Standards, Natural Resources Defense Council

Emerging Lighting Applications

Robert F. Karlicek, ERC Director, Lighting Enabled Systems and Applications, and Rensselaer Polytechnic Institute

Ecology, Physiology, and Solid-State Lighting

Travis Longcore, University of Southern California

LED Lighting for Plant Applications

Neil Mattson, Cornell University

LED Lighting as a Platform for Indoor Positioning for Mobile Devices

Marc Saes, Acuity Brands, eldoLED, and Aleksandar Jovicic, Qualcomm, Inc.

Color Metrics: Where Are We? Where Are We Going To?

Yoshi Ohno, National Institute of Standards and Technology

OLED Lighting Discussion

Yuan-Sheng Tyan

APRIL 14-15, 2016, WASHINGTON, D.C.

Xicato Overview Presentation

Willem Sillevs Smitt, Xicato, Inc.

OSRAM Americas Company Presentation

John Tremblay, OSRAM Americas

C

Nomenclature and Definitions

LIGHTING EQUIPMENT

Lighting designers and engineers use different terms for lighting equipment than are used in the vernacular. In this report, we will be using the engineering terms. A *luminaire* is the combination of light fixture hardware, a ballast or driver if applicable, and a light source, commonly called a *lamp* (i.e., a light bulb). Thus, the term lamp can refer to an incandescent bulb, a compact fluorescent light (CFL) bulb, or a light-emitting diode (LED) replacement “bulb.” This report will use the term lamp. A *luminaire* consists of, minimally, an integrated light source or lamp holder, commonly called a socket, and the way to connect to the electrical supply. Most fixtures also contain optical elements that distribute the light as desired, such as a reflector, lens, shade, or globe. When needed, fixtures and luminaires contain a ballast or a driver. A *ballast* is an electronic device that converts incoming electricity to the proper voltage and current required to start and maintain the operation of a lamp. The term driver refers to the corresponding device used in an SSL luminaire. Luminaire examples include chandeliers, downlights, table lamps, wall sconces, recessed or pendant mounted luminaires, and exterior streetlights. When equipped with lamps, they are called luminaires. The types of lamps typically encountered are discussed below in the section, “Lamps.”

METRICS FOR MEASURING LIGHT OUTPUT

The portion of the electromagnetic spectrum that can be perceived by the human visual system is called the *visible spectrum*. The amount of light, weighted by the sensitivity of the visual system, emitted by a source per unit time is its *luminous flux* (Figure C.1) and is measured in *lumens* (lm). This makes lumens one of the appropriate pieces of information for lamp packaging to help consumers choose the appropriate replacement lamps. Lumens provide a description most closely related to brightness and should be referred to when choosing replacement lamps. A proliferation of fact

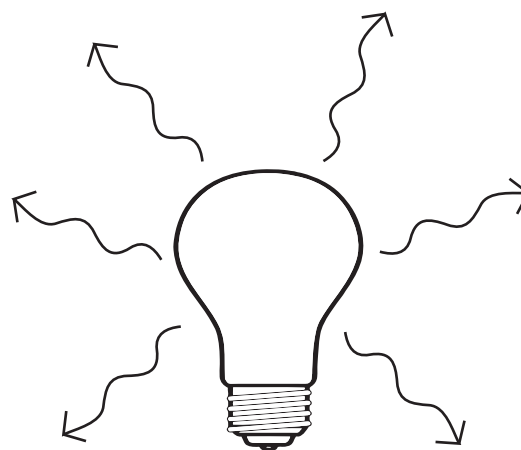

LUMINOUS FLUX (lumens)

FIGURE C.1 Luminous flux.

sheets and labels has accompanied the recent introduction of new lighting technologies, leaving some consumers confused about the relationship between watts (W) and lumens. That relationship is determined by the energy efficiency of the product. Watts describe the amount of electrical power consumed by the product, and lumens describe the rate at which it emits light. For example, most 60 W incandescent lamps emit approximately 850 lumens. Similarly, many 13 W CFLs emit 850 lumens.

Luminous intensity (Figure C.2) is the luminous flux per unit solid angle, evaluated in terms of a standardized visual response and expressed in candela. The magnitude of luminous intensity results from luminous flux being redirected

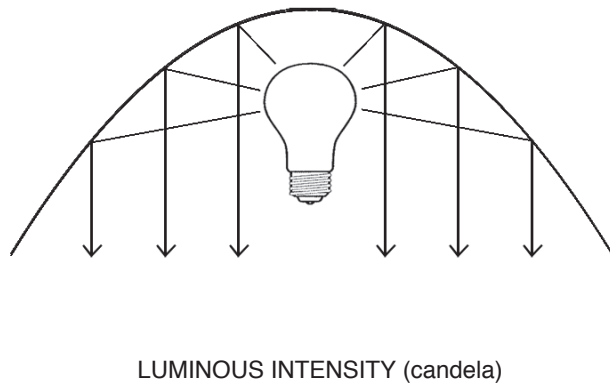

FIGURE C.2 Luminous intensity.

by a reflector or magnified by a lens.¹ This measurement is used primarily to describe the specific light intensity and distribution of a luminaire. *Illuminance* is the concentration of luminous flux incident on a surface (Figure C.3). The unit of illuminance is lux (lx), and it indicates the number of lumens per square meter. Lumens per square foot are called footcandles (fc). Whereas luminous flux relates to the total output of a lamp or lighting product, illuminance relates to the amount of light striking a surface or point. Illuminance depends on the luminous flux of the light sources and their distances from the illuminated surface.

Luminance is a measure used for self-luminous or reflective surfaces (Figure C.4). It expresses the amount of light, weighted by the sensitivity of the visual system, per unit area of the surface that is traveling in a given direction and is expressed as *candelas per square meter* (cd/m^2). When referring to illuminated surfaces, luminance is determined by the incident light (illuminance) and the reflectance characteristics of the surface. For instance, light and dark colored walls will have different luminance values when they have the same illuminance. Luminance is a metric used for internally illuminated variable-sized flat light sources forms, such as sheets or tapes (Figure C.4), since the total luminous flux will depend on the surface area of the product.

The *luminous efficacy* of a lighting product is the ratio of the luminous flux to the total electrical power consumed and has units of lumens per watt (lm/W). A perfect light source—that is, one that converts all the electricity into visible light—would have an efficacy of $408 \text{ lm}/\text{W}$ for an assumed color rendering index (CRI; a measure of color quality, discussed below) of 90 (Phillips et al., 2007).² The luminous efficacy of a traditional 60 W incandescent lamp (luminous flux of 850 lumens) is such that only 14.2 lumens

¹ The concept of solid angle has a strict geometric definition but can be thought of as a way to describe the focusing and redirecting of a light source by the lenses and reflectors in the luminaire.

² A different choice of CRI = 80 would lead to a maximum efficacy of $423 \text{ lm}/\text{W}$, and so forth.

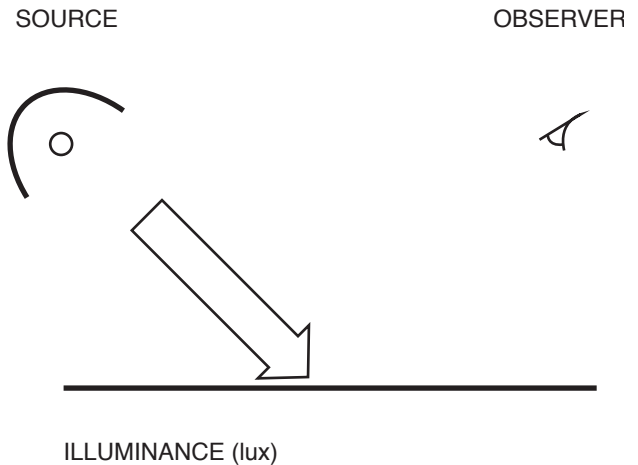

FIGURE C.3 Illuminance. The amount of light striking a surface or point, measured in lux (lx).

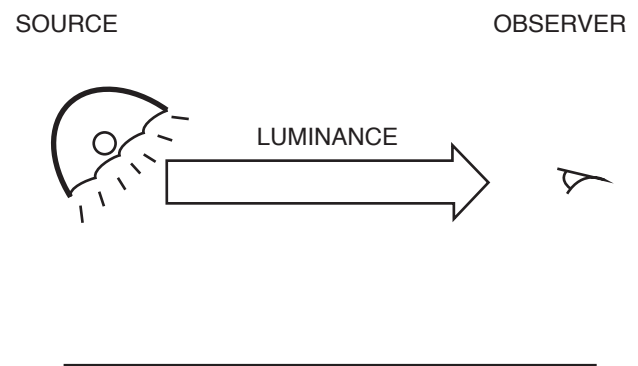

FIGURE C.4 Luminance of a luminaire.

are emitted per watt of power drawn by the light bulb. As efficacies increase, more of the power is used to generate visible light, and this leads to a more efficient product. High color quality LEDs currently are being manufactured with efficacies in the range of 60 to $188 \text{ lm}/\text{W}$.

It is important to note that efficacy is different from efficiency. The efficiency of a lighting system is the ratio between the obtained efficacy and the theoretical maximum efficacy of a light source ($408 \text{ lm}/\text{W}$ for a CRI of 90) and is always expressed as a percentage. Thus, it accounts for the ballast efficiency (if there is one), the light source efficacy, and the luminaire efficiency (see Figure C.5) in one lumped parameter. Thus, incandescent lamps with system efficacies ranging from 4 to $18 \text{ lm}/\text{W}$ (depending largely on the wattage of the bulb) will have system efficiencies of only about 0.2 to 2.6 percent. Efficiency does not, however, account for the perceived quality of the light. Using the theoretical maximum of $408 \text{ lm}/\text{W}$ and the ranges of efficacies for different lighting technologies leads to the ranges of system efficiencies shown in Figures C.5 and C.6.

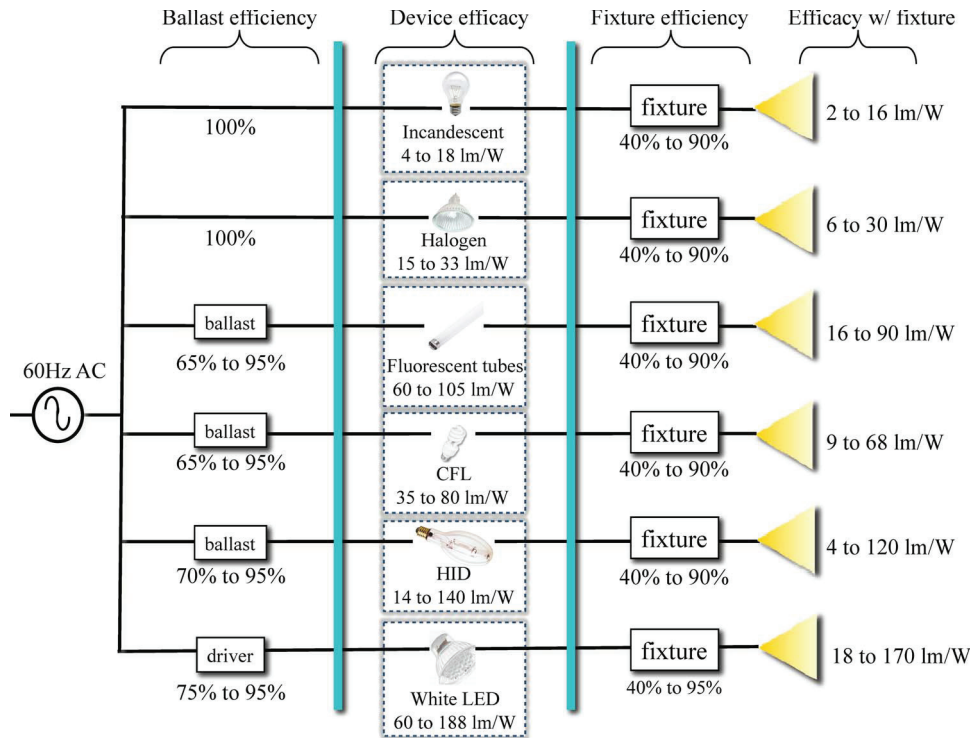

FIGURE C.5 Efficacy of lamps and luminaires. Values in the left-most column report the range of efficiencies for ballasts and electronic drivers. Values in the central column report efficacies for different lighting devices. The values on the third column report ranges of luminaire efficiencies. The values on the right-most column report the overall system efficacies of the luminaire. Figure adapted from Azevedo et al. (2009), where the efficacies for white LEDs were updated to reflect currently commercialized warm and cool white LEDs. © 2009 IEEE. Reprinted, with permission, from I.L. Azevedo, M.G. Morgan, and F. Morgan, 2009, The transition to solid state lighting. *Proceedings of the IEEE* 97:481-510.

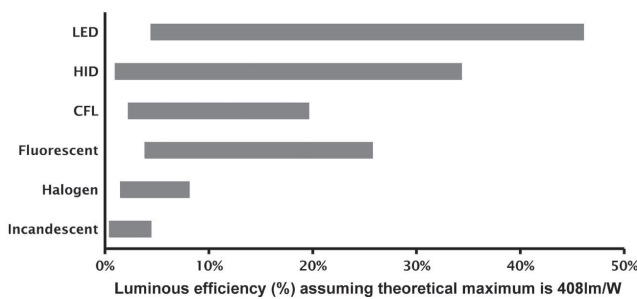

FIGURE C.6 Overall efficiencies of lighting systems (lower bounds) and devices (upper bounds) when assuming that the theoretical maximum lamp efficacy is 408 lm/W. NOTE: CFL = compact fluorescent lamp; HID = high-intensity discharge lamp; LED = light-emitting diode. Lower and upper bounds correspond to the low and high efficacy values shown in Figure C.5. © 2009 IEEE. Reprinted, with permission, from I.L. Azevedo, M.G. Morgan, and F. Morgan, 2009, The transition to solid state lighting. *Proceedings of the IEEE* 97:481-510.

VISIBLE SPECTRUM AND QUALITY OF LIGHT

The human eye can generally detect light with wavelengths between 380 nm (corresponding to blue/violet light) and 780 nm (corresponding to red light). The *spectral power distribution* (SPD) determines several important properties of a light source. The SPD describes the relative amount of light per wavelength emitted by a light source and is often graphically represented, as shown in Figure C.7. This figure shows the SPDs of a halogen lamp, an RGB LED (which produces white light by combining red, green, and blue component LEDs), an OLED, and a combination of four colored lasers.

The color of emitted light as perceived by people, called chromaticity, is regulated by the spectral composition. The human visual system does not process light on a wavelength-by-wavelength basis. Instead, the brain receives signals from only three input channels, the different cone photopigments found in the eye. Because of this, countless different SPDs can produce light identical in chromaticity. To illustrate this,

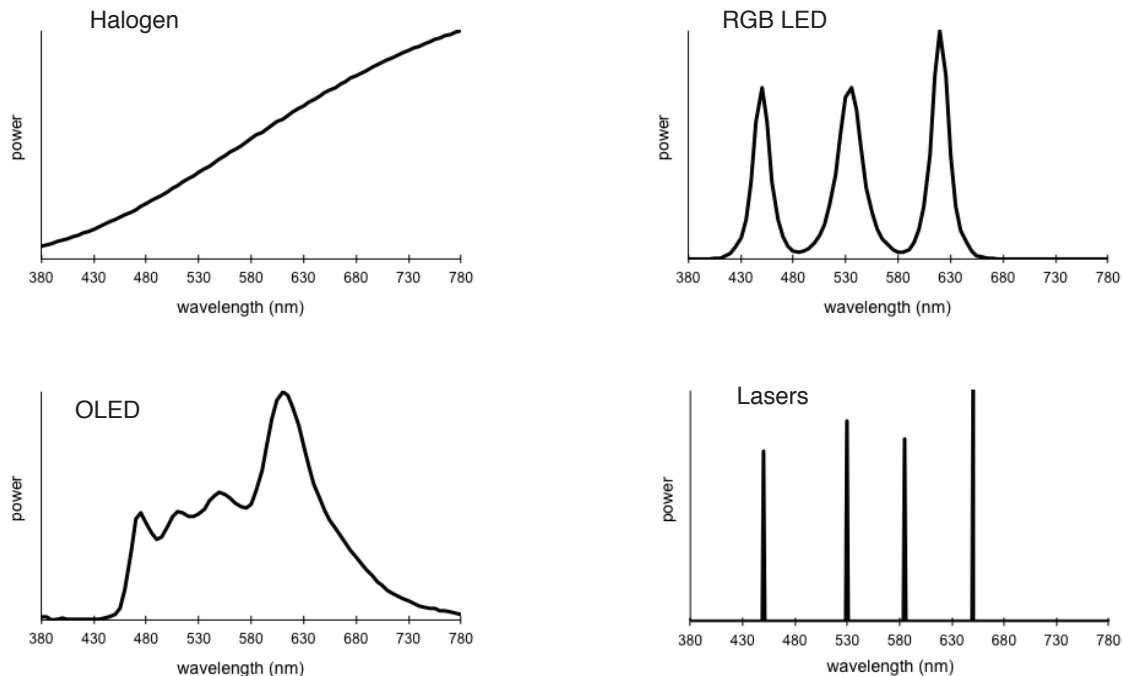

FIGURE C.7 Spectral power distribution from very different light sources that were chosen to produce identically appearing white light. The red, green, blue (RGB) light-emitting diode (LED) produces white light by combining red, green, and blue component LEDs, as does a combination of four colored lasers.

the four widely varying SPDs shown in Figure C.7 would all produce light that would appear indistinguishable.

On the *correlated color temperature* (CCT) scale, all four spectra in Figure C.7 are approximately 3,000 K. CCT is used to describe nominally white light sources and refers to the temperature of a blackbody radiator that produces a light perceived to be most similar in chromaticity to the white light source. A typical incandescent lamp has a CCT of 2,500 to 3,000 K, whereas office and school lighting is often 4,000 to 5,000 K. Lower CCTs include more light nearer the red end of the visible spectrum and are perceived to be “warmer,” while higher CCTs tend toward the blue end and are perceived to be “cool.” In somewhat of a misnomer, the labeling is indicative of the feelings they evoke rather than their actual temperatures. Though the color of daylight changes throughout the day and with location on Earth, it is commonly described as having a CCT of 6,500 K. Though CCT is widely used among lighting manufacturers and designers, it only describes one dimension of light source chromaticity, in the blue-yellow direction. It does not consider pink-green shifts in white light color, though Duv is a measure increasingly used for that information.

The most common system for specifying and communicating the precise chromaticity of light sources uses CIE 1931 (x, y) chromaticity coordinates (CIE, 2004). The CIE 1931 (x, y) chromaticity diagram is shown in Figure C.8. The curved edge of the outer horseshoe shape on the diagram is

the *spectrum locus* and consists of the colors of monochromatic (only one wavelength) radiation. The straight edge line is the *purple line*, and the colors are always a combination of red and blue (not monochromatic).

Chromaticity does not provide all of the color information of interest for general illumination applications. The color of the light itself does not predict the appearance of colored objects illuminated by the source, a property referred to as color rendering. Though color rendering is determined by the spectral output of a light source, it cannot be predicted by a cursory inspection of the shape of the spectral power distribution and subtle differences in SPD can produce marked differences in the chromaticity of illuminated objects (Ohno, 2005). The SPD also determines the LER (i.e., the luminous efficacy of radiation) of a light source. In technical terms, LER is the ratio of luminous flux to radiant flux.³ In simple terms, the LER is luminous efficacy that could be achieved if the light source was able to convert electricity to light perfectly, with no losses. The final luminous efficacy of a light source is determined from both the LER and the efficiency with which the technology converts electricity to light. The sensitivity of the human visual system differs for the various wavelengths in the visible range. The relationship between wavelength and the relative sensitivity of the

³ Radiant flux is the amount of electromagnetic energy emitted per unit time at all wavelengths including visible light and other spectral bands. As such it will exceed the luminous flux.

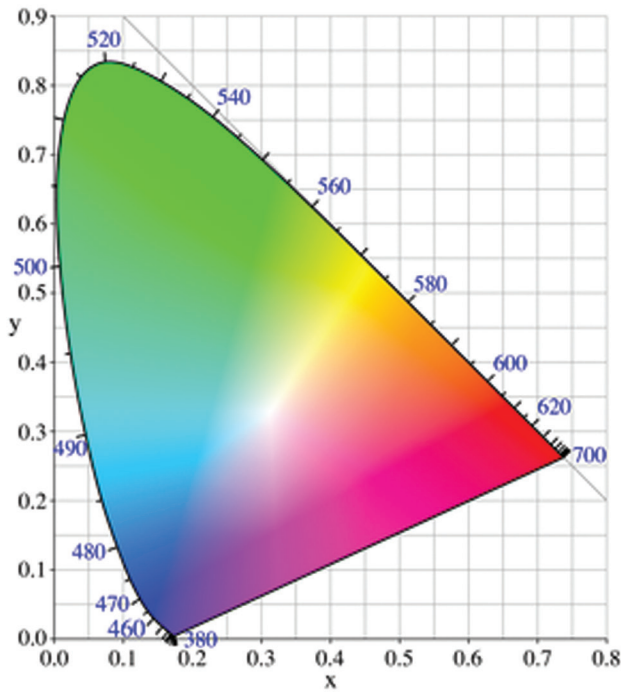

FIGURE C.8 1.10 CIE 1931 (x,y) chromaticity diagram. Numbers indicate wavelength of light, in nanometers. SOURCE: Wikipedia Commons.

human visual system is described by the Spectral Luminous Efficiency Function (V_λ) (CIE, 1926), which is shown by the dashed curves in Figure C.9. This function peaks at 555 nm. Light of this wavelength has a LER of 683 lm/W, setting the upper bound for luminous efficacy, as illustrated by the 555 nm laser in panel *a*. It is important to note that white light cannot achieve 683 lm/W, only light at 555 nm can. Visual sensitivity is markedly lower for light in the short and long wavelength regions of the visible spectrum. The other three panels of Figure C.9 show different SPDs and their corresponding LER. Panel *b* shows an RGB white LED, panel *c* shows a different type of white LED (called a phosphor LED), and panel *d* shows the SPD of a typical incandescent lamp. As shown, the effect of spectral power distribution on luminous efficacy can be substantial. The incandescent SPD has a relatively low LER because it has a lot of energy in the very long visible and infrared wavelengths, to which the visual system is either minimally or completely insensitive.

Though the wavelengths of light to which the eye is most sensitive lie in the middle of the spectrum, a light source composed of light only in the middle of the visible spectrum would not be useful for general illumination. To achieve desirable color characteristics, light of other wavelengths must be present. There is generally a trade-off between luminous efficacy and color quality (Ohno, 2005). Depend-

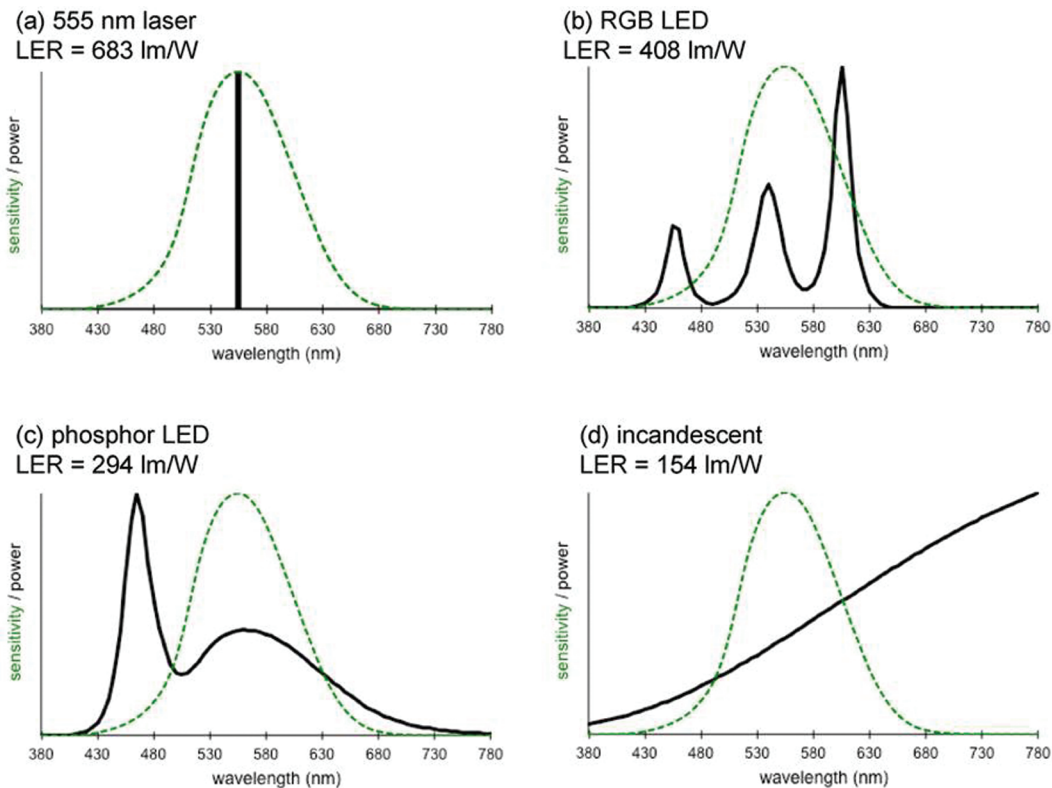

FIGURE C.9 Spectral power distribution determines luminous efficacy of radiation (LER). The dashed green curves show the Spectral Luminous Efficiency Function, and the black curves are light source’s spectral power distributions. NOTE: RGB = red, green, blue.

ing on the application and goals of a lighting product or lit environment, a luminaire manufacturer or lighting designer may choose to prioritize one trait over the other. For example, in a parking garage with lights on 24 hours a day, a specifier may require excellent efficacy and accept subpar color quality. On the other hand, a museum may require superior color and be willing to sacrifice efficacy.

Good color rendering can be achieved with such discontinuous light spectra because of the properties of the other two elements in the process of perceiving object colors: the reflectance of the objects and the absorption of the cone photopigments in the human visual system. All objects, natural or man-made, reflect as a function of wavelength in a very broad and continuous manner. The reflectance factors of these objects (the proportion of light reflected as a function of wavelength) do not show sudden spikes or isolated dips in reflectivity across the visible spectrum. Because of this, the general shape of the reflectance factor can be interpolated with fairly coarse wavelength sampling. The three cone photopigments responsible for color vision have absorption functions that are very broad, continuous, and overlapping in wavelength sensitivity. Each cone type responds to many wavelengths, though sensitivity is different depending on the wavelength. The outputs of these photoreceptors do not signal the wavelength composition of the stimulus to the brain. For instance, a certain level of activity from one cone type could result from a small amount of energy at every wavelength it is sensitive to or a lot of energy at only one wavelength it is sensitive to. The visual system makes absolutely no distinction between these two situations (Ruston, 1972). The perception of color arises from combining and comparing the activity among the three cone types. Therefore, countless combinations of input wavelengths can lead to the exact same perception of color. These circumstances, in which objects reflect in a fairly predictable manner and the visual system interprets incoming light in terms of three broadly sensitive channels, allow a great deal of flexibility for the spectral content of light sources. A recent study demonstrated an extreme case of this in which light sources were developed composed of only four lasers (i.e., sources with extremely narrow emission spectra) with high color rendering quality (Neumann et al., 2011).

A light source need not emit energy at every visible wavelength in order to achieve high color quality (Figure C.9). An understanding of the spectral power distribution's effects on luminous efficacy and the color properties of a light source will enable SSL developers to optimize energy efficiency while maintaining good color quality.

LAMPS

There are many different kinds of lamps. Most of the lamps used in residential applications are *omnidirectional* (emit light in all directions) *incandescent lamps*, typically with a medium screw base (Figure C.10) that fits into most

residential luminaires. In addition, there are candelabra and intermediate base lamps that are commonly used in residential applications, especially in chandeliers and wall sconces. Incandescent lamps produce light by heating a tungsten filament to a temperature of approximately 2,500 to 3,000 K where the filament glows or *incandescences*.

Halogen lamps are incandescent lamps in which the tungsten filament has been enclosed in a capsule containing a halogen gas, typically bromine, which allows the filament to operate at a slightly higher temperature without reducing the rated life and resulting in a somewhat higher light output than the standard incandescent lamp. Halogen lamps are available that emit light omnidirectionally, as well as *directional varieties*, often known as *reflector lamps*. Reflector lamps are designated by the properties of their reflectors, such as *PAR* (parabolic aluminized reflector (Figure C.11), or *MR* (multifaceted mirror reflector), and are most commonly either standard incandescent or halogen. The low voltage *MR-16 lamp* (Figure C.12) commonly used in accent, task, and display lighting uses halogen technology.

Fluorescent lamps are available in a range of shapes and sizes. *Linear fluorescent lamps* are frequently used in commercial spaces (offices, stores) and are typically 4-foot-long

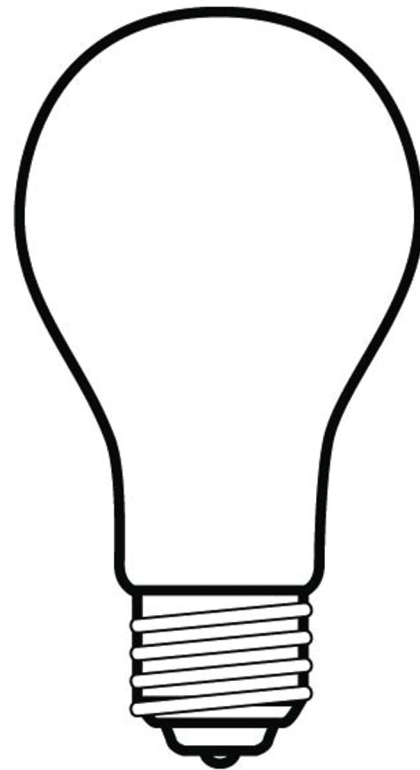

FIGURE C.10 Incandescent with medium screw base (A-19).

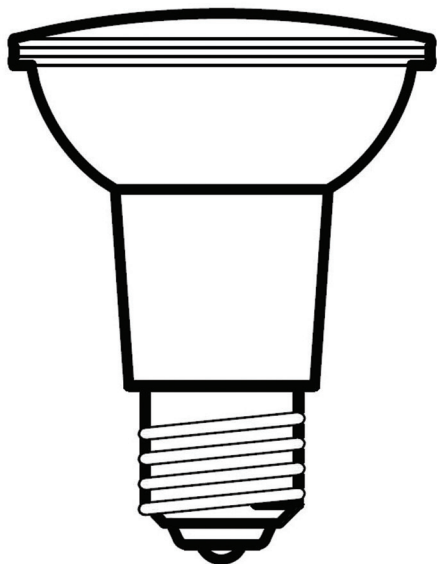

FIGURE C.11 PAR 20 lamp (tungsten halogen).

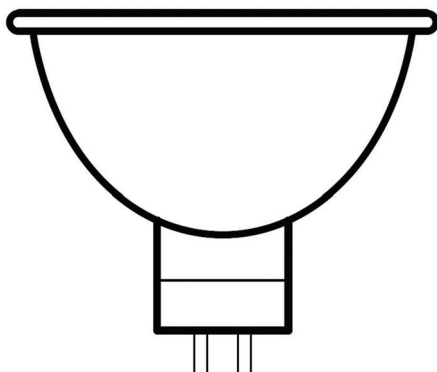

FIGURE C.12 MR16 lamp (tungsten halogen).

tubes. They are often installed in recessed luminaires in the ceiling or are pendant mounted from the ceiling. All fluorescent lamps require a ballast. *Compact fluorescent lamps* (CFLs) are available with screw bases and an integral ballast (Figure C.13) for use as replacements for incandescent lamps or with pin bases for use with a separate ballast (Figure C.14). Both CFLs and linear fluorescent lamps produce light by exciting phosphors, which then *fluoresce*, with ultraviolet energy. A small amount of mercury is added to the lamp to emit UV radiation at a suitable wavelength for exciting the phosphor.

High-intensity discharge (HID) lamps are electric lamps with tubes filled with gas and metal salts. The gas initiates an arc, which evaporates the metal salts, forming a plasma. This results in an efficient and high-intensity light source. These lamps are suitable for both indoor and outdoor applications and are generally used to light large spaces or roadways. All

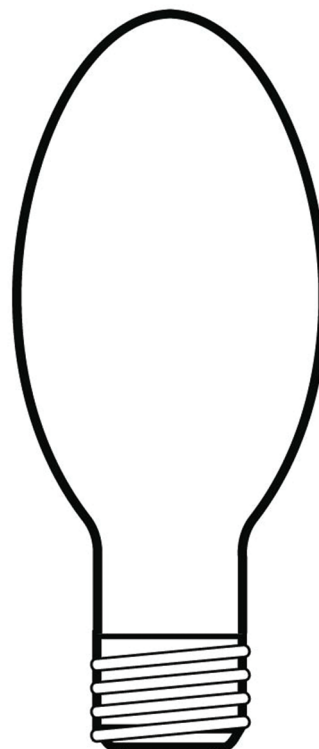

FIGURE C.13 Metal halide lamp (an example of high-intensity discharge lamp).



FIGURE C.14 Compact fluorescent lamp (screw base with integral ballast).

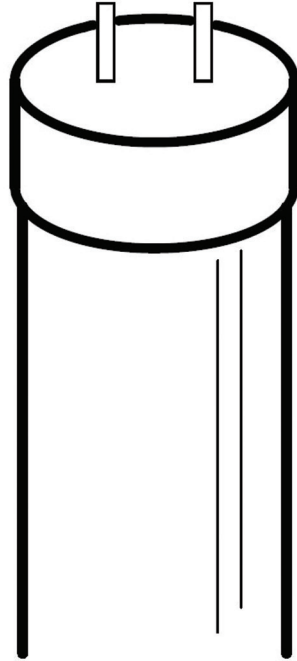

FIGURE C.15 Fluorescent lamp (T5) without integral ballast.

HID lamps require a ballast. *Mercury vapor*, *metal halide* (Figure C.15), and *high-pressure sodium lamps* are examples of specific types of HID lamps. HID lamps require a warm-up period to reach stable output as well as a cool-down period before restarting.

REFERENCES

- Azevedo, I.L., M.G. Morgan, and F. Morgan. 2009. The transition to solid-state lighting. *Proceedings of the IEEE* 97:481-510.
- CIE (Commission Internationale de l'Eclairage). 1926. *Commission Internationale De L'Eclairage Proceedings, 1924*. Cambridge, U.K.: Cambridge University Press.
- CIE. 2004. *Colorimetry*. Third edition. Technical Report. Vienna, Austria: CIE Central Bureau.
- Neumann, A., J.J. Wierer, W. Davis, Y. Ohno, S.R.J. Brueck, and J.Y. Tsao. 2011. Four-color laser white illuminant demonstrating high color-rendering quality. *Optics Express* 19(14):A982-A990.
- Ohno, Y. 2005. Spectral design considerations for white led color rendering. *Optical Engineering* 44(11).
- Phillips, J.M., M.E. Coltrin, M.H. Crawford, A.J. Fischer, M.R. Krames, R. Mueller-Mach, G.O. Mueller, et al. 2007. Research challenges to ultra-efficient inorganic solid-state lighting. *Laser and Photonics Reviews* 1(4):307-333.

D

Acronyms and Abbreviations

ANSI	American National Standards Institute	EISA	Energy Independence and Security Act
ARPA-E	Advanced Research Projects Agency-Energy	EML	light emissive layer
ARRA	American Recovery and Reinvestment Act	EPA	Environmental Protection Agency
ASHRAE	American Society of Heating, Refrigerating, and Air-conditioning Engineers	EPACT	Energy Policy Act
		EPCA	Energy Policy and Conservation Act
BES	basic energy sciences	EQE	external quantum efficiency
BTP	Building Technologies Program	ERDA	Energy Research and Development Administration
Btu	British thermal unit	ETL	electron transport layer
BULB Act	Better Use of Light Bulbs Act		
		fc	foot-candle
CB ECS	Commercial Buildings Energy Consumption Survey	FTC	Federal Trade Commission
CCT	correlated color temperature	GAO	Government Accountability Office
cd	candela	GSA	General Services Administration
CFL	compact fluorescent light		
CIE	International Commission on Illumination (Commission Internationale d’Eclerage)	HID	high-intensity discharge
CISPR	Special International Committee on Radio Interference (Comité International Spécial des Perturbations Radioélectriques)	HIL	hole injection layer
		HP	high power
CLTC	California Lighting Technology Center	HTL	hole transport layer
CNT	carbon nanotube	HVPE	hydride vapor phase epitaxy
COB	chip on board		
CRI	color rendering index	IALD	International Association of Lighting Designers
		ICC	International Code Council
DALI	Digital Addressable Lighting Interface	IDA	International Dark-Sky Association
DLA	Defense Logistics Agency	IEC	International Electrotechnical Commission
DLC	Design Lights™ Consortium	IECC	International Energy Conservation Code
DOD	Department of Defense	IES	Illuminating Engineering Society of North America
DOE	Department of Energy	IoT	Internet of Things
DSM	demand side management	IQE	internal quantum efficiency
DTV	digital television	ISS	International Space Station
		IT	information technology
EBL	exciton blocking layer	ITO	indium tin oxide
EERE	Office of Energy Efficiency and Renewable Energy		
EIA	Energy Information Administration	L Prize	Bright Tomorrow Lighting Prize
		LBNL	Lawrence Berkeley National Laboratory

LED	light-emitting diode	PF	power factor
LER	luminous efficacy of radiation	PFS	potassium fluorosilicate
LES	light-emitting surface	PG&E	Pacific Gas & Electric Company
LFL	linear fluorescent lamp	PHOLED	phosphorescent organic light-emitting diode
LIPA	Long Island Power Authority	PNNL	Pacific Northwest National Laboratory
lm	lumen		
LP	low power	QD	quantum dot
LPD	lighting power density		
LRC	Lighting Research Center	R&D	research and development
LUMEN	Lighting Understanding for a More Efficient Nation	RD&D	research, development, and demonstration
lx	lux	RECS	Residential Energy Consumption Survey
		RGB	red, green, and blue
MCPCB	metal-core printed circuit board	RGBY	red, green, blue, and yellow
MECS	Manufacturing Energy Consumption Survey	RoHS	restriction of hazardous substances
MOCVD	metal-organic chemical vapor deposition		
MP	mid-power	SBIR	Small Business Innovation Research
MQW	multiple quantum well	SCHER	Scientific Committee on Health and Environmental Risks
MR	multifaceted reflector	SOLED	stacked organic light-emitting diode
		SPD	spectral power distribution
NAECA	National Appliance Energy Conservation Act	SSL	solid-state lighting
NEEP	Northeast Energy Efficiency Partnerships		
NEMA	National Electrical Manufacturers Association	TCO	transparent conductive oxide
NIST	National Institute of Standards and Technology	THD	total harmonic distortion
NPRM	Notice of Proposed Rulemaking	TIM	thermal interface material
NRC	National Research Council	TIR	total internal reflection
NYSERDA	New York State Energy Research and Development Authority	TLED	tubular light-emitting diode
		TWh	terawatt-hours (10^{12} watt-hours)
		UL	Underwriters Laboratories
OLED	organic light-emitting diode	UV	ultraviolet
ORNL	Oak Ridge National Laboratory		
OSD	Office of the Secretary of Defense	VLC	visual light communication
OVPD	organic vapor phase deposition	VTE	vacuum thermal evaporation
PAR	parabolic aluminized reflector	WOLED	white organic light-emitting diode
PCAST	Presidential Council of Advisors on Science and Technology	YAG	yttrium-aluminum garnet

